

GENERAL TECHNICAL INFORMATION	
PAGE 9-2	PAGE OMMITED
PAGE 9-3	EXTERNAL APPLICATION REFERENCE
PAGE 9-4	INTERNAL APPLICATION REFERENCE
PAGE 9-5	INSERT GRADE INFORMATION
PAGE 9-6	INSERT COATING INFORMATION
PAGE 9-7	TROUBLESHOOTING INFORMATION
PAGE 9-8	GENERAL TOOLHOLDER INFORMATION

GROOVING - CATALOG SECTION 1	
PAGE 9-9	GEOMETRY AND SET-UP INFORMATION
PAGE 9-10	SPEEDS AND FEEDS

FACE GROOVING - CATALOG SECTION 2	
PAGE 9-11	GEOMETRY AND SET-UP INFORMATION
PAGE 9-12	SPEEDS AND FEEDS

BORING & TURNING - CATALOG SECTION 3	
PAGE 9-13	GEOMETRY AND SET-UP INFORMATION
PAGE 9-14	SPEEDS AND FEEDS FOR MBE, MBF AND MBG SERIES BORING BARS
PAGE 9-15	SPEEDS AND FEEDS FOR MBZ, MBA, MBB AND MBC SERIES BORING BARS AND MICROBIT® SOLID CARBIDE BORING TOOLS
PAGE 9-16	SPEEDS AND FEEDS FOR MBA, MBB AND MBC PCD AND CBN TIPPED INSERTS

THREADING - CATALOG SECTION 4	
PAGE 9-17	GEOMETRY AND SET-UP INFORMATION
PAGE 9-18	SPEEDS AND FEEDS

PARTING - CATALOG SECTION 5	
PAGE 9-19	GEOMETRY AND SET-UP INFORMATION
PAGE 9-20	SPEEDS AND FEEDS

HOURS:

OUR BUSINESS HOURS ARE **7:30AM** TO **5:00PM** EASTERN TIME.
 PROCESSING FOR SAME DAY SHIPMENT STOPS AT **3:00PM** EASTERN TIME.

LOT NUMBERS:

MOST PRODUCTS HAVE A 6 DIGIT LOT NUMBER LASER ENGRAVED ALONG WITH THE PART NUMBER.
 THIS NUMBER MAY REQUIRE 10X MAGNIFICATION TO READ.

NOTE: REGISTERED PATENTS AND TRADEMARKS LICENSED TO KAISER TOOL COMPANY, INC. ARE LOCATED ON OUR WEBSITE AT:
[HTTP://WWW.THINBIT.COM/ABOUT/TRADE_NAMES.HTML](http://www.thinbit.com/about/trade_names.html)

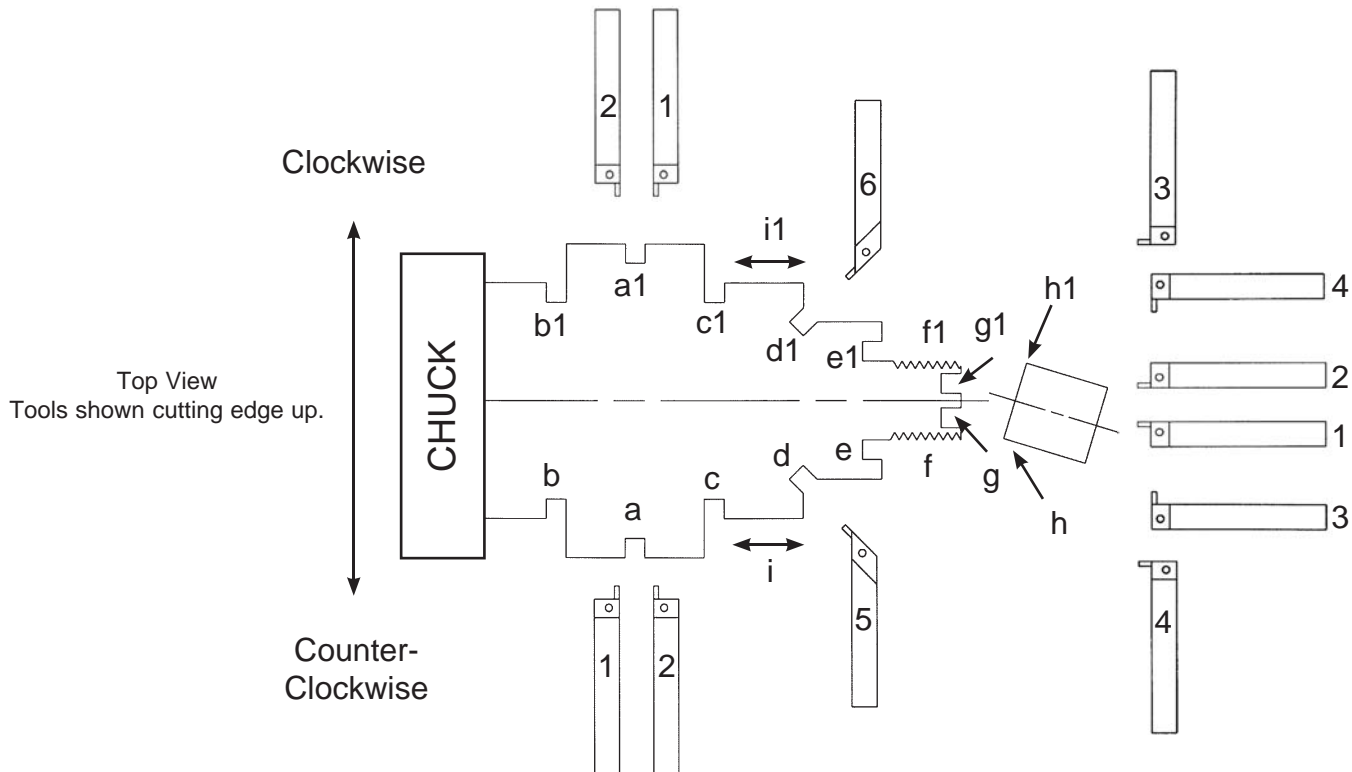

External Application Reference						
Description	Specification	Operation	Insert Orientation	Insert Page	Toolholder Compatibility	Toolholder Page
OD Groove Reference: a,a1	.004" - .150" insert widths in .001" increments; Depths of cut 2.5 to 3 times width; For grooving, turning and generating profiles; Carbide and High Speed Steel.	a	Right Hand	1-10	2,3	7-1
		a1	Left Hand	1-10	1,4	7-1
	2,3,4,5 & 6mm insert widths; Depths of cut .5" to 1".	a	---	6-1	2,3	1-11
		a1	---	6-1	1,4	1-11
OD Groove at a shoulder Reference: b,b1,c,c1	.004" - .150" insert widths in .001" increments; Depths of cut 2.5 to 3 times width; For grooving, turning and generating profiles; Carbide and High Speed Steel.	b & c1	Left Hand	1-10	1,4	7-1
		b1 & c	Right Hand	1-10	2,3	7-1
	2,3,4,5 & 6mm insert widths; Depths of cut .5" to 1".	b & c1	---	6-1	1,4	1-11
		b1 & c	---	6-1	2,3	1-11
30°/45°/60° Undercut Reference: d,d1	.004" - .150" insert widths in .001" increments; Depths of cut 2.5 to 3 times width; .300", .750", 1.250" & 3" major diameters.	d	Counter-Clockwise	2-10	5	7-11
		d1	Clockwise	8-2	6	7-11
Face Groove Reference: e,e1,g,g1	.004" - .150" insert widths in .001" increments; Depths of cut 2.5 to 3 times width; For grooving, turning and generating profiles; Carbide and High Speed Steel.	e & g	Counter-Clockwise	2-10	1,4	7-1
		e1 & g1	Clockwise	8-2	2,3	7-1
	2,3,4,5 & 6mm insert widths; Depths of cut .5" to 1".	e & g	---	6-1	1,4	2-11
		e1 & g1	---	6-1	2,3	2-11
Threading Reference: f,f1	8-56 Threads Per Inch; Carbide and High Speed Steel.	f	Right Hand	4-10	2,3	7-1
		f1	Left Hand	4-10	1,4	7-1
	Acme threading 6 Threads Per Inch and greater Carbide and High Speed Steel	f & f1	Right Hand	4-12	2,3	7-1
Parting Reference: h,h1	.025", .045", .062", .085" & .115" insert widths; Depths of cut .200" and .500"; Carbide and High Speed Steel.	h	---	5-4	2,3	7-1
		h1	---	5-4	1,4	7-1
Turning Reference: i,i1	TD and TP style inserts.	i	---	3-16,3-18	2,3	3-20
		i1	---	3-16,3-18	1,4	3-20

KAISER TOOL COMPANY, INC.

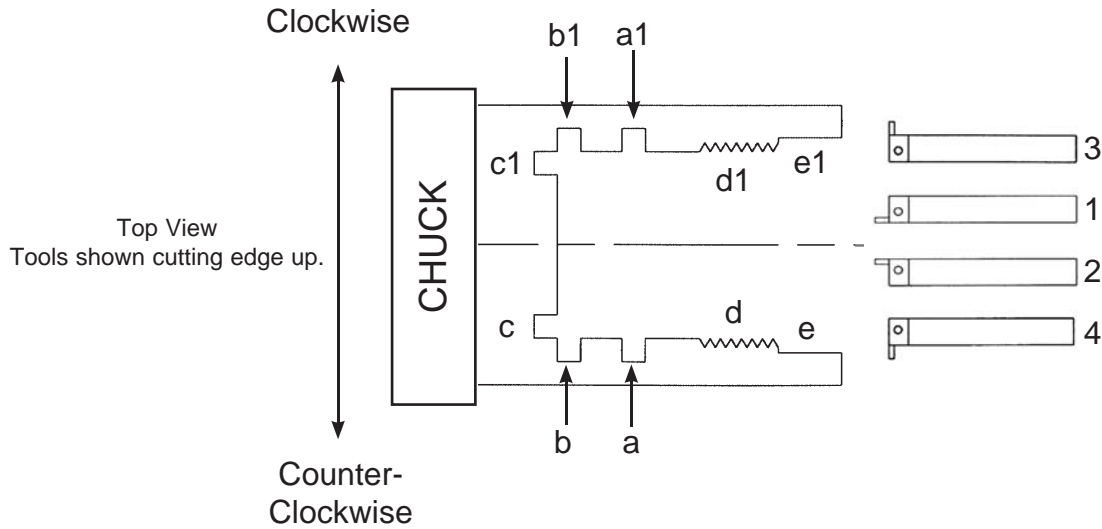

Internal Application Reference						
Description	Specification	Operation	Insert Orientation	Insert Page	Toolholder Compatibility	Toolholder Page
Groove Reference: a,a1,b,b1	For internal diameters .125" and larger; .004" - .250" insert widths in .001" increments; Depths of cut to .150"; 1/8", 3/16", 1/4", 5/16", 1/2" solid carbide shanks.	a,b	Left Hand	1-4	---	7-2
		a1 & b1	Right Hand	1-4	---	7-2
	For internal diameters .325" and larger; .004" - .125" insert widths in .001" increments; Depths of cut to .125"; For grooving, boring and generating profiles.	a & b	Left Hand	2-5	4	1-6
		a1 & b1	Right Hand	2-5	3	1-6
	For internal diameters 1" and larger; 2,3 & 4mm insert widths; Depths of cut .5".	a & b	---	6-1	4	1-8
		a1 & b1	---	6-1	3	1-8
Face Groove Reference: c,c1	For internal diameters .125" and larger; .004" - .250" insert widths in .001" increments; Depths of cut to .150"; 1/8", 3/16", 1/4", 5/16", 1/2" solid carbide shanks.	c	Right Hand	2-4	---	7-2
		c1	Left Hand	2-4	---	7-2
	For internal diameters .325" and larger; .004" - .125" insert widths in .001" increments; Depths of cut to .125"; For grooving, boring and generating profiles.	c	Right Hand	2-5	2	2-6
		c1	Left Hand	2-5	1	2-6
	For internal diameters 1.547" and larger; 2,3,4,5 & 6mm insert widths; Depths of cut .5" to 1".	c	---	6-1	2	2-8
		c1	---	6-1	1	2-8
Threading Reference: d,d1	For internal diameters .077" and larger; 4 Threads per Inch and greater; 1/8", 3/16", 1/4", 5/16", 1/2" solid carbide shanks.	d	Right Hand	4-4	---	7-2
		d1	Left Hand	4-4	---	7-2
	For internal diameters .187" and larger 6 Threads per Inch and greater 3/16", 1/4", 5/16", 3/8" solid carbide shanks.	d	Right Hand	4-6	---	7-2
		d1	Left Hand	4-6	---	7-2
	For internal diameters .325" and larger; 9 Threads per Inch and greater.	d	Left Hand	4-8	4	1-6
		d1	Right Hand	4-8	3	1-6
	For internal diameters 1.250" and larger; 8 Threads per Inch and greater; Carbide and High Speed Steel.	d	Right Hand	4-10	4	7-1
		d1	Left Hand	4-10	3	7-1
Boring Reference: e,e1	For internal diameters .073" and larger; 1/8", 3/16", 1/4", 5/16", 1/2" solid carbide shanks.	e	Right Hand	3-4	---	7-2
		e1	Left Hand	3-4	---	7-2
	For internal diameters .180" and larger; WCGT, CD, TD and TP style inserts.	e	---	3-1	4	3-1
		e1	---	3-1	3	3-1

KAISER TOOL COMPANY, INC.

Phone: 888-THINBIT (888-844-6248) or (260) 484-3620 • Fax: 888-THINFAX (888-844-6329) or (260) 482-1881
www.thinbit.com • General E-mail: thinbit@kaisertool.com • Orders: orders@thinbit.com • Quotes: quotes@thinbit.com

DURA-MAX® 2000 CARBIDE

DURA-MAX® 2000 is a versatile and tough sub-micron grain carbide. Because of its high transverse rupture strength and fine grain structure, **DURA-MAX® 2000** performs well with interrupted cuts. This grade is recommended for cutting steel, cast iron, stainless steel and applications where there are interrupted cuts.

DURA-MAX® 2000 approximates an ANSI C4/C5.

DURA-MAX® 3000 CARBIDE

DURA-MAX® 3000 is a hard and wear resistant sub-micron grain carbide. **DURA-MAX® 3000** is designed for light finish cuts. This grade is recommended for cutting steels and applications where precision finish cuts are required.

DURA-MAX® 3000 approximates an ANSI C7/C8.

DURA-MAX® 3000 inserts are only available on MINI-BORE® style inserts. See Section 3 of this catalog for further detail.

DURA-MAX® 4000 CARBIDE

DURA-MAX® 4000 is a tough, general purpose sub-micron grain carbide. **DURA-MAX® 4000** is designed for roughing. This grade is recommended for cutting steels, stainless steel, nickel based alloys and applications where there are interrupted cuts.

DURA-MAX® 4000 approximates an ANSI C5/C6.

DURA-MAX® 4000 inserts are only available on MINI-BORE® style inserts. See Section 3 of this catalog for further detail.

DURA-MAX® 5000 CARBIDE

DURA-MAX® 5000 is a hard, abrasion resistant, sub-micron grain carbide. Because of its hardness and fine grain structure, **DURA-MAX® 5000** provides excellent edge and corner retention. This grade is recommended for cutting abrasive materials, non-ferrous alloys, aluminum, plastic and applications where there are no interrupted cuts.

DURA-MAX® 5000 approximates an ANSI C2/C3.

DURA-MAX® 8000 CBN

DURA-MAX® 8000 is a **CBN** tipped insert which provides an increased production rate, improved surface finish and dimensional control when used on high-temperature alloys such as inconel, nickel base alloys and materials with a hardness of Rockwell C-35 or harder.

DURA-MAX® 8000 CBN tipped inserts are only available on MINI-BORE® style inserts. See Section 3 of this catalog for further detail.

DURA-MAX® 9000 PCD

DURA-MAX® 9000 is a **PCD** tipped insert which provides an increased production rate, improved surface finish and dimensional control when used on non-ferrous and abrasive metals such as aluminum, brass and copper.

DURA-MAX® 9000 PCD tipped inserts are only available on MINI-BORE® style inserts. See Section 3 of this catalog for further detail.

HIGH SPEED STEEL

High Speed Steel will cut most materials. It will take considerable abuse. However, high speed steel will not wear as well as carbide. We suggest the use of high speed steel for jobs of 500 cuts or less. It also works well on older machines which do not have high enough spindle speeds to take advantage of carbide.

High Speed Steel is an M42 grade.

KAISER TOOL COMPANY, INC.

<p>TiN (TITANIUM NITRIDE)</p>	<p>Excellent general purpose PVD coating for most applications. TiN offers excellent wear resistance and allows 10% - 30% increase in speeds and feeds. TiN also increases lubricity at cutting edge which reduces galling and welding. TiN is not recommended for Nickel alloys or Titanium.</p> <p>Color: Yellow/gold</p> <p>Thickness: 2-4 microns (.0001"-.0002")</p>
<p>TiCN (TITANIUM CARBONITRIDE)</p>	<p>A multi-layer, PVD coating good for cutting Aluminum, Brass, Bronze, Copper and its alloys and Cast Iron. TiCN improves tool life and allows increased speeds and feeds. Should out-perform TiN in abrasive and difficult to machine materials. TiCN is harder and more impact resistant than TiN.</p> <p>Color: Gray/bronze</p> <p>Thickness: 2-6 microns (.0001"-.0004")</p>
<p>TiAlN (TITANIUM ALUMINUM NITRIDE)</p>	<p>A high performance PVD coating which excels in cutting abrasive or difficult-to-machine materials such as Titanium, Inconel, Waspaloy, Hastelloy, High Nickel Alloys, harder varieties of Stainless Steel. Good performance with interrupted cuts, high temperatures and dry machining.</p> <p>Color: Dark gray/black</p> <p>Thickness: 2-4 microns (.0001"-.0002")</p>
<p>DIAMOND</p>	<p>Works well in cutting Aircraft Aluminum, Automotive Cast Aluminum, Copper, Brass, Graphite, Carbon, Various Plastics, Nylon, Natural Wood, Composite Woods and Kurtzite. Diamond coating is not recommended for cutting steels or other ferrous metals.</p> <p>Color: Black</p> <p>Thickness: 2-6 microns (.0001"-.0004")</p>

Note on coolants:

THINBIT[®] inserts are compatible with all coolant types. Carbide and High Speed Steel give best performance on most materials when run flooded with coolant. Carbide does not perform well in thermal shock situations. Keep insert flooded or run dry.

Note on coatings:

Part numbers may not always include coating designation.

KAISER TOOL COMPANY, INC.

It is critical for small tooling to have correct set ups. Speeds and feeds, condition of toolholder, insert and machine, centerline heights, squareness of cutting edge to machine, rigid machine to toolholder relationships are vital for proper performance in all applications. The items listed are general guides, but will not solve all problems. Please call our sales office for additional assistance.

Problem	Things to try
Grooving	
Cutting oversized; Groove walls not square	Check insert squareness; Check toolholder condition; Check insert centerline; Check machine alignment; Decrease IPR
Chatter; Poor finish	Increase speed; Reduce feed; Check toolholder condition; Check centerline; Stub toolholder and review toolholder size and machine set up for maximum rigidity; Add coating; Add top rake
Built up edge; Insert chipping	Increase feed; Increase speed; Run with coolant; Use coated insert; Check insert centerline
Burr on part	Add chamfer to insert; Turn or bore diameter after groove
Insert breaking	Check insert squareness; Check toolholder condition; Check insert centerline; Check machine condition; Decrease IPR; Review speeds and feeds; Verify insert grade
Chip control	Increase feed; Use peck cycle; Mount with cutting edge down; Flood with coolant; Add chip control to insert
Face Grooving	
Cutting oversized; Groove walls not square	Check insert squareness; Check toolholder condition; Check insert centerline; Check machine alignment; Decrease IPR
Chatter; Poor finish	Increase speed; Reduce feed; Check toolholder condition; Check centerline; Stub toolholder and review toolholder size and machine set up for maximum rigidity; Add coating; Add top rake
Built up edge; Insert chipping	Increase feed; Increase speed; Run with coolant; Use coated insert; Check insert centerline
Burr on part	Add chamfer to insert; Turn or bore diameter after groove
Insert breaking	Check insert squareness; Verify clearance diameter; Check insert centerline; Check toolholder condition; Check machine condition; Decrease IPR; Review speeds and feeds; Verify insert grade
Chip control	Increase feed; Use peck cycle; Mount with cutting edge down; Flood with coolant; Add chip control to insert
Boring/Turning	
Chatter; Poor Finish	Increase speed; Reduce feed; Check toolholder condition; Check centerline; Verify chip evacuation; Verify coolant reaching cutting edge; Stub toolholder and review toolholder size and machine set up for maximum rigidity; Add coating; Add top rake
Built up edge; Insert chipping	Increase feed; Increase speed; Increase corner radius; Run with coolant; Use coated insert; Check insert centerline
Insert breaking	Check squareness; Verify clearance diameter; Check centerline; Check toolholder condition; Check machine condition; Decrease IPR; Review speeds and feeds; Verify insert grade
Chip control	Increase feed; Mount with cutting edge down; Flood with coolant; Add chip control to insert
Threading	
Chatter; Poor finish	Increase speed; Reduce depth of cut per pass; Check toolholder condition; Check centerline; Verify chip evacuation; Verify coolant reaching cutting edge; Stub toolholder and review toolholder size and machine set up for maximum rigidity; Add coating
Built up edge; Insert chipping	Increase depth of cut per pass; Increase speed; Increase corner radius; Run with coolant; Use coated insert; Check insert centerline
Insert breaking	Check squareness; Check centerline; Check toolholder condition; Check machine condition; Decrease depth of cut per pass; Review speeds and feeds; Verify insert grade
Parting	
Insert leading; Faces not square	Check insert squareness; Check toolholder condition; Check insert centerline; Check machine alignment; Decrease IPR; Add lead angle
Chatter; Poor finish	Increase speed; Reduce feed; Check toolholder condition; Check centerline; Stub toolholder and review toolholder size and machine set up for maximum rigidity; Add coating; Add top rake
Built up edge; Insert chipping	Increase feed; Increase speed; Run with coolant; Use coated insert; Check insert centerline
Burr on part	Chamfer before parting; Add lead angle to drop side of insert
Insert breaking	Check insert squareness; Check toolholder condition; Check insert centerline; Check machine condition; Decrease IPR; Review speeds and feeds; Verify insert grade
Chip control	Increase feed; Use peck cycle; Mount with cutting edge down; Flood with coolant; Add chip control to insert

KAISER TOOL COMPANY, INC.

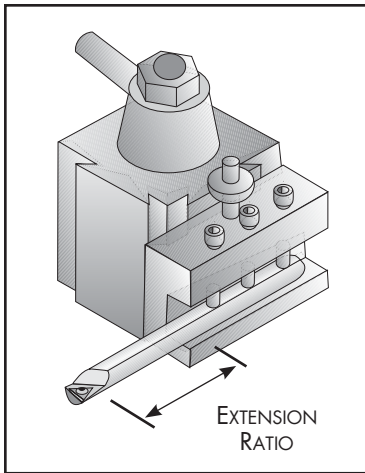

Extension Ratios					
Bar Diameter	Steel 4 x ø	Heavy Metal 6 x ø	Carbide 8 x ø	Shank Height	Steel
.156"	.625"	.937"	1.250"	.312"	1.250"
.187"	.750"	1.125"	1.500"	.375"	1.500"
.250"	1.000"	1.500"	2.000"	.500"	2.000"
.312"	1.250"	1.875"	2.500"	.625"	2.500"
.375"	1.500"	2.250"	3.000"	.750"	2.500"
.500"	2.000"	3.000"	4.000"	1.000"	2.500"
.625"	2.500"	3.750"	5.000"	1.250"	2.500"
.750"	3.000"				
1.000"	4.000"				

Extending a toolholder beyond these recommendations can cause excessive deflection which will result in poor surface finish and reduced insert life. These recommendations may need to be reduced if cutting materials with low machinability, taking heavy cuts or using the tooling in non-rigid machine set-ups.

Toolholder Notes:

- To avoid burrs on your shanks, use only dog point screws. The use of cup point screws promotes burrs on the shanks and can result in problems removing or re-installing bars.
- Complete toolholders may be an assembly of several components each having an individual part number.
- Heavy Metal is a high density Tungsten based alloy that is very tough, stiff and vibration resistant.

INTERNAL TOOL & FACE GROOVING CUTTING HEIGHTS

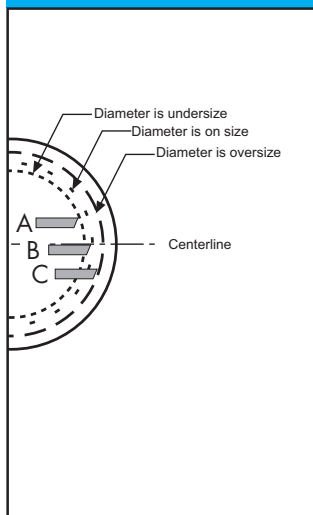

- Normal cutting forces cause tool deflection, therefore internal tools are manufactured to cut .002" to .010" above centerline.
- Setting tool above 'A' will cause diameter to be under desired size.
- Setting tool to cut at 'A' will cause insert to deflect to 'B' and cut desired diameter.
- Setting tool below 'A' will cause insert to deflect to 'C' and cause diameter to be oversized.
- Keep in mind if tools are mounted cutting edge toward floor, above center is toward floor.

EXTERNAL TOOL CUTTING HEIGHTS

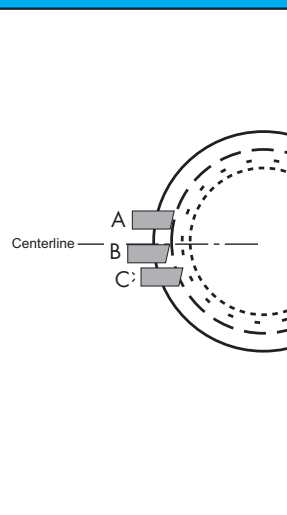

- External tools are manufactured to cut on center to .005" below centerline.
- Setting tool to cut at 'A' can cause heel of insert to rub or cause failure.
- Setting tool to cut at 'B' will cause insert to deflect slightly and cut at 'C'.
- Setting tool below 'C' can cause insert to grab or fail.
- Keep in mind if tools are mounted cutting edge toward floor, below center is toward ceiling.

DEEPCROOVE® Head and Shank Compatibility Chart

Shank	Package	Page	Head	Clamp	Shank	Package	Page	Head	Clamp	Shank	Package	Page	Head	Clamp
DGS__XL	C	2-16	DGH4	DGC2	DGS__XR	B	2-16	DGH3	DGC1	DGS__ZR	N	2-8	DGH6	DGC6
	E	1-14	DGH2	DGC2		F	1-14	DGH1	DGC1		O	7-11	DGH3	DGC1
	S	7-14	DGH5	DGC5		T	7-14	DGH6	DGC6		Q	7-11	DGH1	DGC1
DGS__YR	D	2-16	DGH4	DGC2	DGS__YL	A	2-16	DGH3	DGC1	DGS__ZL	M	2-8	DGH5	DGC5
	G	1-14	DGH2	DGC2		H	1-14	DGH1	DGC1		P	7-11	DGH4	DGC2
	U	7-14	DGH5	DGC5		V	7-14	DGH6	DGC6		R	7-11	DGH2	DGC2

KAISER TOOL COMPANY, INC.

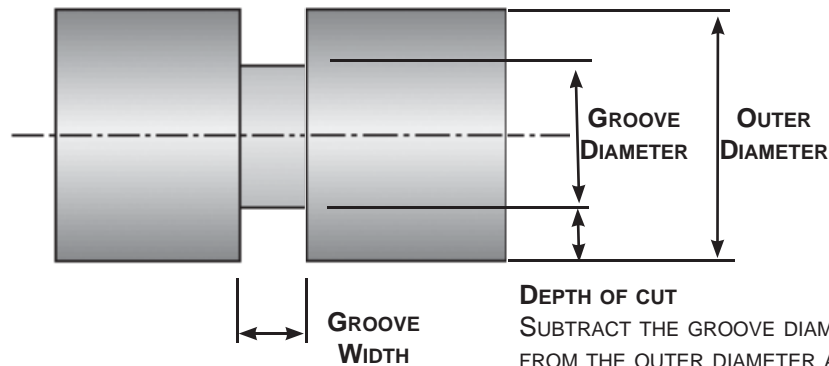

SUBTRACT THE GROOVE DIAMETER FROM THE OUTER DIAMETER AND DIVIDE BY 2.

Example: 1" outer diameter with .75" groove diameter.

$$\frac{1" - .75"}{2} = .125" \text{ depth of cut}$$

External Grooving Applications

Decrease surface speed (SFM)

Increase feed (IPR)

Set tool on center to .005" below center. Keep smaller inserts closer to center.

Modify Parameter

Insert width: .004" .020" .040" .060" .080" .100" .120" .140" .160" .180" .200" .220" .250"

Modify Parameter

Internal Grooving Applications

Decrease surface speed (SFM)

Increase feed (IPR)

Set tool .002" to .010" above center. Keep smaller inserts closer to center.

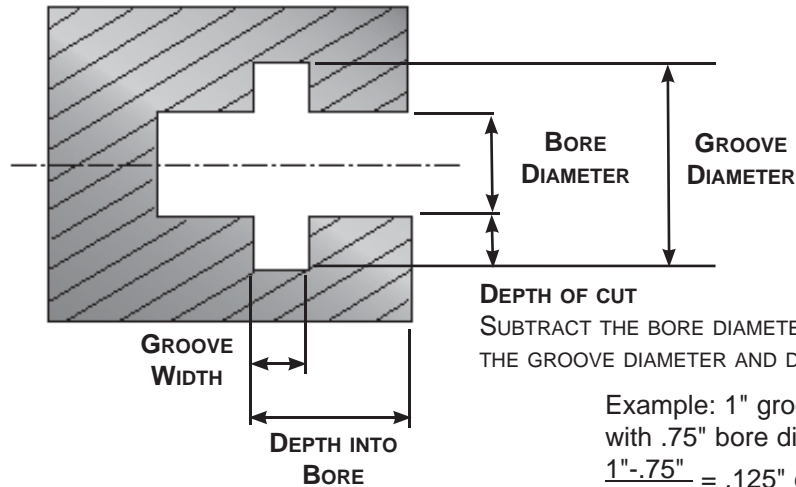

SUBTRACT THE BORE DIAMETER FROM THE GROOVE DIAMETER AND DIVIDE BY 2.

Example: 1" groove diameter with .75" bore diameter.

$$\frac{1" - .75"}{2} = .125" \text{ depth of cut}$$

Insert begins with:
LGT, MGTI, GT

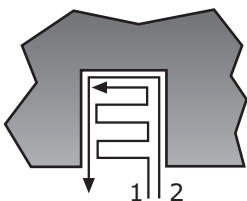

Insert begins with:
DGI, DGMI

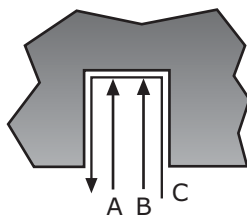

Cutting Paths

Use these diagrams for expanding the size of grooves.

Note: Side load on path 1 should be 10% to 30% of depth of cut on insert.

KAISER TOOL COMPANY, INC.

Speeds & Feeds - Grooving

Material To Be Cut		Carbide			High Speed Steel	
		Carbide Grade	Speed (SFM)	Feed (IPR)	Speed (SFM)	Feed (IPR)
Aluminum	2021-6061	DURA-MAX® 5000	1000	.002	500	.002
Brass		DURA-MAX® 5000	250	.001	75	.001
Bronze		DURA-MAX® 5000	250	.001	70	.001
Cast Iron	Gray	DURA-MAX® 5000	120-345	.0015-.004	35-125	.0015-.004
	Ductile	DURA-MAX® 2000	70-345	.001-.004	15-125	.001-.004
	Malleable	DURA-MAX® 2000	75-525	.0015-.003	35-170	.0015-.003
Copper	101-757	DURA-MAX® 5000	150-170	.002	85-90	.002
	834-978	DURA-MAX® 5000	600	.003	340	.003
Magnesium	AZ, AM, EZ, ZE, HK Types	DURA-MAX® 5000	1000	.002	500	.002
Nickel	Nickel 200-230	DURA-MAX® 5000	225	.002	85	.002
	Monel	DURA-MAX® 5000	150	.001-.0015	15-60	.001-.0015
	Inconel, Waspaloy	DURA-MAX® 5000	45	.002	15	.002
	Hastelloy	DURA-MAX® 5000	75-95	.002	10-15	.002
Plastic	Teflon (TFE, CTFE)	DURA-MAX® 5000	400	.002	250	.002
	Nylon	DURA-MAX® 5000	350-600	.002-.003	350	.002-.003
	Phenolic	DURA-MAX® 5000	600	.003	350	.003
	Glass Filled	DURA-MAX® 5000	250	.002	NA	NA
Stainless Steels	201-385	DURA-MAX® 5000	225-275	.001-.0015	65-85	.001-.0015
	405-446	DURA-MAX® 2000	300	.0011	90	.0011
	14-4, 15-5, 16-6, 17-4 PH	DURA-MAX® 2000	110-205	.0006-.0012	30-60	.0006-.0012
Steel	1005-1029	DURA-MAX® 2000	255-450	.001-.002	80-140	.001-.002
	1030-1055	DURA-MAX® 2000	115-370	.0009-.0015	35-115	.0009-.0015
	1060-1095	DURA-MAX® 2000	95-255	.0007-.001	30-80	.0007-.001
	10L45-10L50	DURA-MAX® 2000	130-450	.0009-.0015	40-140	.0009-.0015
	12L13-12L15	DURA-MAX® 2000	550-600	.003-.0035	225-280	.003-.0035
	41L30-41L50	DURA-MAX® 2000	65-350	.0007-.0015	20-110	.0007-.0015
	4140-4150	DURA-MAX® 2000	65-370	.0007-.0015	20-115	.0007-.0015
	4140 (35 HRC)	DURA-MAX® 2000	200	.001	70	.001
	8617-8622	DURA-MAX® 2000	125-390	.001-.0016	40-120	.001-.0016
	M1-M6	DURA-MAX® 2000	190	.0013	60	.0013
	H10-H19	DURA-MAX® 2000	65-255	.0007-.0011	20-80	.007-.0011
	D2-D7	DURA-MAX® 2000	150-205	.001	45-60	.001
	A2-A9, 01-07	DURA-MAX® 2000	150-205	.001	45-60	.001
	W1, W2	DURA-MAX® 2000	375	.0015	110	.0015
	M-50, 52100	DURA-MAX® 2000	65-275	.0007-.0015	20-85	.0007-.0015
Titanium	Ti-6Al-6V	DURA-MAX® 5000	95	.001	45	.001

THESE SPEEDS AND FEEDS ARE GIVEN AS A STARTING POINT ONLY AND MAY BE ADJUSTED UP OR DOWN DEPENDING ON CONDITIONS. ANY TIME THERE IS AN INTERRUPTED CUT IN YOUR OPERATION, **DURA-MAX® 2000** CARBIDE IS RECOMMENDED.

FORMULA FOR CONVERSION FROM SFM TO RPM

SFM = SURFACE FEET PER MINUTE RPM = REVOLUTIONS PER MINUTE IPR = INCHES PER REVOLUTION DIAMETER = CUTTING DIAMETER $\pi = 3.14$

$$RPM = \frac{SFM \times 12}{(\pi) \times DIAMETER}$$

KAISER TOOL COMPANY, INC.

Phone: 888-THINBIT (888-844-6248) or (260) 484-3620 • Fax: 888-THINFAX (888-844-6329) or (260) 482-1881
 www.thinbit.com • General E-mail: thinbit@kaisertool.com • Orders: orders@thinbit.com • Quotes: quotes@thinbit.com

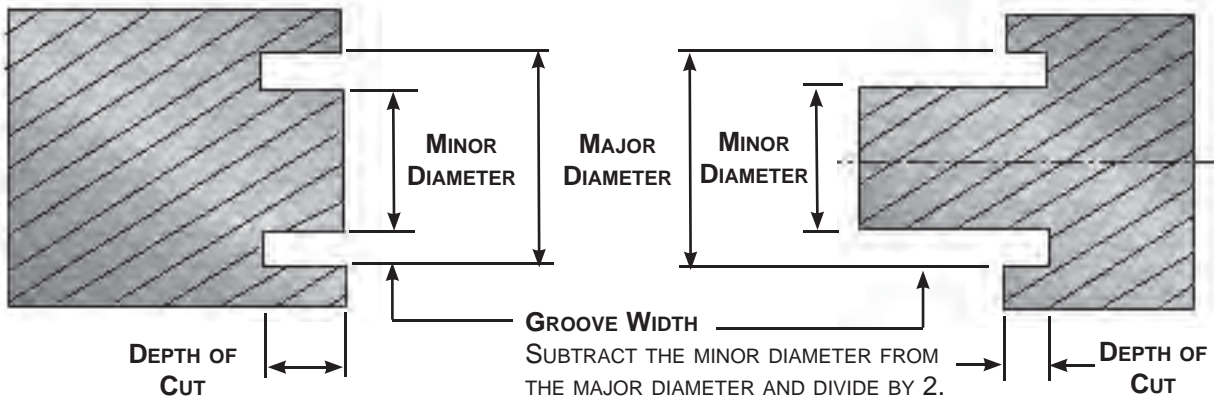

Example: 1" major diameter with .75" minor diameter.
 $\frac{1" - .75"}{2} = .125"$ Groove Width

Setup Guide

External Face Grooving Applications

Decrease surface speed (SFM)
Increase feed (IPR)

Set tool on .002" to .010" above center. Keep smaller inserts closer to center.

	Modify Parameter	
Insert width:	.004" .020" .040" .060" .080" .100" .120" .140" .160" .180" .200" .220" .250"	Modify Parameter

Internal Face Grooving Applications

Decrease surface speed (SFM)
Increase feed (IPR)

Set tool .002" to .010" above center. Keep smaller inserts closer to center.

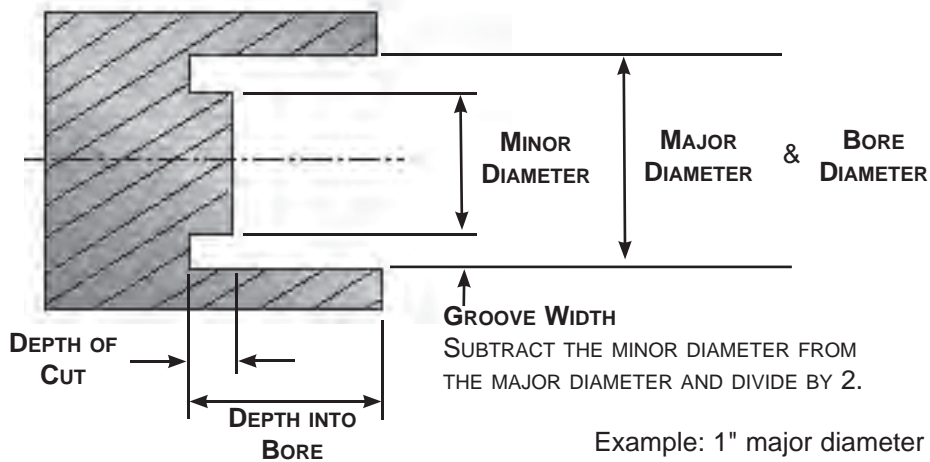

Example: 1" major diameter with .75" minor diameter.
 $\frac{1" - .75"}{2} = .125"$ Groove Width

Insert begins with:
LGT, MGT1, FT

Insert begins with:
DGI, DGMI

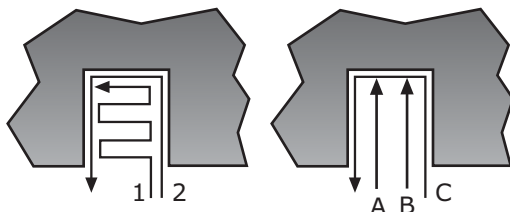

Cutting Paths

Use these diagrams for expanding the size of grooves.

Note: Side load on path 1 should be 10% to 30% of depth of cut on insert.

KAISER TOOL COMPANY, INC.

Speeds & Feeds - Face Grooving

Material To Be Cut		Carbide			High Speed Steel	
		Carbide Grade	Speed (SFM)	Feed (IPR)	Speed (SFM)	Feed (IPR)
Aluminum	2021-6061	DURA-MAX® 5000	1000	.002-.003	525	.002-.003
Brass		DURA-MAX® 5000	250	.001	75	.001
Bronze		DURA-MAX® 5000	250	.001	70	.001
Cast Iron	Gray	DURA-MAX® 5000	300-500	.0017-.0027	35-115	.0017-.0027
	Ductile	DURA-MAX® 2000	250-425	.0013-.0027	30-75	.0013-.0027
	Malleable	DURA-MAX® 2000	300-600	.0013-.0027	35-120	.0013-.0027
Copper	101-757	DURA-MAX® 5000	450-550	.002	80-90	.0013-.0017
	834-978	DURA-MAX® 5000	600	.003	325	.0017
Magnesium	AZ, AM, EZ, ZE, HK Types	DURA-MAX® 5000	1000	.001-.002	650	.001-.002
Nickel	Nickel 200-230	DURA-MAX® 5000	225	.002	80	.001
	Monel	DURA-MAX® 5000	45-150	.001-.002	40-55	.001-.002
	Inconel, Waspaloy	DURA-MAX® 5000	75-100	.0013	10	.001
	Hastelloy	DURA-MAX® 5000	100-125	.0013-.0017	10-15	.001-.0015
Plastic	Teflon (TFE, CTFE)	DURA-MAX® 5000	400	.003	250	.003
	Nylon	DURA-MAX® 5000	350-600	.002-.003	350	.002-.003
	Phenolic	DURA-MAX® 5000	600	.003	350	.003
	Glass Filled	DURA-MAX® 5000	250	.002	N/A	N/A
Stainless Steels	201-385	DURA-MAX® 5000	225-275	.0013-.002	60-65	.001
	405-446	DURA-MAX® 2000	275	.002	90	.001
	14-4, 15-5, 16-6, 17-4 PH	DURA-MAX® 2000	125-150	.0013-.002	40-50	.001
Steel	1005-1029	DURA-MAX® 2000	400-500	.002-.003	75-110	.002-.003
	1030-1055	DURA-MAX® 2000	325-450	.0013-.0027	30-85	.0013-.0027
	1060-1095	DURA-MAX® 2000	325-400	.0016-.0027	30-70	.0016-.0027
	10L45-10L50	DURA-MAX® 2000	300-600	.0017-.0027	35-130	.0017-.0027
	12L13-12L15	DURA-MAX® 2000	500-600	.002-.003	105-130	.002-.003
	41L30-41L50	DURA-MAX® 2000	325-500	.0013-.0027	30-105	.0013-.0027
	4140-4150	DURA-MAX® 2000	325-450	.0013-.0027	30-95	.0013-.0027
	4140 (35 HRC)	DURA-MAX® 2000	350	.0013	45	.0013
	8617-8622	DURA-MAX® 2000	250-475	.001-.0023	30-90	.001-.0023
	M1-M6	DURA-MAX® 2000	350	.002	50	.001
	H10-H19	DURA-MAX® 2000	300-425	.001-.002	35-75	.001-.002
	D2-D7	DURA-MAX® 2000	300-375	.002	35-60	.0015-.002
	A2-A9, 01-07	DURA-MAX® 2000	300-375	.002	35-60	.0015-.002
	W1, W2	DURA-MAX® 2000	425	.002	75	.002
	M-50, 52100	DURA-MAX® 2000	350	.002	55	.002
Titanium	Ti-6Al-6V	DURA-MAX® 5000	95	.001	40	.002

THESE SPEEDS AND FEEDS ARE GIVEN AS A STARTING POINT ONLY AND MAY BE ADJUSTED UP OR DOWN DEPENDING ON CONDITIONS. ANY TIME THERE IS AN INTERRUPTED CUT IN YOUR OPERATION, **DURA-MAX® 2000** CARBIDE IS RECOMMENDED.

FORMULA FOR CONVERSION FROM SFM TO RPM

SFM = SURFACE FEET PER MINUTE RPM = REVOLUTIONS PER MINUTE

IPR = INCHES PER REVOLUTION

DIAMETER = CUTTING DIAMETER

$\pi = 3.14$

$$RPM = \frac{SFM \times 12}{(\pi) \times DIAMETER}$$

KAISER TOOL COMPANY, INC.

Phone: 888-THINBIT (888-844-6248) or (260) 484-3620 • Fax: 888-THINFAX (888-844-6329) or (260) 482-1881
 www.thinbit.com • General E-mail: thinbit@kaisertool.com • Orders: orders@thinbit.com • Quotes: quotes@thinbit.com

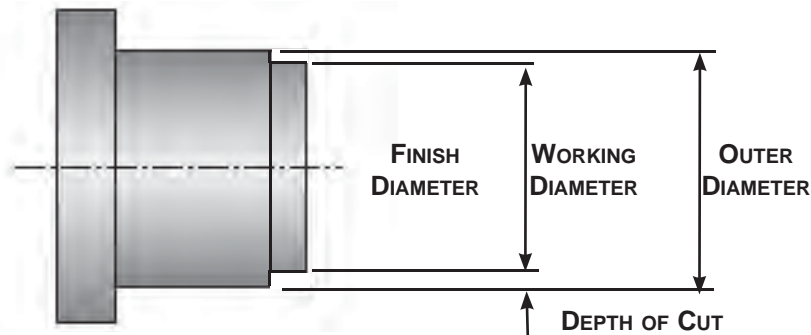

DEPTH OF CUT
SUBTRACT THE WORKING DIAMETER FROM THE OUTER DIAMETER AND DIVIDE BY 2.

Example: 1" outer diameter with .976" working diameter.

$$\frac{1" - .976"}{2} = .012" \text{ depth of cut}$$

Turning Applications

Decrease surface speed (SFM)
Increase feed (IPR)
Increase depth of cut

Set tool on center to .005" below center. Keep smaller inserts closer to center.

Modify Parameter →

MBZ MBA MBE MBB MBF MBC MBG

Tool starts with:

BT21 BT31 BT41 BT51 BT61 BT81

Modify Parameter →

Boring Applications

Decrease surface speed (SFM)
Increase feed (IPR)
Increase depth of cut

Set tool .002" to .010" above center. Keep smaller tools closer to center.

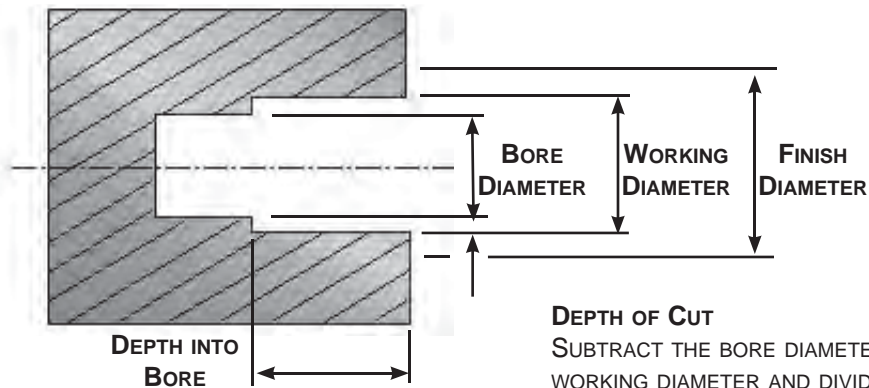

DEPTH OF CUT
SUBTRACT THE BORE DIAMETER FROM THE WORKING DIAMETER AND DIVIDE BY 2.

Example: 1" working diameter with .976" bore diameter.

$$\frac{1" - .976"}{2} = .012" \text{ depth of cut}$$

Cutting Paths:

- Internal tools designed for feeding into bore.
- External tools designed for feeding toward chuck.

NUMBER OF PASSES

SUBTRACT THE FINISH DIAMETER FROM THE OUTER DIAMETER AND DIVIDE BY 2 TIMES THE DEPTH OF CUT PER PASS.

Example: 1" outer diameter with .875" finish diameter and .012" per pass.

$$\frac{1" - .875"}{2 \times .012"} = 5.2 \text{ or } 6 \text{ passes}$$

Note: Leave 30% - 50% of depth of cut for finish pass.

KAISER TOOL COMPANY, INC.

Speeds & Feeds - MBE, MBF & MBG Style Inserts

Material To Be Cut		Carbide Grade	Speed (SFM)	Feed (IPR)	Depth of Cut		
					MBE	MBF	MBG
Aluminum	2021-6061	DURA-MAX[®] 5000	450-1000	.005-.012	.012	.014	.016
Brass		DURA-MAX[®] 5000	300-400	.002-.005	.010	.010	.012
Bronze		DURA-MAX[®] 5000	300-400	.002-.005	.009	.010	.012
Cast Iron	Gray	DURA-MAX[®] 5000	200-300	.005-.010	.010	.012	.015
	Ductile	DURA-MAX[®] 4000	200-300	.005-.010	.010	.012	.015
	Malleable	DURA-MAX[®] 4000	100-300	.005-.010	.010	.012	.015
Copper	101-757	DURA-MAX[®] 4000	400-750	.003-.005	.012	.014	.016
	834-978	DURA-MAX[®] 5000	300-700	.003-.005	.012	.014	.016
Magnesium	AZ, AM, EZ, ZE, HK Types	DURA-MAX[®] 5000	700-1300	.005-.012	.012	.014	.016
Nickel	Nickel 200-230	DURA-MAX[®] 4000	100-250	.002-.005	.008	.008	.008
	Monel	DURA-MAX[®] 4000	80-120	.0005-.001	.008	.008	.008
	Inconel, Waspaloy	DURA-MAX[®] 4000	70-95	.001-.003	.008	.008	.008
	Hastelloy	DURA-MAX[®] 4000	50-80	.001-.003	.008	.008	.008
Plastic	Teflon (TFE, CTFE)	DURA-MAX[®] 5000	500-850	.004-.008	.010	.012	.015
	Nylon	DURA-MAX[®] 5000	700-1000	.002-.005	.010	.012	.015
	Phenolic	DURA-MAX[®] 5000	700-1000	.005	.010	.012	.015
	Glass Filled	DURA-MAX[®] 5000	700-1000	.005	.008	.012	.015
Stainless Steels	201-385	DURA-MAX[®] 4000	100-225	.002-.004	.009	.010	.012
	405-446	DURA-MAX[®] 4000	100-225	.002-.004	.008	.009	.010
	14-4, 15-5, 16-6, 17-4 PH	DURA-MAX[®] 4000	300-400	.002-.004	.008	.009	.010
Steel	1005-1029	DURA-MAX[®] 4000	100-250	.003-.007	.010	.012	.015
	1030-1055	DURA-MAX[®] 4000	100-250	.003-.007	.010	.012	.015
	1060-1095	DURA-MAX[®] 4000	100-350	.003-.007	.010	.012	.015
	10L45-10L50	DURA-MAX[®] 4000	250-450	.006-.008	.010	.012	.015
	12L13-12L15	DURA-MAX[®] 4000	250-450	.004-.006	.010	.012	.015
	41L30-41L50	DURA-MAX[®] 4000	150-350	.003-.007	.010	.012	.015
	4140-4150	DURA-MAX[®] 4000	100-350	.003-.007	.010	.012	.015
	4140 (35 HRc)	DURA-MAX[®] 4000	90-125	.003-.007	.008	.008	.010
	8617-8622	DURA-MAX[®] 4000	100-200	.004-.008	.010	.012	.015
	M1-M6	DURA-MAX[®] 4000	100-200	.004-.008	.008	.010	.012
	H10-H19	DURA-MAX[®] 4000	100-200	.004-.008	.008	.010	.012
	D2-D7	DURA-MAX[®] 4000	100-200	.004-.008	.008	.010	.012
	A2-A9, 01-07	DURA-MAX[®] 4000	100-200	.004-.008	.008	.010	.012
	W1, W2	DURA-MAX[®] 4000	100-200	.004-.008	.008	.010	.012
	M-50, 52100	DURA-MAX[®] 4000	200-300	.005-.010	.010	.012	.015
Titanium	Ti-6Al-6V	DURA-MAX[®] 5000	90-250	.001-.003	.008	.009	.010

THESE SPEEDS AND FEEDS ARE GIVEN AS A STARTING POINT ONLY AND MAY BE ADJUSTED UP OR DOWN DEPENDING ON CONDITIONS. ANY TIME THERE IS AN INTERRUPTED CUT IN YOUR OPERATION, **DURA-MAX[®] 4000** CARBIDE IS RECOMMENDED.

FORMULA FOR CONVERSION FROM SFM TO RPM

SFM = SURFACE FEET PER MINUTE RPM = REVOLUTIONS PER MINUTE IPR = INCHES PER REVOLUTION DIAMETER = CUTTING DIAMETER $\pi = 3.14$

$$\text{RPM} = \frac{\text{SFM} \times 12}{(\pi) \times \text{DIAMETER}}$$

KAISER TOOL COMPANY, INC.

Phone: 888-THINBIT (888-844-6248) or (260) 484-3620 • Fax: 888-THINFAX (888-844-6329) or (260) 482-1881
 www.thinbit.com • General E-mail: thinbit@kaisertool.com • Orders: orders@thinbit.com • Quotes: quotes@thinbit.com

Speeds & Feeds - MBZ, MBA, MBB, MBC Style Inserts & MICROBIT® Solid Carbide Tools

Material To Be Cut		Carbide Grade			Depth of Cut		
		MBA, MBB, MBC, MBZ	Speed (SFM)	Feed (IPR)	MBA, MBZ, BT2, BT3	MBB, BT4, BT5	MBC, BT6, BT8
Aluminum	2021-6061	DURA-MAX® 5000	700-1400	.005-.012	.008	.008	.016
Brass		DURA-MAX® 5000	350-400	.001-.003	.006	.006	.012
Bronze		DURA-MAX® 5000	300-400	.001-.002	.006	.006	.012
Cast Iron	Gray	DURA-MAX® 5000	250-350	.004-.010	.007	.007	.015
	Ductile	DURA-MAX® 5000	250-350	.004-.010	.007	.007	.015
	Malleable	DURA-MAX® 5000	250-350	.004-.010	.007	.007	.015
Copper	101-757	DURA-MAX® 5000	600-800	.003-.005	.008	.008	.016
	834-978	DURA-MAX® 5000	600-800	.003-.005	.008	.008	.016
Magnesium	AZ, AM, EZ, ZE, HK Types	DURA-MAX® 5000	750-1500	.005-.012	.008	.008	.016
Nickel	Nickel 200-230	DURA-MAX® 5000	100-250	.002-.005	.004	.004	.008
	Monel	DURA-MAX® 5000	80-120	.001-.003	.004	.004	.008
	Inconel, Waspaloy	DURA-MAX® 5000	80-120	.001-.003	.004	.004	.008
	Hastelloy	DURA-MAX® 5000	80-120	.001-.003	.004	.004	.008
Plastic	Teflon (TFE, CTFE)	DURA-MAX® 5000	500-600	.003-.006	.007	.007	.015
	Nylon	DURA-MAX® 5000	700-800	.001-.003	.007	.007	.015
	Phenolic	DURA-MAX® 5000	700-800	.001-.003	.007	.007	.015
	Glass Filled	DURA-MAX® 5000	700-800	.001-.003	.005	.005	.015
Stainless Steels	201-385	DURA-MAX® 5000	100-250	.0015-.004	.005	.005	.010
	405-446	DURA-MAX® 5000	100-250	.0015-.004	.005	.005	.010
	14-4, 15-5, 16-6, 17-4 PH	DURA-MAX® 5000	300-400	.002-.004	.005	.005	.010
Steel	1005-1029	DURA-MAX® 3000/4000	100-300	.003-.007	.007	.007	.015
	1030-1055	DURA-MAX® 3000/4000	100-300	.003-.007	.007	.007	.015
	1060-1095	DURA-MAX® 3000/4000	150-400	.003-.005	.007	.007	.015
	10L45-10L50	DURA-MAX® 3000/4000	300-500	.004-.006	.007	.007	.015
	12L13-12L15	DURA-MAX® 3000/4000	300-500	.003-.005	.007	.007	.015
	41L30-41L50	DURA-MAX® 3000/4000	200-400	.003-.005	.007	.007	.015
	4140-4150	DURA-MAX® 3000/4000	150-400	.003-.005	.007	.007	.015
	4140 (35 HRc)	DURA-MAX® 3000/4000	90-125	.001-.004	.004	.004	.008
	8617-8622	DURA-MAX® 3000/4000	100-300	.002-.004	.007	.007	.015
	M1-M6	DURA-MAX® 3000/4000	150-250	.003-.008	.006	.006	.012
	H10-H19	DURA-MAX® 3000/4000	150-250	.003-.007	.006	.006	.012
	D2-D7	DURA-MAX® 3000/4000	150-250	.004-.010	.006	.006	.012
	A2-A9, 01-07	DURA-MAX® 3000/4000	150-250	.003-.008	.006	.006	.012
	W1, W2	DURA-MAX® 3000/4000	150-250	.003-.008	.006	.006	.012
	M-50, 52100	DURA-MAX® 3000/4000	300-400	.004-.010	.007	.007	.015
Titanium	Ti-6Al-6V	DURA-MAX® 5000	90-250	.001-.003	.005	.005	.010

THESE SPEEDS AND FEEDS ARE GIVEN AS A STARTING POINT ONLY AND MAY BE ADJUSTED UP OR DOWN DEPENDING ON CONDITIONS. ANY TIME THERE IS AN INTERRUPTED CUT IN YOUR OPERATION, **DURA-MAX® 3000/4000** CARBIDE IS RECOMMENDED.

FORMULA FOR CONVERSION FROM SFM TO RPM

SFM = SURFACE FEET PER MINUTE RPM = REVOLUTIONS PER MINUTE IPR = INCHES PER REVOLUTION DIAMETER = CUTTING DIAMETER π = 3.14

$$RPM = \frac{SFM \times 12}{(P) \times DIAMETER}$$

KAISER TOOL COMPANY, INC.

Phone: 888-THINBIT (888-844-6248) or (260) 484-3620 • Fax: 888-THINFAX (888-844-6329) or (260) 482-1881
 www.thinbit.com • General E-mail: thinbit@kaisertool.com • Orders: orders@thinbit.com • Quotes: quotes@thinbit.com

Speeds & Feeds - DURA-MAX® 9000 (PCD Tipped) Insert					
Material To Be Cut	Speed (SFM)	Feed (IPR)	Depth of Cut		
			MBA	MBB	MBC
Aluminum (High Silicon)	1000-2000	.003-.010	.001-.007	.002-.008	.003-.012
Bronze, Brass	800-1500	.003-.010	.001-.007	.002-.008	.003-.012
Copper Alloys	800-1200	.003-.010	.001-.007	.002-.008	.003-.012
Fiberglass	500-900	.001-.005	.001-.007	.002-.008	.003-.012
Green Carbide	500 -1400	.001-.004	.001-.007	.002-.008	.003-.012
Monel	1000-2000	.003-.010	.001-.007	.002-.008	.003-.012
Phenolic	500-900	.001-.005	.001-.007	.002-.008	.003-.012
Plastics	500-900	.001-.004	.001-.007	.002-.008	.003-.012

THESE SPEEDS AND FEEDS ARE GIVEN AS A STARTING POINT ONLY AND MAY BE ADJUSTED UP OR DOWN DEPENDING ON CONDITIONS. ANY TIME THERE IS AN INTERRUPTED CUT IN YOUR OPERATION, **DURA-MAX® 3000 & 4000** CARBIDES ARE RECOMMENDED.

Speeds & Feeds - DURA-MAX® 8000 (CBN Tipped) Insert					
Material To Be Cut	Speed (SFM)	Feed (IPR)	Depth of Cut		
			MBA	MBB	MBC
52100 (58-62 HRC)	300-500	.003-.007	.001-.007	.002-.008	.003-.012
Hardened Alloy Steel	200 -400	.003-.007	.001-.007	.002-.008	.003-.012
Hardened High Carbon Steel	300-500	.003-.007	.001-.007	.002-.008	.003-.012
Hardened Tool Steel	150-300	.002-.005	.001-.007	.002-.008	.003-.012
Ni-Hard Cast Iron	100-300	.007-.015	.001-.007	.002-.008	.003-.012
Pearlitic Gray Cast Iron	800-1800	.007-.015	.001-.007	.002-.008	.003-.012
Powdered Metal	350-500	.003-.007	.001-.007	.002-.008	.003-.012
Stellite	100-200	.002-.004	.001-.007	.002-.008	.003-.012
Super Alloys	400-900	.003-.007	.001-.007	.002-.008	.003-.012
Thermal Spray Co Based	200-600	.002-.005	.001-.007	.002-.008	.003-.012
Thermal Spray Ni Based	150-450	.002-.007	.001-.007	.002-.008	.003-.012

FORMULA FOR CONVERSION FROM SFM TO RPM

SFM = SURFACE FEET PER MINUTE
RPM = REVOLUTIONS PER MINUTE
IPR = INCHES PER REVOLUTION
DIAMETER = CUTTING DIAMETER
 $\pi = 3.14$

$$RPM = \frac{SFM \times 12}{(\pi) \times DIAMETER}$$

ANSI STANDARD INSERT IDENTIFICATION SYSTEM

References to "insert type" in this catalog are based upon the ANSI B212.4-1995 system. The two letter codes refer to shape and relief angle. The use of four letter codes adds the tolerances and type (or configuration) to the first two letters. Following are the codes used for our inserts:

SHAPE

C	Diamond (80°)
T	Triangle
W	Trigon

RELIEF ANGLE

C	17°
P	11°
D	15°

TOLERANCES

	Insert I.C.	Thickness
A	+/- .0002"	+/- .001
C	+/- .0005"	+/- .001
G	+/- .001"	+/- .002

TYPE (CONFIGURATION)

B	With Hole & Countersink
D	Smaller than .250" I.C. With Hole
H	Hole, Countersink & Molded Chipbreaker
G	Hole, Countersink & Ground Chipbreaker
T	Hole, Countersink & Ground Chipbreaker One Side

BORING

KAISER TOOL COMPANY, INC.

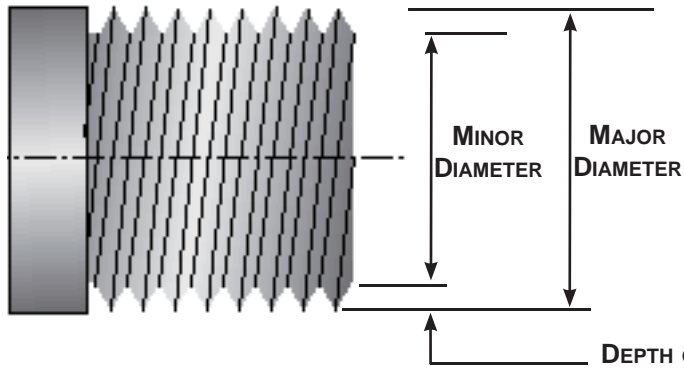

DEPTH OF THREAD

SUBTRACT THE MINOR DIAMETER FROM THE MAJOR DIAMETER AND DIVIDE BY 2.

Example: 1" major diameter with .754" minor diameter.

$$\frac{1" - .754"}{2} = .123" \text{ depth of thread}$$

External Threading Applications

Decrease surface speed (SFM)

Increase depth of cut per pass

Set tool on center to .005" below center. Keep smaller inserts closer to center.

————— Modify Parameter —————>

Tool starts with: MGTT STT LTT LGTT LGAT
 TT21 TT20 TT31 TT30 TT41 TT40 TT51 TT50 TT61 TT60 TT81 TT80
 AT31 AT41 AT51 AT61

————— Modify Parameter —————>

Internal Threading Applications

Decrease surface speed (SFM)

Decrease depth of cut per pass

Set tool .002" to .010" above center. Keep smaller tools closer to center.

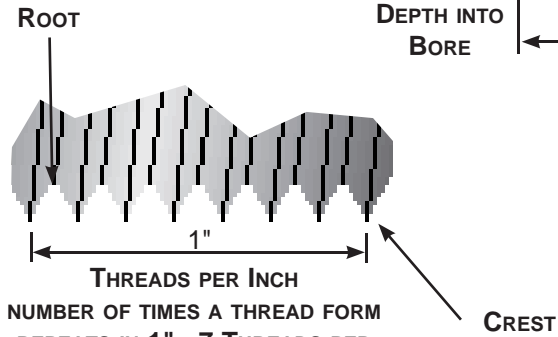
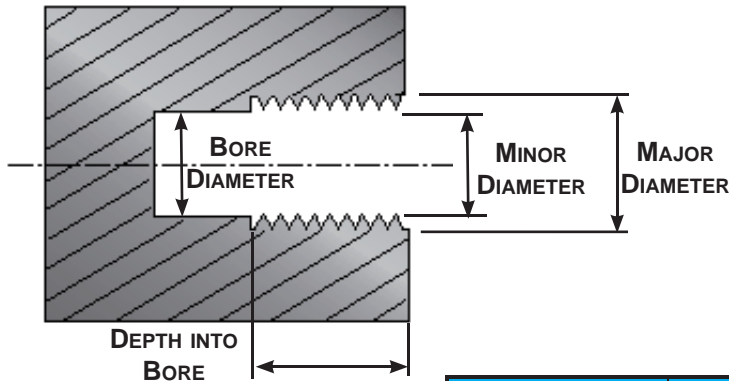

NUMBER OF TIMES A THREAD FORM REPEATS IN 1". 7 THREADS PER INCH SHOWN IN ILLUSTRATION.

PITCH = 1/THREADS PER INCH

DEPTH OF INTERNAL THREADS = .54127 X PITCH

DEPTH OF EXTERNAL THREADS = .86603 X PITCH

Thread Orientation	Feed Direction Relative to Spindle	Chuck Rotation
Right Hand, External	Toward	Counter-Clockwise
	Away	Clockwise
Left Hand, External	Toward	Clockwise
	Away	Counter-Clockwise
Right Hand, Internal	Toward	Counter-Clockwise
	Away	Clockwise
Left Hand, Internal	Toward	Clockwise
	Away	Counter-Clockwise

KAISER TOOL COMPANY, INC.

Speeds & Feeds - Threading

Material To Be Cut		Carbide Grade	Speed (SFM)		Infeed Per Pass (IPR)	
			Carbide	HSS	1st Pass	Last Pass
Aluminum	2021-6061	DURA-MAX® 5000	100-200	80-150	.020	.001
Brass		DURA-MAX® 5000	200-300	50-150	.010	.001
Bronze		DURA-MAX® 5000	200-300	50-150	.010	.001
Cast Iron	Gray, Ductile, Malleable	DURA-MAX® 2000	85-140	25-50	.015	.0005
Copper	101-757, 834-978	DURA-MAX® 5000	100-200	30-100	.010	.001
Magnesium	AZ, AM, EZ, ZE, HK Types	DURA-MAX® 5000	100-200	80-150	.020	.001
Nickel	Nickel 200-230, Monel, Inconel	DURA-MAX® 5000	40-100	20-25	.015	.001
	Waspaloy, Hastelloy	DURA-MAX® 5000	40-100	20-25	.015	.001
Plastic	Teflon (TFE, CTFE)	DURA-MAX® 5000	250-400	100-300	.015	.001
	Nylon	DURA-MAX® 5000	250-400	100-300	.015	.001
	Phenolic	DURA-MAX® 5000	250-400	100-300	.015	.001
	Glass Filled	DURA-MAX® 5000	250-400	NA	.015	.001
Stainless Steels	201-385	DURA-MAX® 5000	65-100	8-20	.015	.001
	405-446	DURA-MAX® 2000	65-100	8-20	.015	.001
	14-4, 15-5, 16-6, 17-4 PH	DURA-MAX® 2000	65-100	8-20	.015	.001
Steel	1005-1029, 1030-1055	DURA-MAX® 2000	50-150	30-40	.015	.001
	1060-1095, 10L45-10L50	DURA-MAX® 2000	50-150	30-40	.015	.001
	12L13-12L15, 41L30-41L50	DURA-MAX® 2000	50-150	30-40	.015	.001
	4140-4150, 4140 (35 HRC)	DURA-MAX® 2000	50-150	30-40	.015	.001
	8617-8622, M1-M6	DURA-MAX® 2000	50-150	30-40	.015	.001
	D2-D7, A2-A9, 01-07	DURA-MAX® 2000	50-150	30-40	.015	.001
	W1, W2, M-50, 52100	DURA-MAX® 2000	50-150	30-40	.015	.001
Titanium	Ti-6Al-6V	DURA-MAX® 5000	40-65	5-9	.020	.0005

Single Point Threading - Roughing Infeed Depth per Pass

(Based on Equal Areas of Material Removal per Pass)

Pass	Threads Per Inch													
	8	10	11	12	13	14	16	18	20	24	28	32	36	40
1st	.017	.015	.013	.013	.012	.011	.011	.011	.010	.009	.008	.008	.007	.008
2nd	.028	.024	.022	.022	.020	.019	.018	.018	.016	.015	.013	.013	.011	.013
3rd	.037	.032	.029	.029	.026	.024	.023	.023	.021	.019	.016	.017	.015	
4th	.045	.038	.035	.035	.032	.029	.028	.028	.025	.023	.019			
5th	.052	.044	.040	.040	.036	.034	.032	.032	.028					
6th	.058	.049	.045	.044	.041	.038	.036							
7th	.064	.054	.049	.049	.045	.041								
8th	.069	.059	.053											
9th	.074													

Note: One or more finish passes will be necessary to finish the thread

THESE SPEEDS AND FEEDS ARE GIVEN AS A STARTING POINT ONLY AND MAY BE ADJUSTED UP OR DOWN DEPENDING ON CONDITIONS. ANY TIME THERE IS AN INTERRUPTED CUT IN YOUR OPERATION, **DURA-MAX® 2000** CARBIDE IS RECOMMENDED.

FORMULA FOR CONVERSION FROM SFM TO RPM

SFM = SURFACE FEET PER MINUTE RPM = REVOLUTIONS PER MINUTE

IPR = INCHES PER REVOLUTION

DIAMETER = CUTTING DIAMETER

$\pi = 3.14$

$$RPM = \frac{SFM \times 12}{\pi \times DIAMETER}$$

KAISER TOOL COMPANY, INC.

Phone: 888-THINBIT (888-844-6248) or (260) 484-3620 • Fax: 888-THINFAX (888-844-6329) or (260) 482-1881
www.thinbit.com • General E-mail: thinbit@kaisertool.com • Orders: orders@thinbit.com • Quotes: quotes@thinbit.com

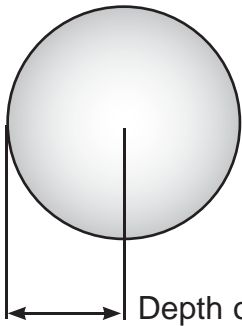

Depth of Cut to part
Solid:

Divide outside diameter by 2

Example: 1" outside diameter

$$\frac{1"}{2} = .5" \text{ depth of cut to part}$$

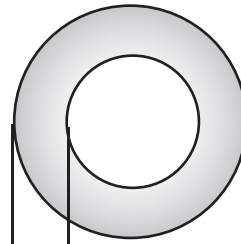

Depth of Cut to part
Tubing:

Subtract inside diameter from
outside diameter and divide by 2

Example: 1" outside diameter with
.5" inside diameter.

$$\frac{1"-.5"}{2} = .25" \text{ depth of cut to part}$$

External Parting Applications

Decrease surface speed (SFM)

Increase depth of cut per pass

Set tool on center to .005" below center. Keep smaller inserts closer to center.

Modify Parameter →

Tool starts with:	LGPT025 SPT025	LGPT045 SPT045	LGPT062 SPT062	LGPT085 LPT085	LGPT115 LPT115
-------------------	-------------------	-------------------	-------------------	-------------------	-------------------

Speeds & Feeds - Parting						
Material To Be Cut		Carbide Grade	Carbide		High Speed Steel	
			Speed (SFM)	Feed (IPR)	Speed (SFM)	Feed (IPR)
Aluminum	2021-6061	DURA-MAX [®] 5000	650-1100	.002-.004	300-500	.002-.004
Brass		DURA-MAX [®] 5000	200-350	.001-.003	50-100	.001-.003
Bronze		DURA-MAX [®] 5000	200-350	.001-.003	50-100	.001-.003
Cast Iron	Gray	DURA-MAX [®] 5000	100-350	.0015-.005	30-125	.0015-.005
	Ductile	DURA-MAX [®] 2000	200-400	.003-.006	100-200	.003-.006
	Malleable	DURA-MAX [®] 2000	250-550	.003-.006	100-200	.003-.006
Copper	101-757	DURA-MAX [®] 5000	150-300	.002-.004	50-150	.002-.004
	834-978	DURA-MAX [®] 5000	250-600	.002-.006	100-450	.002-.006
Magnesium	AZ, AM, EZ, ZE, HK Types	DURA-MAX [®] 5000	600-1000	.002-.004	300-500	.002-.004
Nickel	Nickel 200-230	DURA-MAX [®] 5000	200-350	.002-.004	50-100	.002-.004
	Monel	DURA-MAX [®] 5000	100-250	.0025-.003	30-80	.002-.003
	Inconel, Waspaloy	DURA-MAX [®] 5000	50-150	.002-.004	25-75	.001-.003
	Hastelloy	DURA-MAX [®] 5000	50-150	.002-.004	25-75	.001-.003
Plastic	Teflon (TFE, CTFE)	DURA-MAX [®] 5000	300-600	.002-.006	100-300	.002-.006
	Nylon	DURA-MAX [®] 5000	250-400	.002-.005	NA	NA
	Phenolic	DURA-MAX [®] 5000	250-400	.002-.005	200-350	.002-.005
	Glass Filled	DURA-MAX [®] 5000	200-350	.002-.007	NA	NA
Stainless Steels	201-385	DURA-MAX [®] 5000	200-350	.002-.004	75-150	.001-.003
	405-446	DURA-MAX [®] 2000	250-450	.002-.003	50-100	.001-.003
	14-4, 15-5, 16-6, 17-4 PH	DURA-MAX [®] 2000	200-350	.002-.003	50-100	.001-.003
Steel	1005-1029	DURA-MAX [®] 2000	250-400	.0015-.004	100-200	.0015-.004
	1030-1055	DURA-MAX [®] 2000	200-325	.001-.003	75-100	.001-.003
	1060-1095	DURA-MAX [®] 2000	150-300	.001-.003	60-100	.001-.003
	10L45-10L50	DURA-MAX [®] 2000	250-400	.001-.003	100-200	.001-.003
	12L13-12L15	DURA-MAX [®] 2000	250-550	.002-.005	100-300	.002-.005
	41L30-41L50	DURA-MAX [®] 5000	150-400	.002-.005	45-150	.002-.005
	4140-4150	DURA-MAX [®] 2000	150-400	.002-.005	45-150	.002-.005
	4140 (35 HRc)	DURA-MAX [®] 2000	100-250	.001-.004	30-75	.001-.004
	8617-8622	DURA-MAX [®] 2000	150-400	.002-.004	50-150	.001-.004
	M1-M6	DURA-MAX [®] 2000	150-300	.001-.002	50-150	.001-.002
	H10-H19	DURA-MAX [®] 2000	100-350	.001-.002	50-150	.001-.002
	D2-D7	DURA-MAX [®] 2000	100-300	.001-.002	50-100	.001-.002
	A2-A9, 01-07	DURA-MAX [®] 2000	100-300	.001-.0025	100-200	.001-.002
	W1, W2	DURA-MAX [®] 2000	200-400	.002-.0035	75-175	.001-.003
	M-50, 52100	DURA-MAX [®] 2000	175-350	.0015-.004	50-125	.001-.0035
Titanium	Ti-6Al-6V	DURA-MAX [®] 5000	150-350	.0015-.004	30-100	.001-.003

THESE SPEEDS AND FEEDS ARE GIVEN AS A STARTING POINT ONLY AND MAY BE ADJUSTED UP OR DOWN DEPENDING ON CONDITIONS. ANY TIME THERE IS AN INTERRUPTED CUT IN YOUR OPERATION, **DURA-MAX[®] 2000** CARBIDE IS RECOMMENDED.

FORMULA FOR CONVERSION FROM SFM TO RPM

SFM = SURFACE FEET PER MINUTE RPM = REVOLUTIONS PER MINUTE IPR = INCHES PER REVOLUTION DIAMETER = CUTTING DIAMETER $\pi = 3.14$

$$RPM = \frac{SFM \times 12}{(\pi) \times DIAMETER}$$

KAISER TOOL COMPANY, INC.

Phone: 888-THINBIT (888-844-6248) or (260) 484-3620 • Fax: 888-THINFAX (888-844-6329) or (260) 482-1881
www.thinbit.com • General E-mail: thinbit@kaisertool.com • Orders: orders@thinbit.com • Quotes: quotes@thinbit.com