

FRONT RAKE:  
 CARBIDE: Primary 10° honed, Secondary 15°  
 HIGH SPEED STEEL: 15°  
 BACK CLEARANCE: 2-1/2° both sides  
 SIDE CLEARANCE: 0° both sides  
 RADIUS: None  
 TOP RAKE: 0°  
 LEAD ANGLE: 0°

**GENERAL INFORMATION**

- This insert style will cut to within 1/16" of a shoulder. To work against a shoulder see Page 1-10.
- Uncoated **DURA-MAX<sup>®</sup> 2000** and **5000** Carbides and High Speed Steel stocked for 24-72 hour shipment.

## ORDERING INSTRUCTIONS

Complete the **ORDER CODE** in the table below that represents your selection of groove width and insert grade.

EXAMPLE:

The **ORDER CODE** for an .093" groove width insert in **DURA-MAX<sup>®</sup> 2000** is:

**LG1 093 D2**

Specify the INSERT WIDTH 'A'

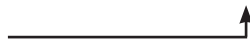

SPECIFICATIONS		ORDER CODE						INFORMATION		
Insert Width Range  'A'  +.0009/-0.0000	Depth of Cut  'B'	Insert Grades <small>See Page 9-5 for expanded material descriptions and Page 9-10 for speeds and feeds information</small>			Add-ons <small>Use 'Order Code' and Add</small>			Blank Width  'C'	Overall Length  'D'	Toolholder Catalog Section 7 & 10  Use Toolholders Beginning With
		DURA-MAX <sup>®</sup> 2000 Carbide <small>For Steel &amp; Interrupted Cutting</small>	DURA-MAX <sup>®</sup> 5000 Carbide <small>For Aluminum &amp; Non-ferrous</small>	High Speed Steel	Full Radius Page 8-3	Corner Radius Page 8-3	Coating Page 9-6			
.004"-.034"	3 x 'A'	SGI ___ D2	SGI ___ D5	SGI ___ HS	add 'FR'	add 'CR___'  (indicate size in .xxx")	TiN add 'C'	.068"	.650"	"S" "EM" "ROM"
.035"-.063"	.100"						TiCN add 'D'			
.064"-.095"	1.5 x 'A'	LGI ___ D2	LGI ___ D5	LGI ___ HS			TiAlN add 'E'	.130"	.721"	"L" "EM" "ROM"
.096"-.125"							Diamond add 'F'			

### KAISER TOOL COMPANY, INC.

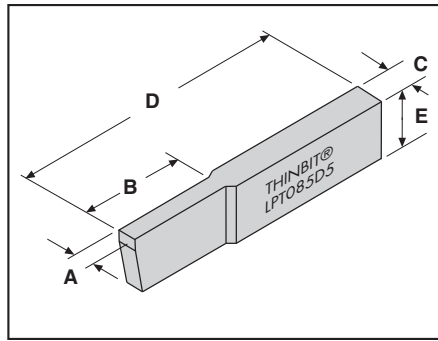

FRONT RAKE:  
 CARBIDE: Primary 7° honed, Secondary 15°  
 HIGH SPEED STEEL: 15° on SPT025HS,  
 7° all others

BACK CLEARANCE: 0° SPT045HS and  
 SPT062HS; 1° all others

SIDE CLEARANCE: 1°

RADIUS: None

TOP RAKE: 0°

LEAD ANGLE: 0°

<b>GENERAL INFORMATION</b>	<ul style="list-style-type: none"> <li>This insert style will cut to within 1/16" of a shoulder.</li> <li>Uncoated <b>DURA-MAX® 2000</b> and <b>5000</b> Carbides and High Speed Steel stocked for 24-72 hour shipment.</li> </ul>
----------------------------	--

## ORDERING INSTRUCTIONS

Select the **ORDER CODE** in the table below that represents your selection of groove width and insert grade.

**EXAMPLE:**

The **ORDER CODE** for an .085" wide parting insert in **DURA-MAX® 5000** is:  
**LPT085D5**

SPECIFICATIONS		ORDER CODE						INFORMATION				
Groove Width	Depth of Cut	Insert Grades <small>See Pages 9-5 for expanded material descriptions and Page 9-20 for speeds and feeds information</small>			Coatings <small>See Page 9-6 for expanded coating descriptions</small>			Blank Width	Overall Length	Blank Height	Toolholder Catalog Section 7 & 10	
'A'	'B'	DURA-MAX® 2000 Carbide <small>For Steel &amp; Interrupted Cutting</small>	DURA-MAX® 5000 Carbide <small>For Aluminum &amp; Non-ferrous</small>	High Speed Steel	Use uncoated part number and add coating code				'C'	'D'	'E'	Use Toolholders Beginning With
					TiN	TiCN	TiAlN	Diamond				
.025"	.200"	SPT025D2	SPT025D5	SPT025HS					.068"	.650"	.240"	"S" "EM" "ROM"
.045"	.500"	SPT045D2	SPT045D5	SPT045HS	add 'C'	add 'D'	add 'E'	add 'F'		1.000"		
.062"		SPT062D2	SPT062D5	SPT062HS								
.085"	.500"	LPT085D2	LPT085D5		add 'C'	add 'D'	add 'E'	add 'F'	.125"	1.000"	.238"	"L" "EM" "ROM"
.115"		LPT115D2	LPT115D5							.232"		

### KAISER TOOL COMPANY, INC.

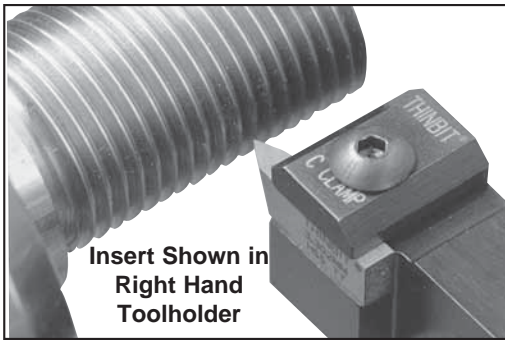

Insert Shown in Right Hand Toolholder

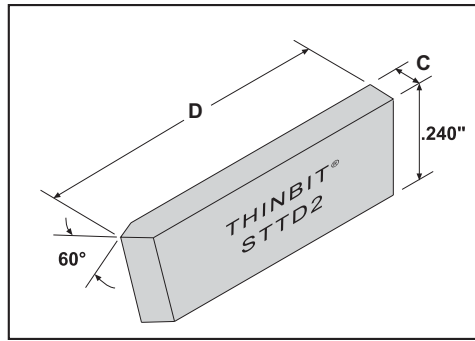

FRONT RAKE: 15°  
 RADIUS: .002" or .000"  
 TOP RAKE: 0°

**GENERAL INFORMATION**

- Uncoated **DURA-MAX<sup>®</sup> 2000** and **5000** Carbides and High Speed Steel stocked for 24-72 hour shipment.

## ORDERING INSTRUCTIONS

Complete the **ORDER CODE** in the table below that represents your selection of Threads Per Inch and insert grade.

**EXAMPLE:**

The **ORDER CODE** for an 15-56 TPI insert in **DURA-MAX<sup>®</sup> 2000** is:  
**STTD2**

SPECIFICATIONS		ORDER CODE							INFO.		
Insert Orientation	Threads Per Inch	Insert Grades See Page 9-5 for expanded material selections and Page 9-18 for speeds and feeds information			Coatings See Page 9-6 for Expanded Coating Descriptions				Blank Width 'C'	Overall Length 'D'	Toolholder Catalog Section 7 & 10 Use Toolholders Beginning With
		DURA-MAX <sup>®</sup> 2000 Carbide For Steel & Interrupted Cutting	DURA-MAX <sup>®</sup> 5000 Carbide For Aluminum & Non-ferrous	High Speed Steel	Use Uncoated Part Number and Add Coating Code						
					TiN	TiCN	TiAlN	Diamond			
Centered For either right hand or left hand	15 to 56	STTD2	STTD5	STTHS					.068"	.650"	"S"
	Greater than 56	STTD21	STTD51	STTHS1	add 'C'	add 'D'	add 'E'	add 'F'			
	8 to 56	LTTD2	LTTD5	LTTHS					.130"	.721"	"L"
	Greater than 56	LTTD21	LTTD51	LTTHS1	add 'C'	add 'D'	add 'E'	add 'F'			

### KAISER TOOL COMPANY, INC.

FRONT RAKE: 7° on SGP068HS; 15° all others

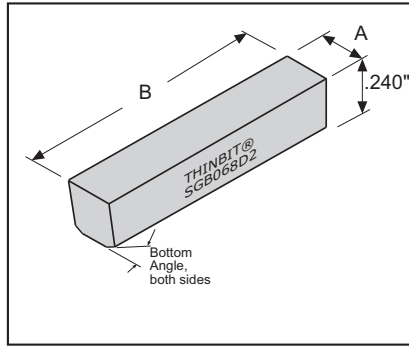

## GROUND BLANK ORDERING INSTRUCTIONS

Select the **ORDER CODE** in the table below that represents your selection of blank width and insert grade.

**EXAMPLE:**

The **ORDER CODE** for a .068" wide blank and .654" length in **DURA-MAX® 2000** is:  
**SGB068D2**

SPECIFICATIONS			ORDER CODE			INFO.
Blank Width 'A'	Overall Length 'B'	Bottom Angle	Insert Grades See Page 9-5 for expanded material descriptions			Use Toolholders Beginning With
			DURA-MAX® 2000 Carbide For Steel & Interrupted Cutting	DURA-MAX® 5000 Carbide For Aluminum & Non-ferrous	High Speed Steel	
.068"	.654"	0°	SGB068D2	SGB068D5	SGB068HS	'S'
	1.004"	0°	SGP068D2	SGP068D5	SGP068HS	
.125"	1.004"	0°	LGP125D2	LGP125D5		'L'
.130"	.725"	10°	LGB130D2	LGB130D5	LGB130HS	

## SET ORDERING INSTRUCTIONS

Select the **ORDER CODE** in the table below that represents your selection of insert width(s) and insert grade.

For '1 Each' set types, specify the size range with the 'Order Code'

**EXAMPLE:**

The **ORDER CODE** for a '1 Each' set type, in **DURA-MAX® 2000** with a groove width range of .010 - .030 is:  
**SSET2D2**

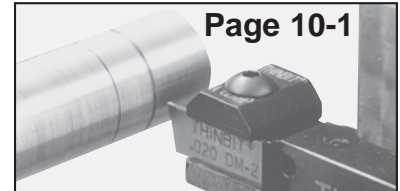

SPECIFICATIONS			ORDER CODE		
Toolholder Type	Set Type	Insert Width 'A' See Page 10-1	Insert Grades See Page 9-5 for expanded material descriptions and Page 9-10 for speeds and feeds information		
			DURA-MAX® 2000 Carbide For Steel & Interrupted Cutting Uncoated	DURA-MAX® 5000 Carbide For Aluminum & Non-ferrous Uncoated	High Speed Steel
Inserts only; Use toolholders beginning with 'S'	1 Each, by .001" increments Inserts Only	.004"-.009"	SSET1D2	SSET1D5	SSET1HS
		.010"-.030"	SSET2D2	SSET2D5	SSET2HS
		.031"-.050"	SSET3D2	SSET3D5	SSET3HS
		.051"-.063"	SSET4D2	SSET4D5	SSET4HS
Inserts only; Use toolholders beginning with 'L'	1 Each, by .001" increments Inserts Only	.064"-.084"	LSET1D2	LSET1D5	LSET1HS
		.085"-.105"	LSET2D2	LSET2D5	LSET2HS
		.106"-.125"	LSET3D2	LSET3D5	LSET3HS

### KAISER TOOL COMPANY, INC.

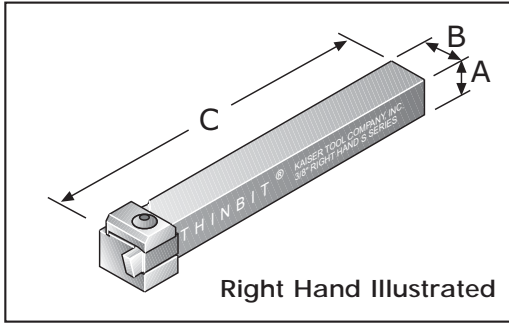

### FLUSHTOP ORDERING INSTRUCTIONS

Select the **ORDER CODE** in the table below that represents your selection of shank orientation and dimensions.

**EXAMPLE:**

The **ORDER CODE** for a .375" shank, right hand flushtop tool for inserts beginning with 'L' is:

**LFT38R**

SPECIFICATIONS				ORDER CODE					
Shank Orientation	Shank Dimensions			Toolholder Package Includes Shank, Clamp and Hardware		Replacement Parts			
	'A'	'B'	'C'	For Inserts Beginning With		Clamp	Screw	Wrench	Pin
				'S'	'L'				
Right Hand  Use with right hand and centered inserts	.312"	.312"	4.840"	SFT56R	---	Clamp A	S5608	W1005	P0308
				---	LFT56R	Clamp C	S3808		
	.375"	.375"	4.840"	SFT38R	---	Clamp A	S5608		
				---	LFT38R	Clamp C	S3808		
	.500"	.500"	4.840"	SFT12R	LFT12R	Clamp C	S3808		
	.625"	.625"	4.840"	SFT58R	---	Clamp C	S3808		
		.500"	4.840"	---	LFT58R	Clamp C	S3808		
Left Hand  Use with left hand and centered inserts	.312"	.312"	4.840"	SFT56L	---	Clamp A	S5608		
				---	LFT56L	Clamp C	S3808		
	.375"	.375"	4.840"	SFT38L	---	Clamp A	S5608		
				---	LFT38L	Clamp C	S3808		
	.500"	.500"	4.840"	SFT12L	LFT12L	Clamp C	S3808		
	.625"	.625"	4.840"	SFT58L	---	Clamp C	S3808		
		.500"	4.840"	---	LFT58L	Clamp C	S3808		

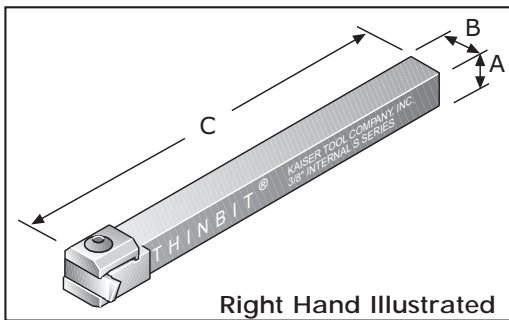

### HARDINGE ORDERING INSTRUCTIONS

Select the **ORDER CODE** in the table below that represents your selection of shank orientation and dimensions.

**EXAMPLE:**

The **ORDER CODE** for a .375" shank, right hand tool for inserts beginning with 'L' is:

**LHA38**

SPECIFICATIONS				ORDER CODE						
Shank Orientation	Shank Dimensions			Minimum Bore Diameter  with 'S' inserts; add .071" for 'L' inserts	Toolholder Package Includes Shank, Clamp and Hardware		Replacement Parts			
	'A'	'B'	'C'		For Inserts Beginning With		Clamp	Screw	Wrench	Pin
					'S'	'L'				
Right Hand  Use with left hand and centered inserts	.375"	.375"	4.840"	1.050"	SHA38	---	Clamp C	S3808	W1005	P0308
					---	LHA38				
	.500"	.500"	4.840"	1.290"	SHA12	LHA12				
Left Hand  Use with right hand and centered inserts	.375"	.375"	4.840"	1.050"	SHA38	---				
					---	LHA38				
	.500"	.500"	4.840"	1.290"	SHA12	LHA12				

### KAISER TOOL COMPANY, INC.

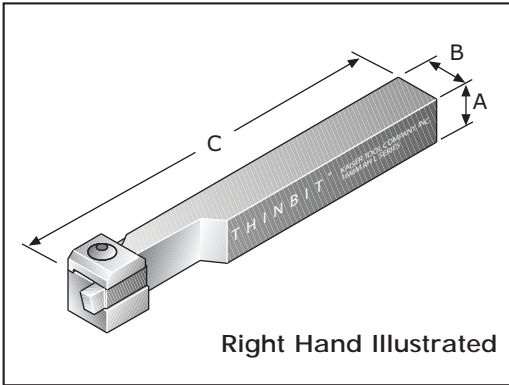

### SWISS SCREW ORDERING INSTRUCTIONS

Select the **ORDER CODE** in the table below that represents your selection of shank orientation and dimensions.

**EXAMPLE:**

The **ORDER CODE** for a .500" shank, right hand tool for inserts beginning with 'L' is:

**LSS12R**

SPECIFICATIONS				ORDER CODE							
Shank Orientation	Shank Dimensions			Toolholder Package Includes Shank, Clamp and Hardware		Replacement Parts					
	'A'	'B'	'C'	For Inserts Beginning With		Clamp		Screw		Wrench	Pin
				'S'	'L'	'S'	'L'	'S'	'L'		
Right Hand  Use with right hand and centered inserts	.375"	.375"	4.840"	SSS38R	---	A	--	S5608	---	W1005	P0206
	.500"	.500"		SSS12R	LSS12R	A	C	S5608	S3808		
	10mm	10mm		SSS10RM	---	A	--	S5608	---		
	12mm	12mm		SSS12RM	LSS12RM	A	C	S5608	S3808		
	16mm	16mm		SSS16RM	LSS16RM	C	C	S3808	S3808		
Left Hand  Use with left hand and centered inserts	.375"	.375"	4.840"	SSS38L	---	A	--	S5608	---	W1005	P0206
	.500"	.500"		SSS12L	LSS12L	A	C	S5608	S3808		
	10mm	10mm		SSS10LM	---	A	--	S5608	---		
	12mm	12mm		SSS12LM	LSS12LM	A	C	S5608	S3808		
	16mm	16mm		SSS16LM	LSS16LM	C	C	S3808	S3808		

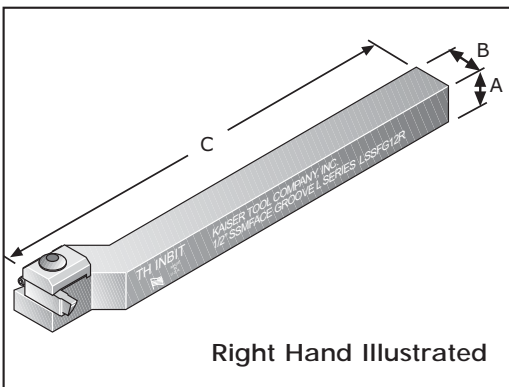

### SWISS FACE ORDERING INSTRUCTIONS

Select the **ORDER CODE** in the table below that represents your selection of shank orientation and dimensions.

**EXAMPLE:**

The **ORDER CODE** for a .375" shank, right hand tool for inserts beginning with 'L' is:

**LSSFG38R**

SPECIFICATIONS				ORDER CODE							
Shank Orientation	Shank Dimensions			Toolholder Package Includes Shank, Clamp and Hardware		Replacement Parts					
	'A'	'B'	'C'	For Inserts Beginning With		Clamp		Screw		Wrench	Pin
				'S'	'L'			'S'	'L'		
Right Hand  Use with left hand and centered inserts for counter-clockwise rotation	.375"	.375"	4.840"	SSSFG38R	LSSFG38R	Clamp C		S3808	S3808	W1005	P0203
	.500"	.500"	4.840"	SSSFG12R	LSSFG12R			S3808			
	10mm	10mm	4.840"	SSSFG10RM	LSSFG10RM			S5452			
	12mm	12mm	4.840"	SSSFG12RM	LSSFG12RM			S5452			
	16mm	16mm	4.840"	SSSFG16RM	LSSFG16RM			S3808			

### KAISER TOOL COMPANY, INC.

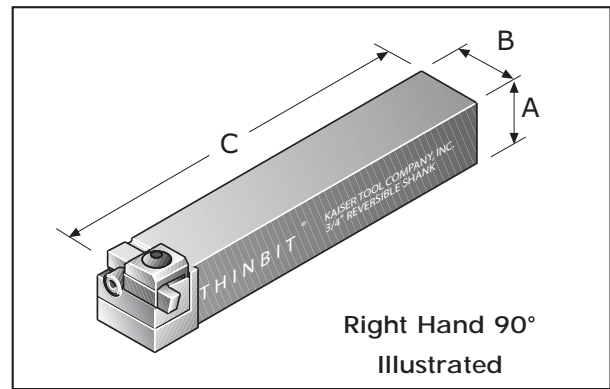
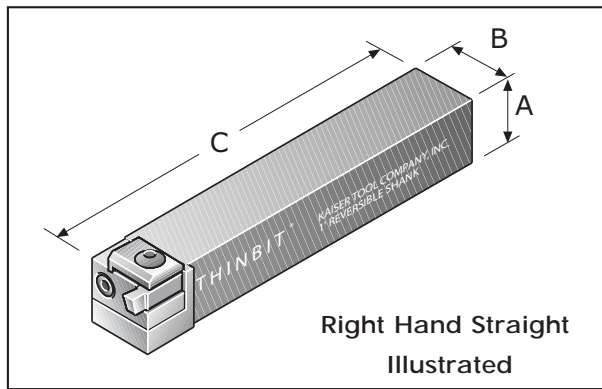

## ORDERING INSTRUCTIONS

Select the **ORDER CODE** in the table below that represents your selection of shank orientation and dimensions.

**EXAMPLE:**

The **ORDER CODE** for a .750" shank and a 90° right hand tool for inserts beginning with 'L' is:

**LRI3434R**

SPECIFICATIONS				ORDER CODE									
Shank Orientation	Shank Dimensions			Toolholder Package Includes Shank, Head, Clamp and Hardware		Head Only Includes Clamp and Hardware For Inserts Beginning With		Replacement Parts					
	'A'	'B'	'C'	For Inserts Beginning With		'S'	'L'	Head Screws	Head Wrenches	Head Pin	Shank	Clamp	Clamp Hardware
				'S'	'L'								
Straight Right Hand or Left Hand  Use as right hand with right hand inserts; Use as left hand with left hand inserts; Use as either hand with centered inserts.	.375"	.750"	4.840"	SRE3438	LRE3438	SREH34	LREH34	1 each: S3808 S2808	1 each: W1005 W1009		RS3438	ClampC	Screw: S3808  Wrench: W1005
	.500"			SRE3412	LRE3412						RS3412		
	.625"			SRE3458	LRE3458						RS3458		
	.750"			SRE3434	LRE3434						RS3434		
	.750"	1.000"	4.840"	SRE0134	LRE0134	SREH01	LREH01	1 each: S3812 S2808	1 each: W1005 W1009		RS0134		
	1.000"			SRE0101	LRE0101						RS0101		
	1.000"			SRE1401	LRE1401						RS1401		
1.250"	1.250"	4.840"	SRE1414	LRE1414	SREH14	LREH14	1 each: S3816 S2808	1 each: W1005 W1009		RS1414			
90° Right Hand Use with left hand and centered inserts	.375"	.750"	4.840"	SRI3438R	LRI3438R	SRIH34R	LRIH34R	1 each: S3808 S2808	1 each: W1005 W1009		RS3438	ClampC	Screw: S3808  Wrench: W1005
	.500"			SRI3412R	LRI3412R						RS3412		
	.625"			SRI3458R	LRI3458R						RS3458		
	.750"			SRI3434R	LRI3434R						RS3434		
	.750"	1.000"	4.840"	SRI0134R	LRI0134R	SRIH01R	LRIH01R	1 each: S3812 S2812	1 each: W1005 W1009	P0305	RS0134		
	1.000"			SRI0101R	LRI0101R						RS0101		
90° Left Hand Use with right hand and centered inserts	.375"	.750"	4.840"	SRI3438L	LRI3438L	SRIH34L	LRIH34L	1 each: S3808 S2808	1 each: W1005 W1009		RS3438	ClampC	Wrench: W1005
	.500"			SRI3412L	LRI3412L						RS3412		
	.625"			SRI3458L	LRI3458L						RS3458		
	.750"			SRI3434L	LRI3434L						RS3434		
	.750"	1.000"	4.840"	SRI0134L	LRI0134L	SRIH01L	LRIH01L	1 each: S3812 S2812	1 each: W1005 W1009	P0305	RS0134		
	1.000"			SRI0101L	LRI0101L						RS0101		

### KAISER TOOL COMPANY, INC.

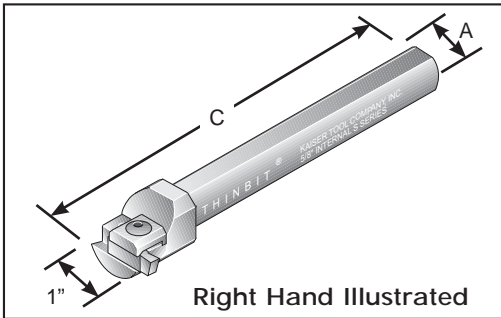

### ROUND INTERNAL ORDERING INSTRUCTIONS

Select the **ORDER CODE** in the table below that represents your selection of shank orientation and dimensions.

**EXAMPLE:**

The **ORDER CODE** for a .625", 5.5" long round shank for inserts beginning with 'L' is:

**LR5806**

SPECIFICATIONS				ORDER CODE					
Shank Orientation	Minimum Bore Diameter without pin	Shank Dimensions		Toolholder Package Includes Shank, Clamp and Hardware For Inserts Beginning With		Replacement Parts			
		'A'	'C'	'S'	'L'	Clamp	Screw	Wrench	Pin
Right Hand or Left Hand  Use as right hand with left hand inserts; Use as left hand with right hand inserts; Use as either hand with centered inserts.	1.125"	.500"	5.500"	SR1206	---	ClampC	S3808	W1005	P0305
		.625"		SR5806	---				
		.750"		SR3406	---				
		1.000"		SRO106	---				
	1.187" (1.250" for insert beginning with 'LGT')	.500"	5.500"	---	LR1206				
		.625"		---	LR5806				
		.750"		---	LR3406				
		1.000"		---	LRO106				
		11.875"	---	LRO112					

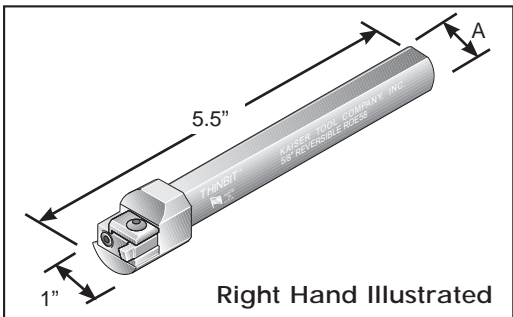

### ROUND REVERSIBLE ORDERING INSTRUCTIONS

Select the **ORDER CODE** in the table below that represents your selection of shank dimensions.

**EXAMPLE:**

The **ORDER CODE** for a .625" round shank for inserts beginning with 'L' is:

**LROE58**

SPECIFICATIONS				ORDER CODE						
Shank Orientation	Shank Dimensions 'A'	Toolholder Package Includes Shank, Head, Clamp and Hardware For Inserts Beginning With		Replacement Parts						
		'S'	'L'	Head Only Includes Clamp and Hardware For Inserts Beginning With		Head Screws	Head Wrenches	Shank	Clamp	Clamp Hardware
Right Hand or Left Hand  Use as right hand with right hand inserts; Use as left hand with left hand inserts; Use as either hand with centered inserts.	.500"	SROE12	LROE12	SROEH	LROEH	1 each: S5806 S2810	1 each: W1006 W1009	RROE12	ClampC	Screw: S3808  Wrench: W1005
	.625"	SROE58	LROE58					RROE58		
	.750"	SROE34	LROE34					RROE34		
	1.000"	SROE01	LROE01					RROE01		

**KAISER TOOL COMPANY, INC.**

**Note:** If groove width is less than .080" it may require a special insert.

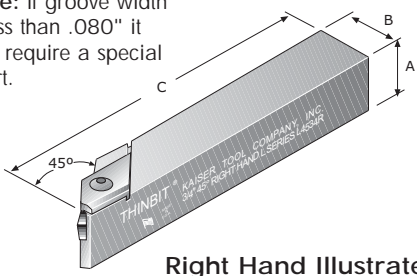

Right Hand Illustrated

## 45° ORDERING INSTRUCTIONS

Select the **ORDER CODE** in the table below that represents your selection of shank orientation and dimensions.

**EXAMPLE:**

The **ORDER CODE** for a .750" shank, right hand tool for inserts beginning with 'L' is:

**L453434R**

SPECIFICATIONS				ORDER CODE					
Shank Orientation	Shank Dimensions			Toolholder Package Includes Shank, Clamp and Hardware		Replacement Parts			
	'A'	'B'	'C'	For Inserts Beginning With		Clamp	Screw	Wrench	Pin
'S'	'L'								
Right Hand Use with left hand and centered inserts for counter-clockwise rotation	.375"	.750"	4.840"	S453438R	L453438R	ClampQ	S3808	W1005	P0204
	.500"			S453412R	L453412R				
	.625"			S453458R	L453458R				
	.750"			S453434R	L453434R				
	1.000"	1.000"	S450101R	L450101R					
Left Hand Use with right hand and centered inserts for clockwise rotation	.375"	.750"	4.840"	S453438L	L453438L	ClampR	S3808	W1005	P0204
	.500"			S453412L	L453412L				
	.625"			S453458L	L453458L				
	.750"			S453458L	L453458L				
	1.000"	1.000"	S450101L	L450101L					

**KAISER TOOL COMPANY, INC.**