

THINBIT®

FORM-A-GROOVE®

FORM-A-GROOVE® tools can consist of combinations of simple grooves or more complex combinations of grooves, arcs, angles, convex and concave radii, as well as special thread forms.

FORM-A-GROOVE® tools can simplify programming, increase production and free tool locations for other tools.

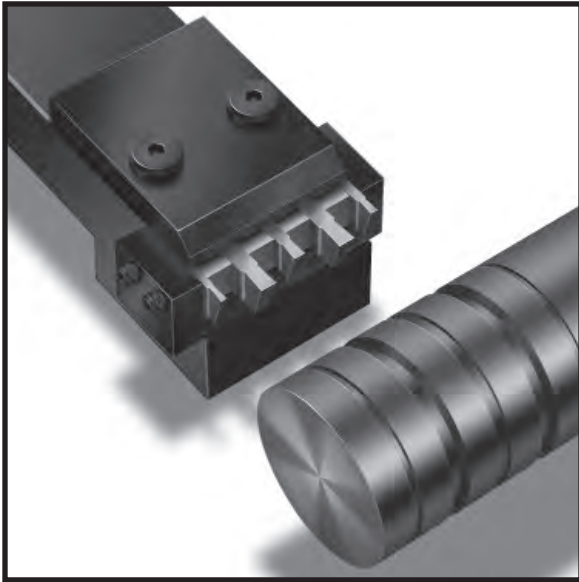

External and Face applications

- Up to 2" wide
- Made from stacking individual inserts or from a solid block of carbide

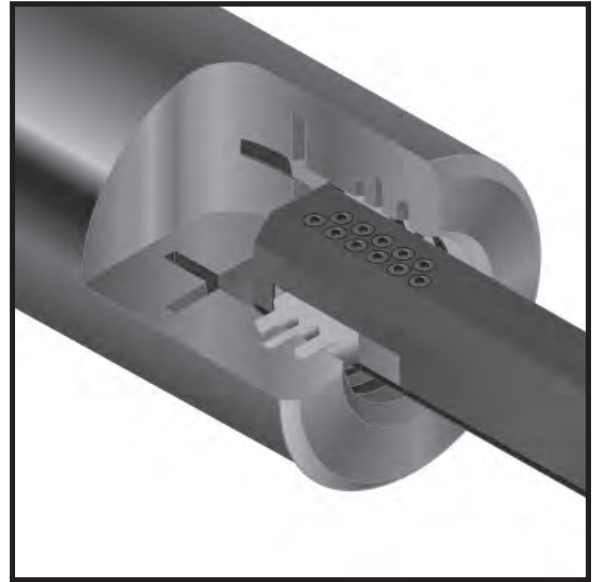

Internal applications

- Up to 1" wide
- Starting at .125" minimum bore

QUOTATION TO ORDER PROCESS

- Submit an application print detailing your requirements. Include company name, contact name, email, telephone and fax numbers. Submissions can be emailed to: **quotes@thinbit.com**.
- A quote will be returned within 48 hours which will include CAD drawings, price, delivery and payment terms.

- Review the quote information and CAD drawings. Fill in the 'Quote Summary Sheet' with item quantities and approval signatures.
- Fax or Email the 'Quote Summary Sheet' to our sales office.
- The order will be confirmed via fax or email. The confirmation will summarize order and include delivery date.



www.thinbit.com/qr8-7

Scan this code
for additional
information

If you require a modification other than those detailed on this page, please call or submit your application print to our sales office.

KAISER TOOL COMPANY, INC.

Phone: 888-THINBIT (888-844-6248) or (260) 484-3620 • Fax: 888-THINFAX (888-844-6329) or (260) 482-1881
www.thinbit.com • General E-mail: thinbit@kaisertool.com • Orders: orders@thinbit.com • Quotes: quotes@thinbit.com

PRODUCT INFORMATION

- Designed to reduce cycle time on those machines with adequate horsepower to handle the tool pressure.
- Pocket is filled with any selection of insert geometry and lengths. Proper edge to edge relation maintained with spacer blocks.
- Shank sizes 3/8", 1/2", 5/8", 3/4" and 1".
- Pocket sizes 1" and 2".
- Modifications can be provided on any of our tooling. Please contact us with your application requirements.

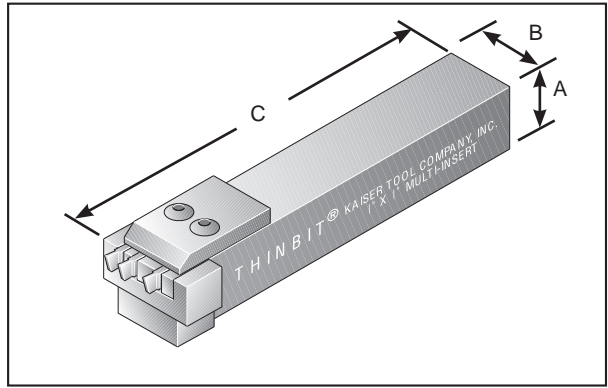

INSERT SELECTION

Due to the potential complexity of configuring these toolholders, we recommend calling for assistance.
See Page 8-7



Scan this code for additional information.

www.thinbit.com/qr7-9

ORDERING INSTRUCTIONS

Select the **ORDER CODE** in the table below that represents your selection of shank dimensions.

EXAMPLE:

The **ORDER CODE** for a 1" pocket on a 1" square shank is:
EMO10101

SPECIFICATIONS				ORDER CODE						
Pocket Size	Shank Dimensions			Toolholder Package Includes Shank, Pocket, Clamp and Hardware	Replacement Parts					
	'A'	'B'	'C'		Call For Inserts	Pocket Includes Hardware Call For Inserts	Pocket Hardware	Backplate	Shank	Clamp
1" Pocket	.375"	1.000"	4.840"	EMO13801	HM0101	Screw: 2 each S1604 S3810	---	ESM0138	Clamp M	Screw: 2 each S3808
	.500"			EMO11201				ESM0112		
	.625"			EMO15801				ESM0158		
	.750"			EMO13401				ESM0134		
	1.000"			EMO10101				ESM0101		
2" Pocket	.375"	1.000"	4.840"	EMO13802	HM0102	Wrench: 1 each: W1004 W1005	Backplate: BP0002 Screws: 4 each S5404	ESM0138	Clamp N	Wrench: W1005
	.500"			EMO11202				ESM0112		
	.625"			EMO15802				ESM0158		
	.750"			EMO13402				ESM0134		
	1.000"			EMO10102				ESM0101		

KAISER TOOL COMPANY, INC.

Phone: 888-THINBIT (888-844-6248) or (260) 484-3620 • Fax: 888-THINFAX (888-844-6329) or (260) 482-1881
www.thinbit.com • General E-mail: thinbit@kaisertool.com • Orders: orders@thinbit.com • Quotes: quotes@thinbit.com

PRODUCT INFORMATION

- Designed to reduce cycle time on those machines with adequate horsepower to handle the tool pressure.
- Pocket is filled with any selection of insert geometry and lengths. Proper edge to edge relation maintained with spacer blocks.
- Shank size 1".
- Pocket size 1".
- Modifications can be provided on any of our tooling. Please contact us with your application requirements.

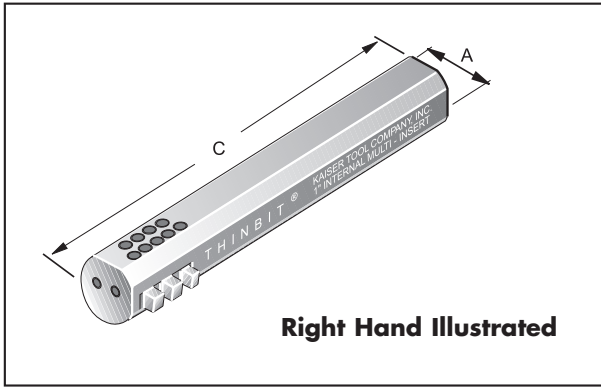

INSERT SELECTION

Due to the potential complexity of configuring these toolholders, we recommend calling for assistance.
See Page 8-7



Scan this code for additional information.

www.thinbit.com/qr7-10

ORDERING INSTRUCTIONS

Select the **ORDER CODE** in the table below that represents your selection of shank dimensions.

EXAMPLE:

The **ORDER CODE** for a 1" right hand shank, 5.5" long is:

ROM0106

SPECIFICATIONS				ORDER CODE				
Pocket Size & Shank Orientation	Minimum Bore Diameter	Shank Dimensions		Toolholder Package Includes Shank and Hardware	Replacement Parts			
		'A'	'C'		Call For Inserts	End Screws	Clamping Screws	Wrench
1" Pocket Right Hand	1.125" Varies depending on configuration	1.000"	5.500"	ROM0106	2 each: S1804	9 each: S1808	W1005	P0001
			11.875"	ROM0112				

MULTI-INSERT TOOLHOLDERS

KAISER TOOL COMPANY, INC.