

THINBIT®

SINCE 1964

888-THINBIT | THINBIT.COM



GROOVING - THREADING - PARTING
BORING - TURNING - FACE GROOVING
CUSTOM TOOLING - FORM TOOLING - MILL TOOLING

2023

SECTION 1: GROOVING

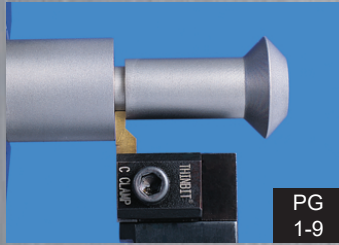

GROOVING AND TURNING
.004" THROUGH .150" IN
.001" INCREMENTS

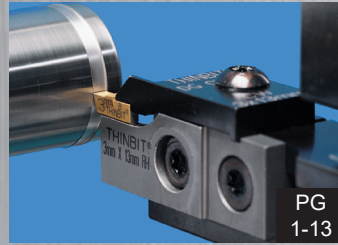

1.000" DEPTH OF CUT
2, 3, 4, 5 AND 6MM
INSERT WIDTHS

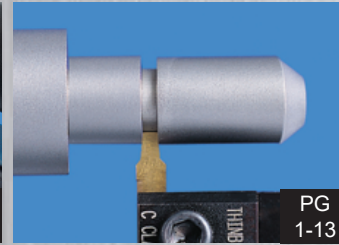

STATIC O-RING GROOVING WITH
1.250" MINIMUM BORE DIAMETER

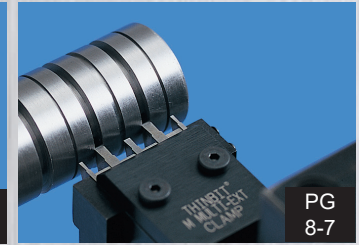

INTERNAL AND EXTERNAL
MULTI - INSERT

SECTION 2: FACE GROOVING

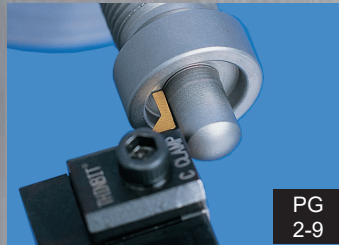

MAJOR DIAMETERS FROM .300"
.004" THROUGH .150" IN
.001" INCREMENTS

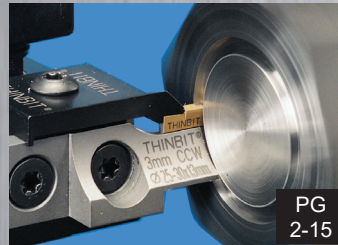

MAJOR DIAMETERS FROM .787";
1" D.O.C.; 2, 3, 4, 5 AND
6MM INSERT WIDTHS

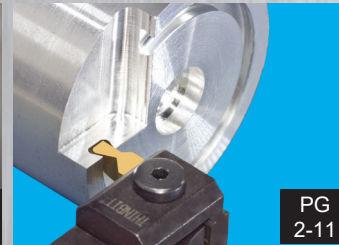

MAJOR DIAMETERS FROM .300";
FOR DOVETAIL O-RING
FACE GROOVING

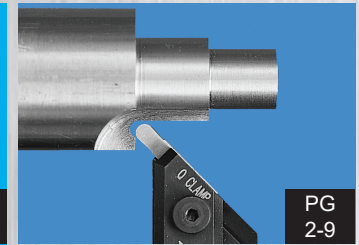

MAJOR DIAMETERS FROM .300"
.004" THROUGH .150" IN
.001" INCREMENTS

THINBIT®

OVER 100,000 TOOLS IN STOCK FOR
GROOVING • THREADING • PARTING
BORING • TURNING • FACE GROOVING
SPECIALS • FORM TOOLS
MILLING

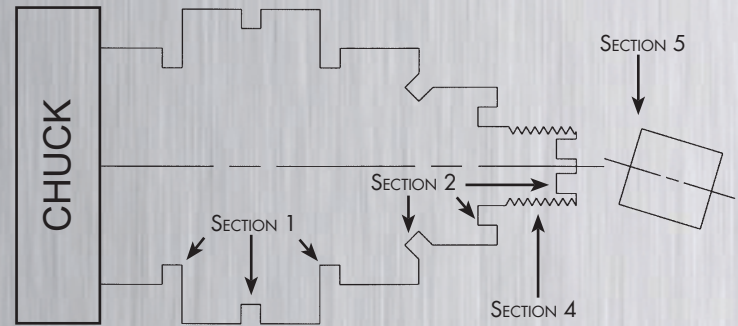

SECTION 4: THREADING AND CHAMFERING

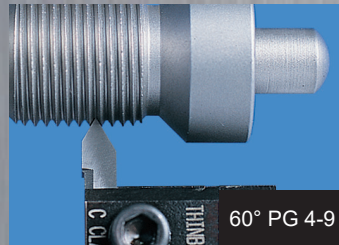

INTERNAL AND EXTERNAL THREADING
8 THREADS PER INCH AND GREATER



ACME EXTERNAL THREADING
4 THREADS PER INCH AND GREATER

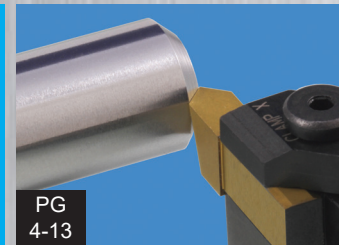

INTERNAL AND EXTERNAL
CHAMFERING
45°

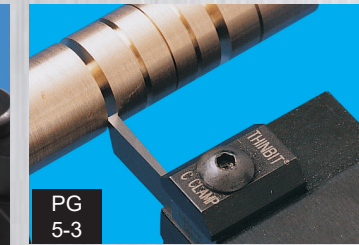

UP TO 1" MATERIAL
.025", .045", .062", .085",
.115" INSERT WIDTHS

MADE IN USA SINCE 1964



KAISER TOOL COMPANY, INC.
3620 CENTENNIAL DRIVE
FORT WAYNE, IN 46808

SECTION 11: MILLING

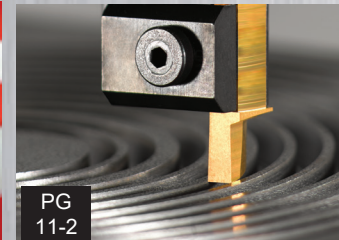

FOR TREPANNING ON A CNC OR
CONVENTIONAL MILLING MACHINE

SECTION 1: GROOVING

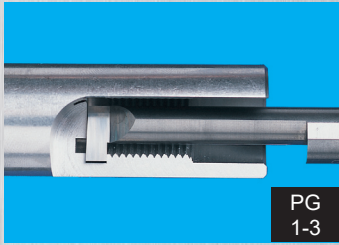

.125" MINIMUM BORE DIAMETER
.004" THROUGH .250"
IN .001" INCREMENTS

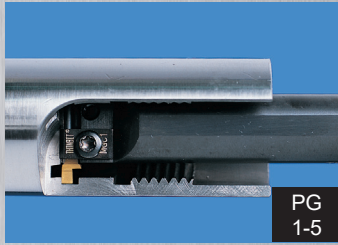

.325" MINIMUM BORE DIAMETER
.004" THROUGH .125"
IN .001" INCREMENTS

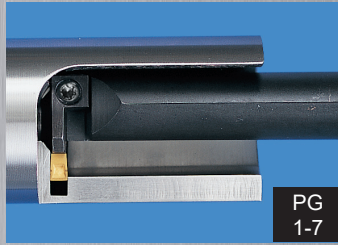

1.000" MINIMUM BORE DIAMETER;
2MM, 3MM AND 4MM
INSERT WIDTHS

SECTION 2: FACE GROOVING



MAJOR DIAMETERS FROM .125"
.004" THROUGH .250"
IN .001" INCREMENTS



MAJOR DIAMETERS FROM .415"
.004" THROUGH .125"
IN .001" INCREMENTS

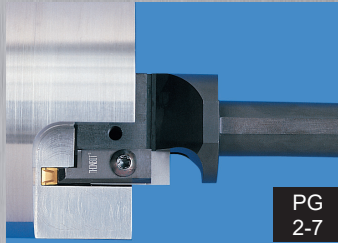

MAJOR DIAMETERS FROM 1.574"
2, 3, 4, 5 AND 6MM
INSERT WIDTHS

TOOLHOLDERS
SECTION 7

MODIFICATIONS
SECTION 8

TECHNICAL
SECTION 9

LITTLEBIT®
SECTION 10

FOR MORE COMPLETE
APPLICATION REFERENCE
CHARTS, REFER TO
PAGES 9-3 & 9-4

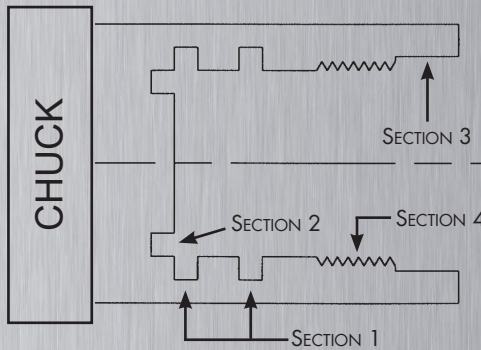

www.thinbit.com
E-MAIL: thinbit@kaisertool.com
ORDERS: orders@thinbit.com
QUOTES: quotes@thinbit.com

SECTION 3: BORING

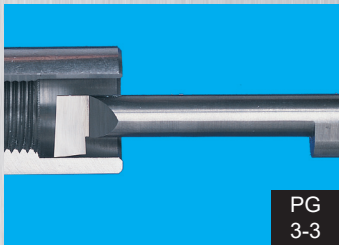

.073" MINIMUM BORE DIAMETER
SOLID CARBIDE TOOLING

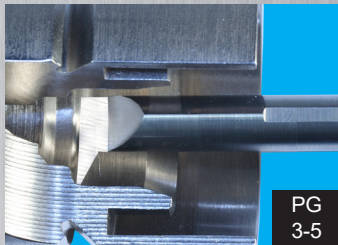

.125" MINIMUM BORE DIAMETER
PROFILING
SOLID CARBIDE TOOLING



.165" MINIMUM BORE DIAMETER
CD, TD, TP AND WCGT INSERT
STYLES

Phone: 888-THINBIT
(888-844-6248)
(260) 484-3620

SECTION 4: THREADING

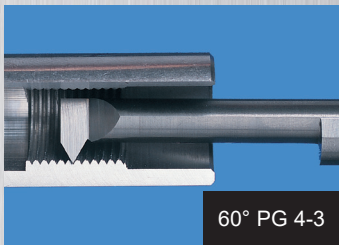

.077" MINIMUM BORE DIAMETER
4 THREADS PER INCH AND GREATER

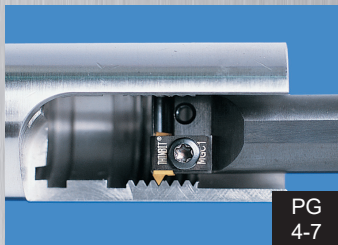

.325" MINIMUM BORE DIAMETER
9 THREADS PER INCH AND GREATER

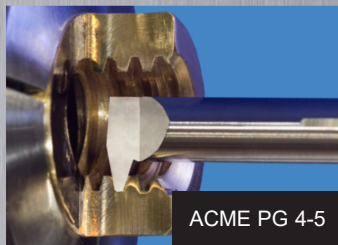

.187" MINIMUM BORE DIAMETER
6 THREADS PER INCH AND GREATER

MADE IN
THE USA?
DAMN RIGHT.

New Products!



Mill A Groove®
Page 11-2



**Heavy Duty Round
Reversible Toolholder**
Page 7-7

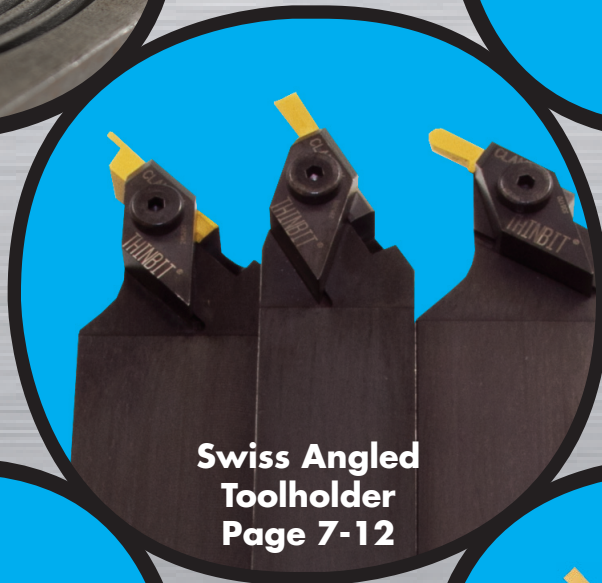

**Swiss Angled
Toolholder**
Page 7-12



**Square Angled
Toolholders**
Page 7-12



**Round Angled
Toolholders**
Page 7-14



THINBIT® 24/7

www.thinbit.com

E-MAIL: thinbit@kaisertool.com

ORDERS: orders@thinbit.com

QUOTES: quotes@thinbit.com



THINBIT®

KAISER TOOL COMPANY, INC.

3620 Centennial Drive • Fort Wayne, IN 46808
P.O. Box 80430 • Fort Wayne, IN 46898-0430

Phone: 888-THINBIT (888-844-6248) • (260) 484-3620

Web: www.thinbit.com

General E-mail: thinbit@kaisertool.com

Orders: orders@thinbit.com Quotes: quotes@thinbit.com

GENERAL INFORMATION

- HOURS:** Our business hours are:
Monday - Thursday: 7:30 am to 5:00 pm Eastern Standard Time.
Processing for same day shipment stops at 3:00 pm EST.
Friday: 7:30 am to 2:00 pm Eastern Standard Time
Processing for same day shipment stops at 12:00 pm EST.
- SHIPMENT:** Shipments are made by United Parcel Service. Ground service will be used (air for Alaska, Hawaii and U.S. Territories) unless otherwise specified by the customer. Shipments can be made via other carriers when customer provides shipping account number.
- TERMS:** Mastercard, Visa, Discover, American Express and C.O.D. accepted.
F.O.B. Fort Wayne, Indiana.
No minimum order on standard items.
We collect sales tax in California only.
- PRICING:** Current pricing is available online at: <http://www.thinbit.com/price> list.
Items cannot be combined for quantity prices.
A shipping and handling fee applies to all orders.
Prices for tooling modifications will be given in writing.
Pricing and availability on orders are confirmed to customer.
- RETURNS:** Returns are accepted for credit within 30 days of receipt of order and with prior written approval. All returns are subject to a 15% restocking charge. All returned goods must be in 'like-new' condition and returned in their original packaging.
All claims for damaged goods or incorrect items must be made within 48 hours of receipt of order.
- CREDIT:** 30 day net credit for approved accounts.
Accounts must re-establish credit after 18 months of inactivity.

OUTSIDE THE U.S.A.

- TERMS:** Cash in advance until credit is established. Payment via Mastercard, Visa, Discover, American Express, or bank to bank transfer in U.S. funds. F.O.B. Fort Wayne, Indiana, U.S.A.
Please notify us prior to remittance to confirm total amount including shipping charges.
Shipments made outside the U.S.A. are shipped via United Parcel Service.
Shipments can be made via other carriers when customer provides shipping account number.

Kaiser Tool Company, Inc. has made every effort to produce a catalog that is accurate and error free. Kaiser Tool Company, Inc. is not responsible for any loss due to errors or changes in product specifications. For the most accurate and up to date information, contact our sales office.

THINBIT®

PRODUCT INDEX

To use this index: Match the first few characters from your invoice or tool to the 'Product Code'.

Product Code	Description	Page	Product Code	Description	Page
AD	Round & Square Adapters	7-2	LGTF	GROOVE 'N TURN® Face Grooving Insert	2-10
AT	MICROBIT® ACME Threading Tool	4-6	LGTT	GROOVE 'N TURN® Threading Insert	4-10
BT	MICROBIT® Boring Tool	3-4	LHA	LITTLEBIT® Hardinge Toolholder	10-5
Clamp A	Clamp	10-5,6	LHDDR	GROOVE 'N TURN® Round Reversible Toolholder	7-7
Clamp C	Clamp	Section 7, 10	LPT	LITTLEBIT® Parting Insert	10-2
Clamp M	Clamp	7-9	LR	GROOVE 'N TURN® Round Angled Toolholders	7-13; 7-14
Clamp N	Clamp	7-9	LRE	LITTLEBIT® Reversible Toolholder	10-7
Clamp Q	Clamp	7-12	LREH	LITTLEBIT® Reversible Head	10-7
Clamp R	Clamp	7-12	LRI	LITTLEBIT® 90° Reversible Toolholder	10-7
Clamp X	Clamp	7-3,12	LRIH	LITTLEBIT® 90° Reversible Head	10-7
Clamp Y	Clamp	7-3,12	LRMAG	MILL A GROOVE® Trepanning	11-1;11-2
CN	Custom Made Tooling	Call	LR0	GROOVE 'N TURN® Round Internal Toolholder	7-8; 10-8
DGC	DEEPGROOVE® Clamp	1-8,14;2-8,16;7-15,16	LROE	GROOVE 'N TURN® Rnd Reversible Toolholder/Head	10-8
DGH	DEEPGROOVE® Head	1-14;2-8,16;7-15,16	LSET	LITTLEBIT® Grooving Insert Set	10-4
DGI	DEEPGROOVE® Insert	6-2	LSS	LITTLEBIT® Swiss Toolholder	7-12;10-6
DGMI	DEEPGROOVE® Insert	6-2	LSSFG	GROOVE 'N TURN® Swiss Face Groove Toolholder	7-6;10-6
DGPA	DEEPGROOVE® Tooling Package	2-16	LTT	LITTLEBIT® Threading Insert	10-3
DGPB	DEEPGROOVE® Tooling Package	2-16	MBA	MINI-BORE® Boring Bar	3-13
DGPC	DEEPGROOVE® Tooling Package	2-16	MBAI	MINI-BORE® Insert	3-14
DGPD	DEEPGROOVE® Tooling Package	2-16	MBB	MINI-BORE® Boring Bar	3-15
DGPE	DEEPGROOVE® Tooling Package	1-14	MBBI	MINI-BORE® Insert	3-16
DGPF	DEEPGROOVE® Tooling Package	1-14	MBC	MINI-BORE® Boring Bar	3-17
DGPG	DEEPGROOVE® Tooling Package	1-14	MBCI	MINI-BORE® Insert	3-18
DGPH	DEEPGROOVE® Tooling Package	1-14	MBE	MINI-BORE® TRIGON® Boring Bar	3-8
DGPM	DEEPGROOVE® Tooling Package	2-8	MBEI	MINI-BORE® TRIGON® Insert	3-8
DGPN	DEEPGROOVE® Tooling Package	2-8	MBF	MINI-BORE® TRIGON® Boring Bar	3-9
DGPO	DEEPGROOVE® Tooling Package	7-15	MBFI	MINI-BORE® TRIGON® Insert	3-9
DGPP	DEEPGROOVE® Tooling Package	7-15	MBG	MINI-BORE® TRIGON® Boring Bar	3-10
DGPQ	DEEPGROOVE® Tooling Package	7-15	MBGI	MINI-BORE® TRIGON® Insert	3-10
DGPR	DEEPGROOVE® Tooling Package	7-15	MBZ	MINI-BORE® Boring Bar	3-12
DGPS	DEEPGROOVE® Tooling Package	7-16	MBZI	MINI-BORE® Insert	3-12
DGPT	DEEPGROOVE® Tooling Package	7-16	MGC	Mini GROOVE 'N TURN® Clamp	1-6;2-6
DGPU	DEEPGROOVE® Tooling Package	7-16	MGT	Mini GROOVE 'N TURN® ID Toolholder	1-6
DGPV	DEEPGROOVE® Tooling Package	7-16	MGTF	Mini GROOVE 'N TURN® Face Grooving Toolholder	2-6
DGPZ	DEEPGROOVE® Tooling Package	1-8	MGTI	Mini GROOVE 'N TURN® Insert	1-5;2-5
DGS	DEEPGROOVE® Shank	1-14;2-8,16;7-15,16	MGTT	Mini GROOVE 'N TURN® Threading Insert	4-8
DGT	DEEPGROOVE® Shank	1-8	PT	MICROBIT® Profiling Tool	3-6
EM	FORM-A-GROOVE® Multi-Insert Toolholder	7-9	ROM	LITTLEBIT® Multi-Insert Toolholder Round	7-10
ESM	FORM-A-GROOVE® Multi-Insert Shank	7-9	RROE	GROOVE 'N TURN® Round Reversible Shank	10-8
FT	MICROBIT® Face Grooving Tool	2-4	RS	LITTLEBIT® Reversible Shank	10-7
GT	MICROBIT® Grooving Tool	1-4	RT	MICROBIT® Reverse Profiling Tool	3-6
HM	LITTLEBIT® Multi-Insert Pocket	7-9	S45	LITTLEBIT® 45° Toolholder	10-9
L30	GROOVE 'N TURN® Angled Toolholder	7 -11;7-12;7-13;7-14	SFT	LITTLEBIT® Flushtop Toolholder	10-5
L36	GROOVE 'N TURN® Angled Toolholder	7 -11;7-12;7-13;7-14	SGB	LITTLEBIT® Insert Blank	10-4
L45	GROOVE 'N TURN® Angled Toolholder	7 -11;7-12;7-13;7-14	SGI	LITTLEBIT® Grooving Insert	10-1
LFT	LITTLEBIT® Flushtop Toolholder	10-5	SGP	LITTLEBIT® Parting Insert Blank	10-4
LGAT	GROOVE 'N TURN® ACME Threading Insert	4-12	SHA	LITTLEBIT® Hardinge Toolholder	10-5
LGB	LITTLEBIT® Insert Blank	10-4	SPT	LITTLEBIT® Parting Insert	10-2
LGDT	GROOVE 'N TURN® Dovetail Face Grooving Insert	2-12	SRE	LITTLEBIT® Reversible Toolholder	10-7
LGI	LITTLEBIT® Grooving Insert	10-1	SREH	LITTLEBIT® Reversible Head	10-7
LGOR	GROOVE 'N TURN® Static O-Ring OD Insert	1-12	SRI	LITTLEBIT® 90° Reversible Toolholder	10-7
LGORF	GROOVE 'N TURN® Static O-Ring Face Insert	2-14	SRIH	LITTLEBIT® 90° Reversible Head	10-7
LGP	LITTLEBIT® Parting Insert Blank	10-4	SR0	LITTLEBIT® Round Internal Toolholder	10-8
LGPT	GROOVE 'N TURN® Parting Insert	5-4	SROE	LITTLEBIT® Round Reversible Toolholder/Head	10-8
LGS	GROOVE 'N TURN® OD Toolholder	7-3	SSET	LITTLEBIT® Grooving Insert Set	10-4
LGSF	GROOVE 'N TURN® Face Grooving Toolholder	7-4	SSS	LITTLEBIT® Swiss Toolholder	10-6
LGT45	GROOVE 'N TURN® Chamfering Insert	4-14	SSSFG	LITTLEBIT® Swiss Face Groove Toolholder	10-6
LGT	GROOVE 'N TURN® Grooving Insert	1-10; 2-10	STT	LITTLEBIT® Threading Insert	10-3
			TT	MICROBIT® Threading Tool	4-4

DISCONTINUED PRODUCT INDEX

PLEASE NOTE:

The following products have been discontinued from our standard catalog. Stock delivery is limited to quantity on hand at time of order. For out of stock products, delivery will be determined at time of order.

Please call for any products on the discontinued list below. We may be able to substitute or design a special application.

To use this index: Match the first few characters from your invoice or tool to the '**Product Code**'

Product Code	Description	Product Code	Description
Clamp B	Clamp	MBBSQ	MINI-BORE ® Boring Bar
Clamp D	Clamp	MBCSQ	MINI-BORE ® Boring Bar
Clamp E	Clamp	MBCH4	MINI-BORE ® Boring Bar
Clamp G	Clamp	MBCS4	MINI-BORE ® Boring Bar
Clamp H	Clamp	MBP	MINI-BORE ® Coolant Adapter
Clamp I	Clamp	MMA	MINI-BORE ® Boring Bar
Clamp J	Clamp	MMB	MINI-BORE ® Boring Bar
Clamp L	Clamp	MSET	Mini GROOVE 'N TURN ® Insert Set
Clamp O	Clamp	SFG	LITTLEBIT ® Face Grooving Insert
Clamp P	Clamp	SME	MINIBIT ® External Toolholder
Clamp S	Clamp	SMF	MINIBIT ® Face Grooving Toolholder
Clamp T	Clamp	SMGI	MINIBIT ® Grooving Insert
EM34	LITTLEBIT ® Multi-Insert Toolholder	SMI	MINIBIT ® Internal Toolholder
ESM34	LITTLEBIT ® Multi-Insert Shank	SMSET	MINIBIT ® Insert Sets
GTSET	GROOVE 'N TURN ® Insert Set	SMSF	MINIBIT ® Shoulder Face Grooving Insert
HM34	LITTLEBIT ® Multi-Insert Pocket	SMSG	MINIBIT ® Shoulder Grooving Insert
LFG	LITTLEBIT ® Face Grooving Insert	SMTT	MINIBIT ® Threading Insert
LME	MINIBIT ® External Toolholder	SSF	LITTLEBIT ® Face Grooving Insert
LMF	MINIBIT ® Face Grooving Toolholder	SSG	LITTLEBIT ® Grooving Insert
LMGI	MINIBIT ® Grooving Insert	XFG	LITTLEBIT ® Face Grooving Insert
LMI	MINIBIT ® Internal Toolholder	XGB	LITTLEBIT ® Insert Blank
LMSET	MINIBIT ® Insert Sets	XGI	LITTLEBIT ® Grooving Insert
LMSF	MINIBIT ® Face Grooving Insert	XRE	LITTLEBIT ® Reversible Toolholder
LMSG	MINIBIT ® Shoulder Grooving Insert	XREH	LITTLEBIT ® Reversible Head
LMTT	MINIBIT ® Threading Insert	XRI	LITTLEBIT ® 90° Reversible Toolholder
LSF	LITTLEBIT ® Shoulder Face Grooving Insert	XRIH	LITTLEBIT ® 90° Reversible Head
LSG	LITTLEBIT ® Shoulder Grooving Insert	XR0	LITTLEBIT ® Round Internal Toolholder
MBBH4	MINI-BORE ® Boring Bar	XSET	LITTLEBIT ® Grooving Insert Set
MBBS4	MINI-BORE ® Boring Bar		









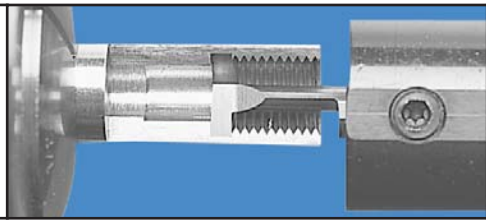

OVER 100,000 TOOLS IN STOCK FOR
GROOVING • THREADING • PARTING
BORING • TURNING • FACE GROOVING
SPECIALS • FORM TOOLS • MILLING

KAISER TOOL COMPANY, INC.

Phone: 888-THINBIT (888-844-6248) or (260) 484-3620
www.thinbit.com • Orders: orders@thinbit.com • Quotes: quotes@thinbit.com

PRODUCT SELECTION GUIDE - GROOVING

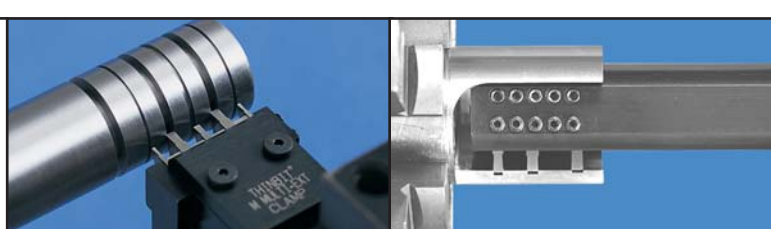
GROOVING

PAGE 1-3		<ul style="list-style-type: none"> • For internal diameters of .125" and larger • Groove widths .004"-.250" • For depth of cut up to .150" • Solid carbide shanks in 1/8", 3/16", 1/4", 5/16", 3/8" and 1/2" diameter
PAGE 1-5		<ul style="list-style-type: none"> • For internal diameters of .325" and larger • Groove widths .004"-.125" • For depth of cut up to .125" • Inserts can groove, bore and generate profiles • Inserts can also be used for face grooving
PAGE 1-7		<ul style="list-style-type: none"> • For internal diameters of 1" and larger • Groove widths 2, 3 and 4mm • For depth of cut up to .500"
PAGE 1-9		<ul style="list-style-type: none"> • Groove widths .004"-.150" • For depth of cut 2-1/2 to 3 times width • Inserts can groove, turn, generate profiles and be used for face grooving over 3" diameters • Carbide and High Speed Steel
PAGE 1-11		<ul style="list-style-type: none"> • Groove widths .095", .125" & .142" • Included Angle 7° • Two grades of Sub-Micron Grain Carbide
PAGE 1-13		<ul style="list-style-type: none"> • Groove widths 2, 3, 4, 5 and 6mm • For depth of cut to 1" • Inserts can also be used for parting and face grooving
PAGE 8-7		 <p>Used for generating multiple groove forms simultaneously</p>

KAISER TOOL COMPANY, INC.

Phone: 888-THINBIT (888-844-6248) or (260) 484-3620
 www.thinbit.com • Orders: orders@thinbit.com • Quotes: quotes@thinbit.com

TOOLING ORIENTATION GUIDE - GROOVING

GROOVING

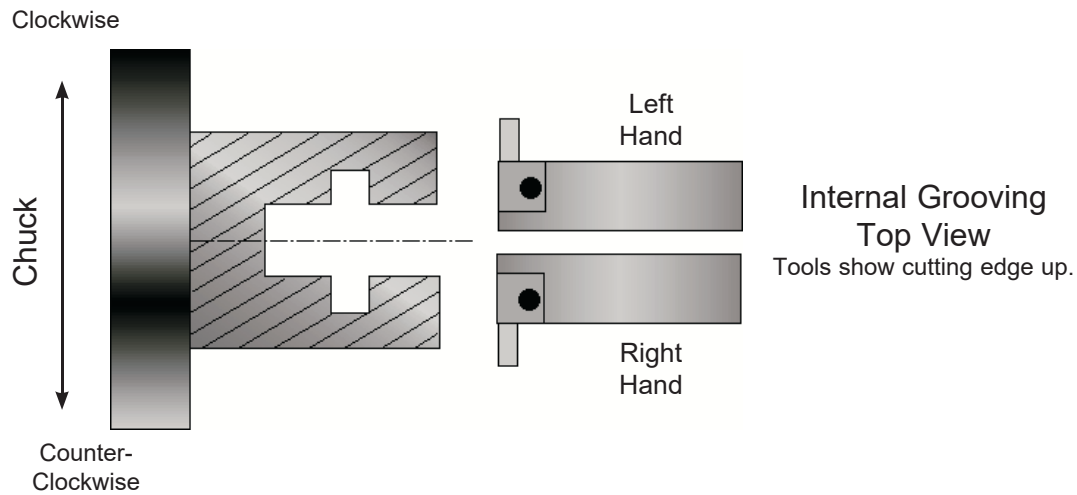
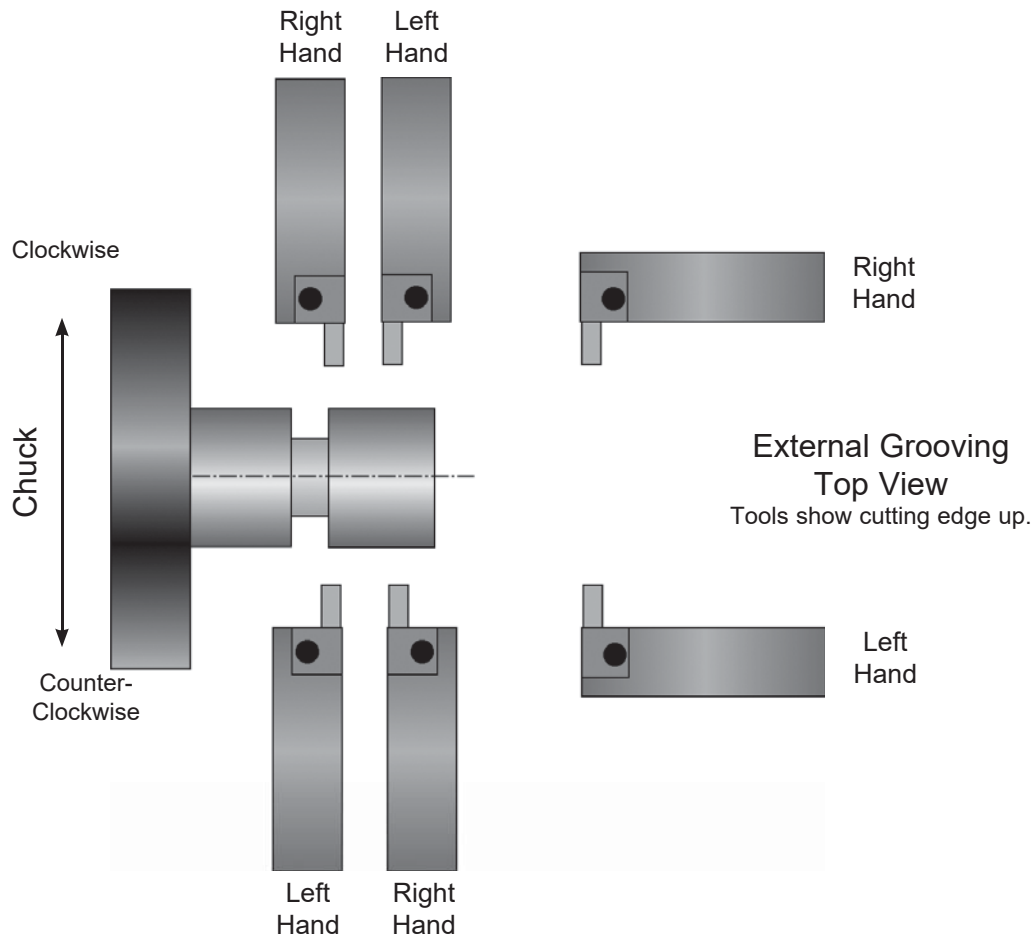

KAISER TOOL COMPANY, INC.

Phone: 888-THINBIT (888-844-6248) or (260) 484-3620
www.thinbit.com • Orders: orders@thinbit.com • Quotes: quotes@thinbit.com

MICROBIT®

PRODUCT INFORMATION

- Internal grooving for diameters .125" and larger.
- .004" through .250" groove widths in .001" increments.
- 1/8", 3/16", 1/4", 5/16", 3/8" and 1/2" shanks.
- Sub-micron grain **DURA-MAX® 2000** Carbide.
- Tools available with TiN, TiAlN, TiCN and diamond coating.
- Short neck lengths for greater rigidity; long neck lengths for greater reach.
- Elliptically ground necks for greater strength.

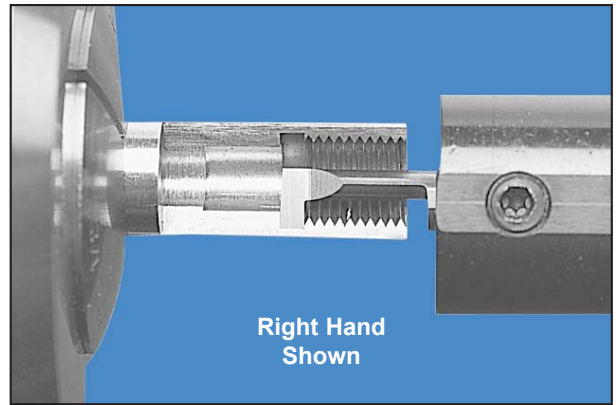

MODIFICATIONS

SEE PAGE
8-3
FOR ADDITIONAL
INFORMATION

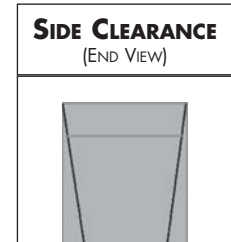
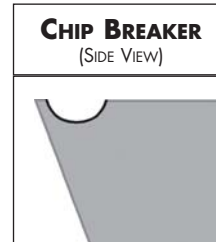
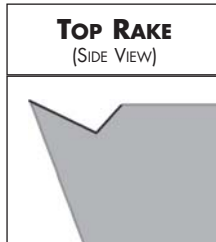
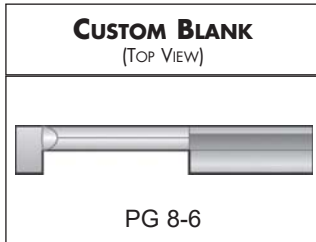
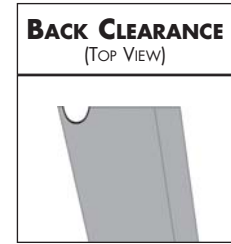
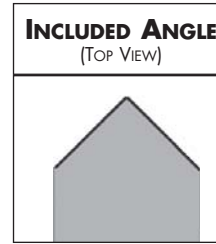
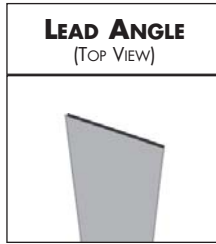
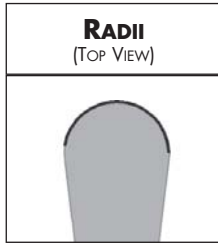

TOOLHOLDER SELECTIONS

ADAPTER STYLES

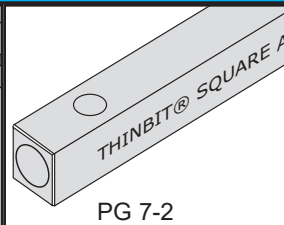
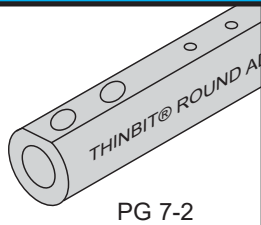

TECHNICAL SECTIONS

SPEEDS AND FEEDS

PG 9-10

APPLICATION REFERENCE

PG 9-4

TROUBLESHOOTING

PG 9-7

KAISER TOOL COMPANY, INC.

Phone: 888-THINBIT (888-844-6248) or (260) 484-3620
www.thinbit.com • Orders: orders@thinbit.com • Quotes: quotes@thinbit.com

I.D. GROOVING TOOLS

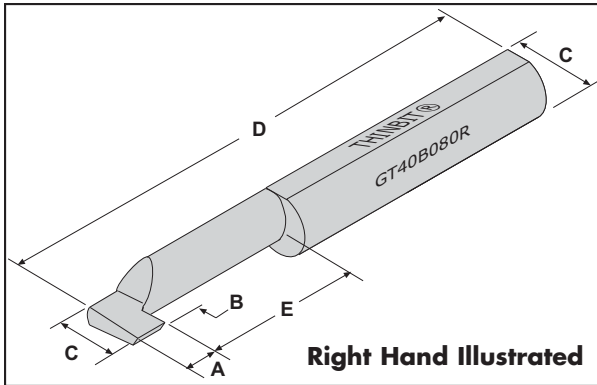

FRONT RAKE: Primary 21°
 BACK CLEARANCE: 2°
 SIDE CLEARANCE: 2°
 RADIUS: Sharp corner through full radius available
 TOP RAKE: 0°
 LEAD ANGLE: 0°
 'A' TOLERANCE: .004" - .250": +.0009"/-.0000"

I.D. GROOVING

ORDERING INSTRUCTIONS

Complete the **ORDER CODE** in the table below that represents your selection of groove width and tool dimensions.

EXAMPLE:

The **ORDER CODE** for a 1/4" shank, right hand tool with an .080" tool width, .110" depth of cut and .500" long neck is:

GT40B 0 8 0 R

Specify the Tool Width 'A' ↑

SPECIFICATIONS				ORDER CODE				INFORMATION											
Minimum Bore & Shank Diameter 'C'	Tool Width Range 'A'	Depth of Cut 'B'	Neck Length 'E'	DURA-MAX® 2000 Carbide See Page 9-10 for speeds and feeds		Add-ons Use 'Order Code' and Add			Overall Length 'D'	Toolholder Page 7-2 Use Toolholders Beginning With									
				Right Hand	Left Hand	Full Radius Page 8-3	Corner Radius Page 8-3	Coating Page 9-6											
1/8"	.004"-.063"	.004"-.006" = 3 x 'A'	.250"	GT20C ___ R	GT20C ___ L	Maximum radius limited to depth of cut * See Note	add 'FR'	add 'CR___' (indicate size in .xxx") Maximum radius limited to depth of cut * See Note	TiN add 'C'	1.365" + 'A'	'AD'								
		.007"-.063" = .020"	.375"	GT21C ___ R	GT21C ___ L														
		.004"-.016" = 3 x 'A'	.250"	GT20B ___ R	GT20B ___ L														
		.017"-.063" = .050"	.375"	GT21B ___ R	GT21B ___ L														
3/16"	.004"-.093"	.004"-.011" = 3 x 'A'	.375"	GT30C ___ R	GT30C ___ L					Maximum radius limited to depth of cut * See Note	add 'FR'	TiN add 'C'	1.865" + 'A'	'AD'					
		.012"-.093" = .035"	.625"	GT31C ___ R	GT31C ___ L														
		.004"-.026" = 3 x 'A'	.375"	GT30B ___ R	GT30B ___ L														
		.027"-.093" = .080"	.625"	GT31B ___ R	GT31B ___ L														
1/4"	.004"-.125"	.004"-.016" = 3 x 'A'	.500"	GT40C ___ R	GT40C ___ L								Maximum radius limited to depth of cut * See Note	add 'FR'	TiCN add 'D'	2.365" + 'A'	'AD'		
		.017"-.125" = .050"	.750"	GT41C ___ R	GT41C ___ L														
		.004"-.036" = 3 x 'A'	.500"	GT40B ___ R	GT40B ___ L														
		.037"-.125" = .110"	.750"	GT41B ___ R	GT41B ___ L														
5/16"	.004"-.156"	.004"-.021" = 3 x 'A'	.625"	GT50C ___ R	GT50C ___ L	Maximum radius limited to depth of cut * See Note	add 'FR'	Diamond add 'F'	2.330" + 'A'							'AD'			
		.022"-.156" = .063"	1.000"	GT51C ___ R	GT51C ___ L														
		.004"-.046" = 3 x 'A'	.625"	GT50B ___ R	GT50B ___ L														
		.047"-.156" = .140"	1.000"	GT51B ___ R	GT51B ___ L														
3/8"	.004"-.187"	.004"-.036" = 3 x 'A'	.750"	GT60C ___ R	GT60C ___ L				Maximum radius limited to depth of cut * See Note	add 'FR'	Diamond add 'F'	2.800" + 'A'				'AD'			
		.037"-.187" = .110"	1.250"	GT61C ___ R	GT61C ___ L														
1/2"	.004"-.250"	.004"-.050" = 3 x 'A'	1.000"	GT80C ___ R	GT80C ___ L							Maximum radius limited to depth of cut * See Note				add 'FR'	Diamond add 'F'	3.240" + 'A'	'AD'
		.051"-.250" = .150"	1.750"	GT81C ___ R	GT81C ___ L														

* Example: GT31C093R - max radius would be .035"

KAISER TOOL COMPANY, INC.

Phone: 888-THINBIT (888-844-6248) or (260) 484-3620
 www.thinbit.com • Orders: orders@thinbit.com • Quotes: quotes@thinbit.com

PRODUCT INFORMATION

- Internal grooving and profiling for diameters .325" and larger.
- Shank sizes 1/4", 3/8", 1/2" and 5/8" in steel, heavy metal or carbide.
- All toolholders are reversible for right and left hand orientation.
- Sub-micron grain **DURA-MAX® 2000** and **5000** Carbides and High Speed Steel.
- Modifications can be provided on any of our tooling.
- Please contact us with your application requirements.



Left Hand Insert in
Right Hand Toolholder
Shown

TECHNICAL SECTIONS	SPEEDS AND FEEDS	APPLICATION REFERENCE	TROUBLESHOOTING
	PG 9-10	PG 9-4	PG 9-7

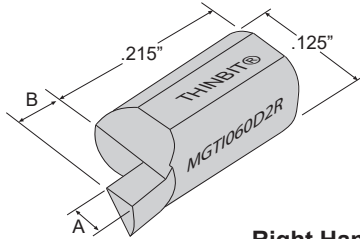

Right Hand Illustrated

FRONT RAKE: 15°
 BACK CLEARANCE: 2° both sides
 SIDE CLEARANCE: 2° I.D. side
 RADIUS: Sharp corner through
 full radius available
 TOP RAKE: 0°
 LEAD ANGLE: 0°
 'A' TOLERANCE:
 .004" - .063": +.0009"/-.0000"
 .064" - .125": +.001"/-.001"

SPECIFICATIONS			ORDER CODE				
Insert Orientation	Insert Width 'A'	Depth of Cut 'B'	Insert Grades <small>See Page 9-5 for expanded material descriptions and Page 9-10 or 9-12 for Speeds and Feeds information</small>		Add-ons <small>Use 'Order Code' and Add</small>		
			DURA-MAX® 2000 Carbide <small>For Steel & Interrupted Cutting</small>	DURA-MAX® 5000 Carbide <small>For Aluminum & Non-ferrous</small>	Full Radius Page 8-3	Corner Radius Page 8-3	Coating Page 9-6
Right Hand <small>For ID grooving use left hand 'MGT' Page 1-5</small> <small>For face grooving use right hand 'MGTF' Page 2-6</small>	.004"-.063"	<u>Width</u> <u>DOC</u> .004"-.031" = 2 x 'A' .032"-.063" = .063"	MGTI ___ _D2R	MGTI ___ _D5R	add 'FR'	(indicate size in .xxx")	TiN add 'C' TiCN add 'D' TiAlN add 'E' Diamond add 'F'
	.064"-.125"	<u>Width</u> <u>DOC</u> .064"-.083" = 1.5 x 'A' .084"-.125" = .125"					
Left Hand <small>For ID grooving use right hand 'MGT' Page 1-5</small> <small>For face grooving use left hand 'MGTF' Page 2-6</small>	.004"-.063"	<u>Width</u> <u>DOC</u> .004"-.031" = 2 x 'A' .032"-.063" = .063"	MGTI ___ _D2L	MGTI ___ _D5L			
	.064"-.125"	<u>Width</u> <u>DOC</u> .064"-.083" = 1.5 x 'A' .084"-.125" = .125"					

KAISER TOOL COMPANY, INC.

I.D. GROOVING TOOLS

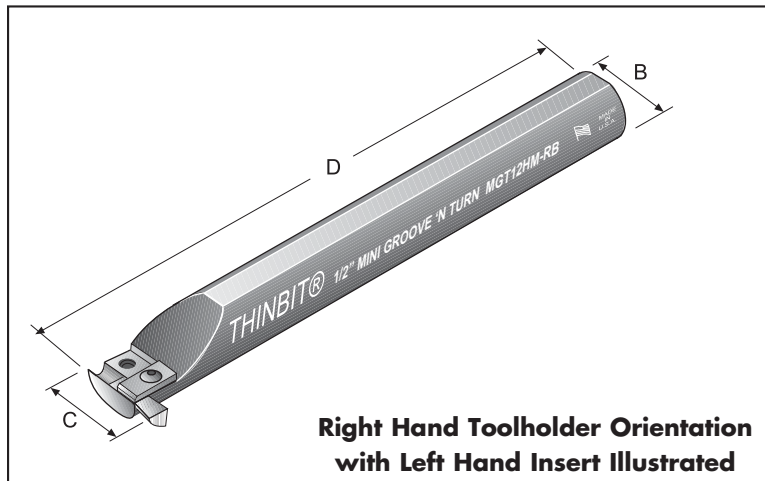

Note:

- All toolholders are reversible for right hand or left hand orientation.

- For grooving:

Insert Width	Depth of Cut
.004"-.031"	2 x width
.032"-.063"	.063"
.064"-.083"	1.5 x width
.084"-.125"	.125"

I.D.
GROOVING

ORDERING INSTRUCTIONS

Select the **ORDER CODE** in the table below that represents your selection of tool specifications.

EXAMPLE:

The **ORDER CODE** for a .575" minimum bore toolholder with a 1/2" steel shank is:

MGT12

SPECIFICATIONS		ORDER CODE				INFORMATION		
Minimum Bore 'C'	Toolholder Material Extension Ratios: Steel: 4x Heavy Metal: 6x Carbide: 8x	Toolholder Package Includes Shank, Clamp and Hardware	Replacement Parts Clamp Only Screw Only Wrench Only			Overall Length 'D'	Shank Diameter 'B'	Inserts Use Inserts Beginning With
.325" .063" Insert Width Maximum (Threading & Groove Widths .004"-.063")	Steel	MGT14	MGC1	F31	W31	4.000"	1/4"	Grooving: 'MGT1' Page 1-5 Threading: 'MGTT' Page 4-8 Use right hand inserts for clockwise or left hand inserts for counter-clockwise
	Heavy Metal	MGT14HM				3.965"		
	Carbide	MGT14C				6.504"		
.450" .063" Insert Width Maximum (Threading & Groove Widths .004"-.063")	Steel	MGT38	MGC1	F31	W31	5.500"	3/8"	
	Heavy Metal	MGT38HM				5.485"		
	Carbide	MGT38C				6.768"		
.575" (Threading & Groove Widths .004"-.063") or .640" (Groove Widths .064"-.125")	Steel	MGT12	MGC1	F31	W31	5.500"	1/2"	
	Heavy Metal	MGT12HM				5.485"		
.690" (Threading & Groove Widths .004"-.063") or .755" (Groove Widths .064"-.125")	Steel	MGT58	MGC1	F31	W31	5.500"	5/8"	

KAISER TOOL COMPANY, INC.

Phone: 888-THINBIT (888-844-6248) or (260) 484-3620
www.thinbit.com • Orders: orders@thinbit.com • Quotes: quotes@thinbit.com

PRODUCT INFORMATION

- Internal grooving for diameters 1" and larger.
- 3/4" and 1" shank diameters.
- Right hand orientation standard.
- Short neck lengths for greater rigidity; long neck lengths for greater reach.
- Elliptical neck for increased strength and rigidity.
- Modifications can be provided on any of our tooling. Please contact us with your application requirements.

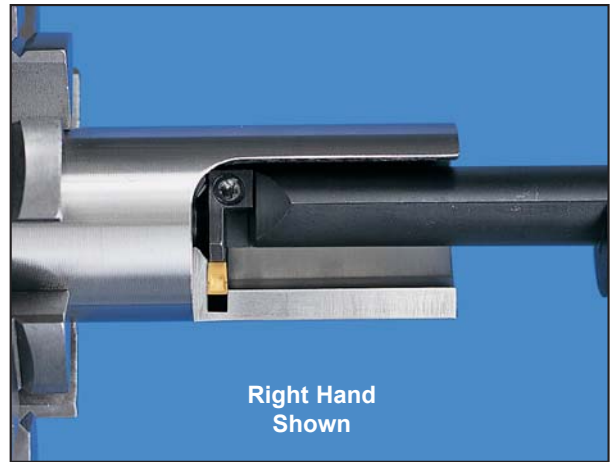

INSERT SELECTIONS

SEE PAGE 6-1

INSERT STYLES

CORNER RADIUS (TOP VIEW)



SHARP CORNER (TOP VIEW)



TECHNICAL SECTIONS

SPEEDS AND FEEDS

PG 9-10

APPLICATION REFERENCE

PG 9-4

TROUBLESHOOTING

PG 9-7

KAISER TOOL COMPANY, INC.

Phone: 888-THINBIT (888-844-6248) or (260) 484-3620
www.thinbit.com • Orders: orders@thinbit.com • Quotes: quotes@thinbit.com

I.D. GROOVING TOOLS

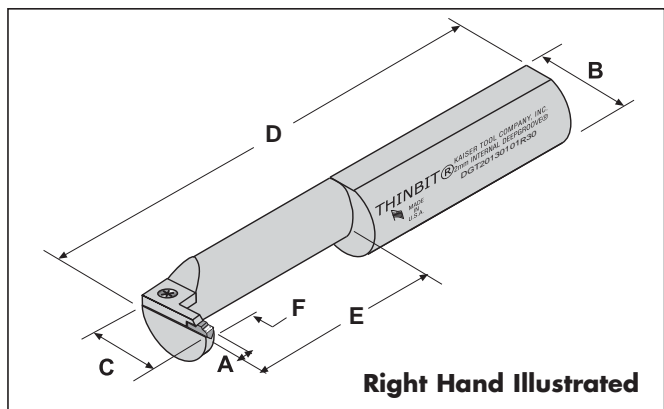

ORDERING INSTRUCTIONS

Select the **ORDER CODE** in the table below that represents your selection of tool specifications.

EXAMPLE:

The **ORDER CODE** for a 2mm insert width toolholder package with a depth of cut of .500", a 1" shank and a 3" neck is: **DGPZ2013010130**

SPECIFICATIONS					ORDER CODE						INFO.					
Minimum Bore	Insert Width	Depth of Cut	Neck Length	Shank Diameter	Toolholder Package Includes Shank, Clamp and Hardware	Inserts	Replacement Parts				Overall Length					
'C'	'A'	'F'	'E'	'B'	Right Hand	Use Inserts Beginning With	Shank	Clamp	Screw	Wrench	'D'					
1"	2mm (.078")	.393"	1.5"	3/4"	DGPZ2010013415	'DGI2' (Page 6-2)	DGT20100134R15	DGC82013	S4552	W3200	5.5"					
				1"	DGPZ2010010115		DGT20100101R15									
			3"	3/4"	DGPZ2010013430		DGT20100134R30					7"				
		1"	DGPZ2010010130	DGT20100101R30												
		.500"	1.5"	3/4"	DGPZ2013013415		DGT20130134R15						5.5"			
				1"	DGPZ2013010115		DGT20130101R15									
	3"		3/4"	DGPZ2013013430	DGT20130134R30		7"									
	1"	DGPZ2013010130	DGT20130101R30													
	1"	3mm (.118")	.393"	1.5"	3/4"		DGPZ3010013415				'DGM13' (Page 6-2)	DGT30100134R15	DGC83013	S4552	W3200	5.5"
					1"		DGPZ3010010115					DGT30100101R15				
				3"	3/4"		DGPZ3010013430					DGT30100134R30				
			1"	DGPZ3010010130	DGT30100101R30											
.500"			1.5"	3/4"	DGPZ3013013415	DGT30130134R15	5.5"									
				1"	DGPZ3013010115	DGT30130101R15										
		3"	3/4"	DGPZ3013013430	DGT30130134R30	7"										
1"		DGPZ3013010130	DGT30130101R30													
1"		4mm (.157")	.393"	1.5"	3/4"	DGPZ4010013415	'DGM14' (Page 6-2)	DGT40100134R15	DGC84013	S4552		W3200				5.5"
					1"	DGPZ4010010115		DGT40100101R15								
				3"	3/4"	DGPZ4010013430		DGT40100134R30								
			1"	DGPZ4010010130	DGT40100101R30											
	.500"		1.5"	3/4"	DGPZ4013013415	DGT40130134R15		5.5"								
				1"	DGPZ4013010115	DGT40130101R15										
		3"	3/4"	DGPZ4013013430	DGT40130134R30	7"										
	1"	DGPZ4013010130	DGT40130101R30													

KAISER TOOL COMPANY, INC.

PRODUCT INFORMATION

- External grooving and turning.
- Internal grooving and boring with 1.250" minimum bore diameter.
- .004" through .150" in .001" increments available.
- Sub-micron grain **DURA-MAX® 2000** and **5000** Carbides and High Speed Steel.
- Inserts available with TiN, TiAlN, TiCN and Diamond coating.

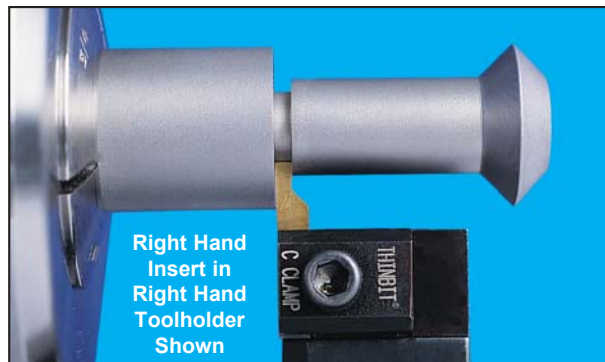

MODIFICATIONS

SEE PAGE 8-3 FOR ADDITIONAL INFORMATION

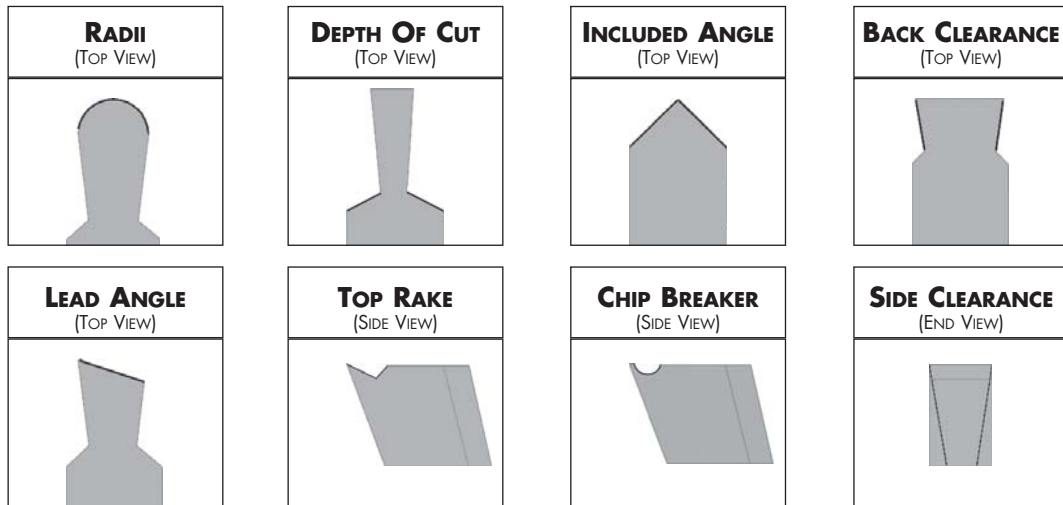

TOOLHOLDER SELECTIONS

CNC, SWISS, CONVENTIONAL STYLE

ROUND STYLE

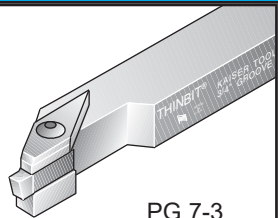

PG 7-3

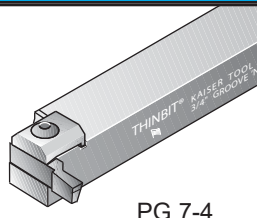

PG 7-4

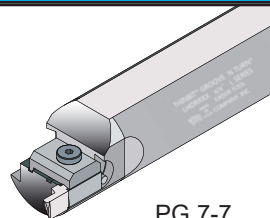

PG 7-7

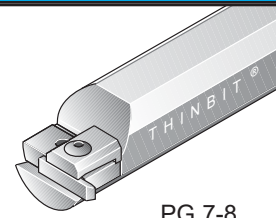

PG 7-8

TECHNICAL SECTIONS

SPEEDS AND FEEDS

APPLICATION REFERENCE

TROUBLESHOOTING

PG 9-10

PG 9-3

PG 9-7

KAISER TOOL COMPANY, INC.

Phone: 888-THINBIT (888-844-6248) or (260) 484-3620
www.thinbit.com • Orders: orders@thinbit.com • Quotes: quotes@thinbit.com

O.D./I.D. GROOVING AND TURNING INSERTS

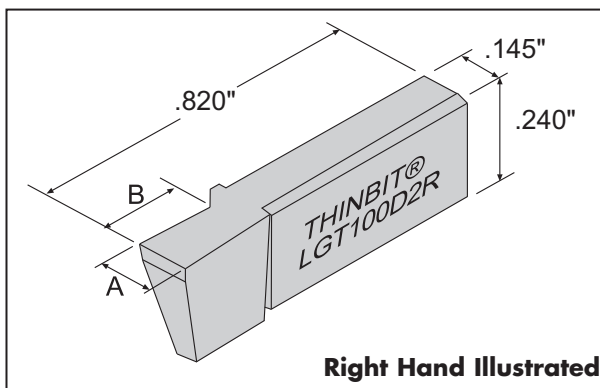

Right Hand Illustrated

FRONT RAKE:

CARBIDE: Primary 10° honed, Secondary 15°
HIGH SPEED STEEL: 15°

BACK CLEARANCE: 2-1/2° both sides

SIDE CLEARANCE: .004" - .019" - 0° both sides
.020" - .150" - 5° both sides

RADIUS: Sharp corner through full radius available

TOP RAKE: 0°

LEAD ANGLE: 0°

NOTES: Capable of grooving along a shoulder
.004"-.019" inserts are not designed for turning

O.D. & I.D.
GROOVING

ORDERING INSTRUCTIONS

Complete the **ORDER CODE** in the table below that represents your selection of groove width and insert grade.

EXAMPLE:

The **ORDER CODE** for a right hand, .100" insert width in **DURA-MAX® 2000** is:

LGT 1 0 0 D 2 R

Specify the Tool Width 'A' _____ ↑

SPECIFICATIONS			ORDER CODE					INFO.	
Insert Orientation	Insert Width 'A' +.0009"/-.0000"	Depth of Cut 'B' <u>Width</u> <u>DOC</u> .004"-.033" = 3 x 'A' .034"-.039" = .100" .040"-.100" = 2.5 x 'A' .101"-.150" = .250"	Insert Grades <small>See Page 9-5 for expanded material descriptions and Page 9-10 for Speeds and Feeds information</small>			Add-ons <small>Use 'Order Code' and Add</small>			Toolholder Catalog Section 7 Use Toolholders Beginning With
			DURA-MAX® 2000 Carbide <small>For Steel & Interrupted Cutting</small>	DURA-MAX® 5000 Carbide <small>For Aluminum & Non-ferrous</small>	High Speed Steel	Full Radius Page 8-3	Corner Radius Page 8-3	Coating Page 9-6	
Right Hand	.004"-.150"		LGT ___ D2R	LGT ___ D5R	LGT ___ HSR	add 'FR'	add 'CR___' <small>(indicate size in .xxx")</small>	TiN add 'C' TiCN add 'D'	'L' Use right hand straight holder or left hand 90° holder
Left Hand	.004"-.150"		LGT ___ D2L	LGT ___ D5L	LGT ___ HSL	add 'FR'	add 'CR___' <small>(indicate size in .xxx")</small>	TiAIN add 'E' Diamond add 'F'	'L' Use left hand straight holder or right hand 90° holder

KAISER TOOL COMPANY, INC.

Phone: 888-THINBIT (888-844-6248) or (260) 484-3620
www.thinbit.com • Orders: orders@thinbit.com • Quotes: quotes@thinbit.com

GROOVE 'N TURN® INSERTS

U.S. PATENT NOS. 6,688,816 and 6,824,333

PRODUCT INFORMATION

- External grooving.
- Internal Static O-Ring grooving with 1.250" minimum bore diameter.
- Sub-micron grain **DURA-MAX® 2000** and **5000** Carbides.
- Inserts available with TiN, TiAlN, TiCN and Diamond coating.

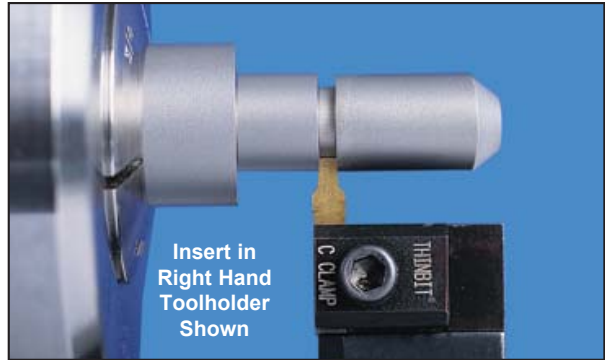

MODIFICATIONS

SEE PAGE 8-3 FOR ADDITIONAL INFORMATION

RADI (TOP VIEW)	DEPTH OF CUT (TOP VIEW)	INCLUDED ANGLE (TOP VIEW)	BACK CLEARANCE (TOP VIEW)
LEAD ANGLE (TOP VIEW)	TOP RAKE (SIDE VIEW)	CHIP BREAKER (SIDE VIEW)	SIDE CLEARANCE (END VIEW)

TOOLHOLDER SELECTIONS

CNC, SWISS, CONVENTIONAL STYLE

ROUND STYLE

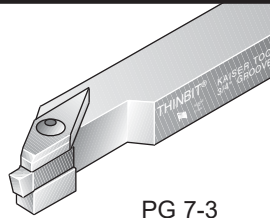

PG 7-3

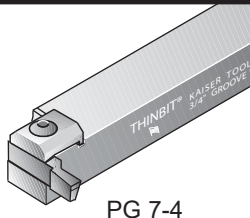

PG 7-4

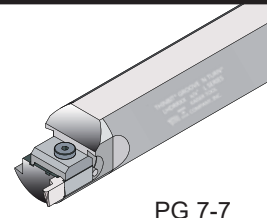

PG 7-7

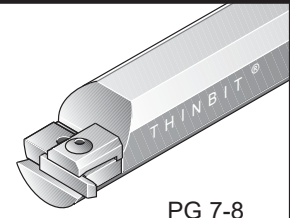

PG 7-8

TECHNICAL SECTIONS

SPEEDS AND FEEDS

PG 9-10

APPLICATION REFERENCE

PG 9-3

TROUBLESHOOTING

PG 9-7

KAISER TOOL COMPANY, INC.

Phone: 888-THINBIT (888-844-6248) or (260) 484-3620
 www.thinbit.com • Orders: orders@thinbit.com • Quotes: quotes@thinbit.com

O.D. STATIC O-RING INSERTS

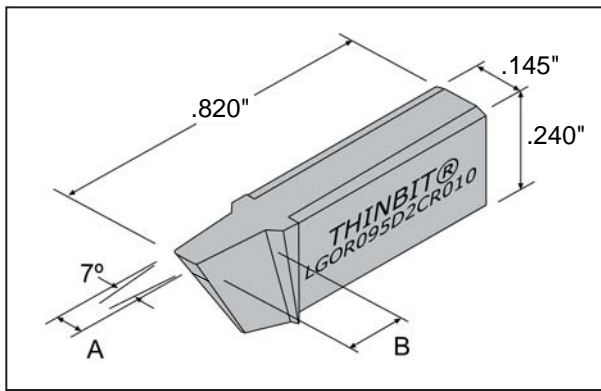

FRONT RAKE: Primary 10° honed, Secondary 15°
 BACK CLEARANCE: 7° included angle
 SIDE CLEARANCE: 5° both sides
 RADIUS: .010" or .020"
 TOP RAKE: 0°
 LEAD ANGLE: 0°
 DEPTH OF CUT: .200" or .250"

STATIC O-RING
GROOVING

ORDERING INSTRUCTIONS

Select the **ORDER CODE** in the table below that represents your selection of groove width and insert grade.

EXAMPLE:

The **ORDER CODE** for a .095" insert width in **DURA-MAX® 2000** is:

LGOR095D2CR010

SPECIFICATIONS			ORDER CODE		INFO.	
Insert Orientation & Radius	Insert Width	Depth of Cut	Insert Grades See Page 9-5 for expanded material descriptions and Page 9-10 for Speeds and Feeds information		Add-ons Use 'Order Code' and Add	Toolholder Catalog Section 7 Use Toolholders Beginning With
	'A' ± .001"	'B'	DURA-MAX® 2000 Carbide For Steel & Interrupted Cutting	DURA-MAX® 5000 Carbide For Aluminum & Non-ferrous	Coating Page 9-6	
Centered .010" Corner Radius	.095"	.250"	LGOR095D2CR010	LGOR095D5CR010	TiN add 'C'	'L'
	.142"	.200"	LGOR142D2CR010	LGOR142D5CR010	TiCN add 'D' TiAlN add 'E'	
Centered .020" Corner Radius	.125"	.250"	LGOR125D2CR020	LGOR125D5CR020	Diamond add 'F'	

KAISER TOOL COMPANY, INC.

Phone: 888-THINBIT (888-844-6248) or (260) 484-3620
 www.thinbit.com • Orders: orders@thinbit.com • Quotes: quotes@thinbit.com

PRODUCT INFORMATION

- External grooving and parting with depth of cut to 1".
- Shank sizes 3/4", 1", 16mm, 20mm and 25mm in straight and 90° orientations.
- Modular tooling system will also accept face grooving heads. See compatibility guide on Page 9-8.
- If round shanks are required, see Page 7-13, Package Styles 'Q' and 'R'.
- Modifications can be provided on any of our tooling. Please contact us with your application requirements.



INSERT SELECTIONS

SEE PAGE 6-1

INSERT STYLES

CORNER RADIUS (TOP VIEW)



SHARP CORNER (TOP VIEW)



TECHNICAL SECTIONS

SPEEDS AND FEEDS

PG 9-10

APPLICATION REFERENCE

PG 9-3

TROUBLESHOOTING

PG 9-7

PACKAGE STYLE

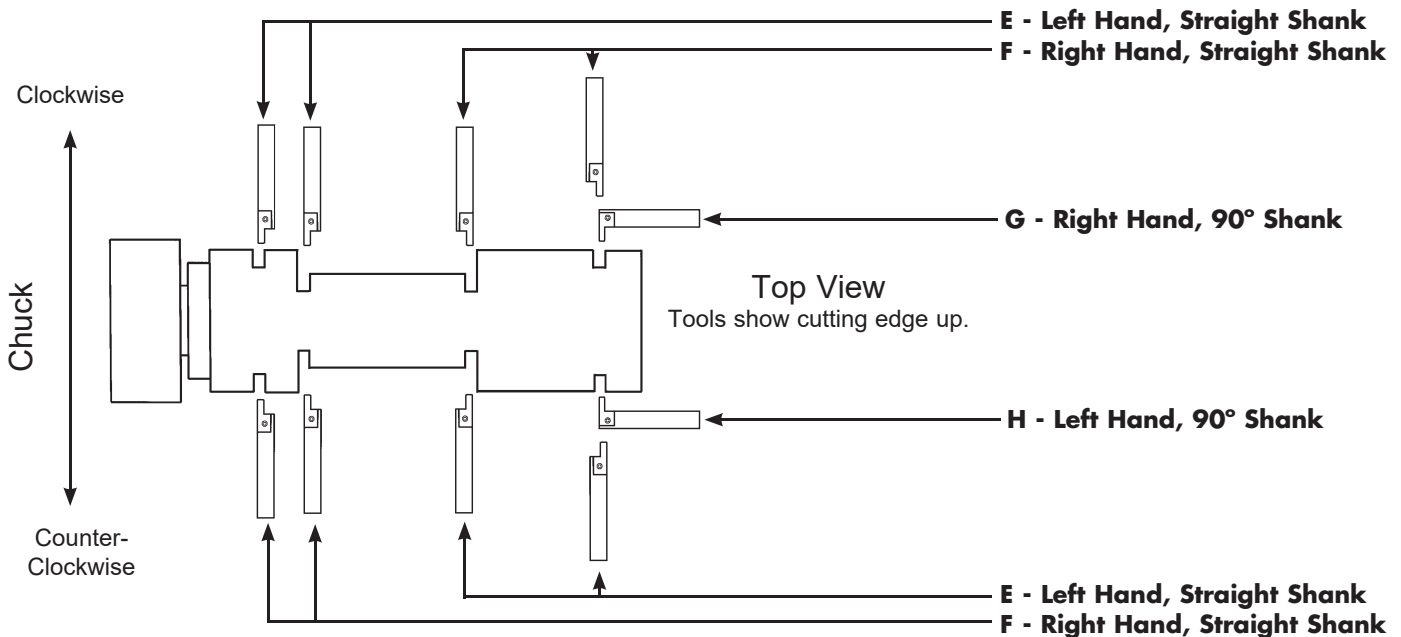

Note: If round shanks are required, see Page 7-13, Package Styles 'Q' and 'R'.

KAISER TOOL COMPANY, INC.

Phone: 888-THINBIT (888-844-6248) or (260) 484-3620
www.thinbit.com • Orders: orders@thinbit.com • Quotes: quotes@thinbit.com

O.D. GROOVING AND PARTING TOOLS

ORDERING INSTRUCTIONS

3/4" and 1" Shanks

Select the **ORDER CODE** in the table below that represents your selection of tool specifications.

EXAMPLE:

The **ORDER CODE** for a 3mm insert width, toolholder package style 'E' with a .500" depth of cut and 1" shank is:

DGPE301301

Metric Shanks

Complete the **ORDER CODE** in the table below with the shank size as 16 (16mm), 20 (20mm) or 25 (25mm).

EXAMPLE:

The **ORDER CODE** for a 3mm insert width, toolholder package style 'E' with a .500" depth of cut and 20mm shank is:

DGPE3013 20 ← Specify the 'SHANK SIZE'

O.D. GROOVING & PARTING





SPECIFICATIONS			ORDER CODE										
Insert Width	Depth of Cut	Package Style See Page 1-13	Toolholder Package <small>Includes Shank, Head, Clamp and Hardware</small>			Inserts Use Inserts Beginning With	Head	Replacement Parts					
			3/4" Shank <small>3/4"x3/4"x5"</small>	1" Shank <small>1"x1"x5"</small>	Metric Shanks <small>16 = 16x16x125mm 20 = 20x1"x125mm 25 = 25x1"x125mm</small>			Head Hardware	Shank <small>34 = 3/4" 01 = 1" 16 = 16mm 20 = 20mm 25 = 25mm</small>	Clamp	Clamp Hardware		
2mm (.078")	13mm (1/2")	E	DGPE201334	DGPE201301	DGPE2013 __	'DGI2' (Page 6-1)	DGH22013	Screw: 2 each S7552	DGS__XL	DGC22013	Screw: S6552		
		G	DGPG201334	DGPG201301	DGPG2013 __		DGH12013		DGS__YR	DGC12013			
		F	DGPF201334	DGPF201301	DGPF2013 __				DGS__XR				
		H	DGPH201334	DGPH201301	DGPH2013 __				DGS__YL				
3mm (.118")	13mm (1/2")	E	DGPE301334	DGPE301301	DGPE3013 __	'DGI3' (Page 6-1)	DGH23013			DGS__XL		DGC23013	
		G	DGPG301334	DGPG301301	DGPG3013 __		DGH13013		DGS__YR	DGC13013			
		F	DGPF301334	DGPF301301	DGPF3013 __				DGS__XR				
		H	DGPH301334	DGPH301301	DGPH3013 __				DGS__YL				
4mm (.157")	13mm (1/2")	E	DGPE401334	DGPE401301	DGPE4013 __	'DGI4' (Page 6-1)	DGH24013			DGS__XL		DGC24013	
		G	DGPG401334	DGPG401301	DGPG4013 __		DGH14013		DGS__YR	DGC14013			
		F	DGPF401334	DGPF401301	DGPF4013 __				DGS__XR				
		H	DGPH401334	DGPH401301	DGPH4013 __				DGS__YL				
	20mm (3/4")	E	DGPE402034	DGPE402001	DGPE4020 __		DGH24020		DGS__XL	DGC24020			
		G	DGPG402034	DGPG402001	DGPG4020 __		DGH14020		DGS__YR	DGC14020			
		F	DGPF402034	DGPF402001	DGPF4020 __				DGS__XR				
		H	DGPH402034	DGPH402001	DGPH4020 __				DGS__YL				
5mm (.197")	13mm (1/2")	E	DGPE501334	DGPE501301	DGPE5013 __	'DGI5' (Page 6-1)	DGH25013	Wrench: W4025	DGS__XL	DGC25013	Wrench: W4025		
		G	DGPG501334	DGPG501301	DGPG5013 __		DGH15013		DGS__YR	DGC15013			
		F	DGPF501334	DGPF501301	DGPF5013 __				DGS__XR				
		H	DGPH501334	DGPH501301	DGPH5013 __				DGS__YL				
	25mm (1")	E	DGPE502534	DGPE502501	DGPE5025 __		DGH25025			DGS__XL		DGC25025	
		G	DGPG502534	DGPG502501	DGPG5025 __		DGH15025			DGS__YR		DGC15025	
		F	DGPF502534	DGPF502501	DGPF5025 __					DGS__XR			
		H	DGPH502534	DGPH502501	DGPH5025 __					DGS__YL			
6mm (.236")	13mm (1/2")	E	DGPE601334	DGPE601301	DGPE6013 __	'DGI6' (Page 6-1)	DGH26013			DGS__XL		DGC26013	
		G	DGPG601334	DGPG601301	DGPG6013 __		DGH16013		DGS__YR	DGC16013			
		F	DGPF601334	DGPF601301	DGPF6013 __				DGS__XR				
		H	DGPH601334	DGPH601301	DGPH6013 __				DGS__YL				
	25mm (1")	E	DGPE602534	DGPE602501	DGPE6025 __		DGH26025		DGS__XL	DGC26025			
		G	DGPG602534	DGPG602501	DGPG6025 __		DGH16025		DGS__YR	DGC16025			
		F	DGPF602534	DGPF602501	DGPF6025 __				DGS__XR				
		H	DGPH602534	DGPH602501	DGPH6025 __				DGS__YL				

KAISER TOOL COMPANY, INC.

Phone: 888-THINBIT (888-844-6248) or (260) 484-3620
www.thinbit.com • Orders: orders@thinbit.com • Quotes: quotes@thinbit.com

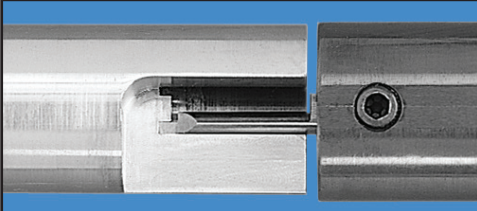
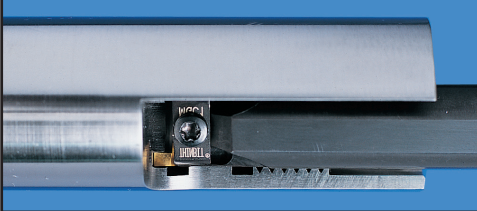
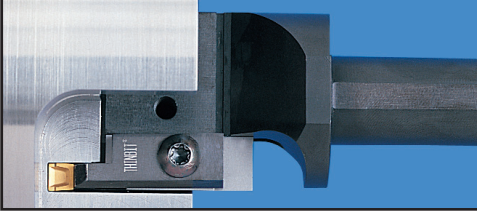
PRODUCT SELECTION GUIDE - FACE GROOVING

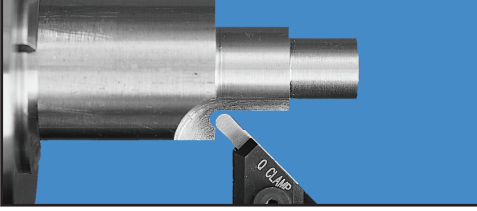
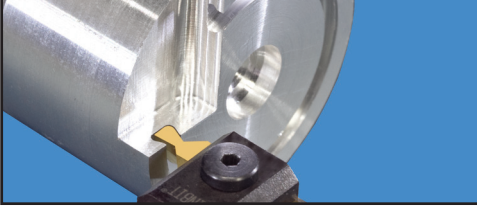
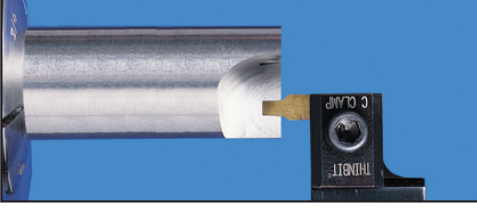
FACE GROOVING

PAGE 2-3		<ul style="list-style-type: none"> • For internal diameters of .125" and larger • Groove widths .004"-.250" • Solid carbide shanks in 1/8", 3/16", 1/4", 5/16", 3/8" and 1/2" diameter
PAGE 2-5		<ul style="list-style-type: none"> • For internal diameters of .415" and larger • Groove widths .004"-.125" • For depth of cut up to .125" • Insert can groove, bore and generate profiles
PAGE 2-7		<ul style="list-style-type: none"> • For internal diameters of 1.574" and larger • Groove widths 2, 3, 4, 5 and 6mm • For depth of cut to 1" • Inserts can also be used for parting and OD/ID grooving
PAGE 2-9		<ul style="list-style-type: none"> • Major diameters of .300", .750", 1.250" & 3" • Groove widths .004" to .150" in .001" increments • Depth of cut 2-1/2 to 3 times width • Insert can groove, turn and generate profiles
PAGE 2-9		<ul style="list-style-type: none"> • Major diameters of .300", .750", 1.250" & 3" • Groove widths .004" to .150" in .001" increments • Depth of cut 2-1/2 to 3 times width • Insert can groove, turn and generate profiles
PAGE 2-11		<ul style="list-style-type: none"> • For dovetail o-ring grooves • Groove widths .030", .050", .060", .070", .080", .090", .100", .125" & .150" • Back clearance 24° (66° undercut) • Major diameters starting from .300"
PAGE 2-13		<ul style="list-style-type: none"> • For static o-ring grooves • Groove widths .086", .103", .122", .138" & .125" • 7° included angle • Major diameters starting from .300"
PAGE 2-15		<ul style="list-style-type: none"> • Groove widths 2, 3, 4, 5 and 6mm • For depth of cut to 1" • Inserts can also be used for parting and OD/ID grooving • Major diameters starting from .787"

KAISER TOOL COMPANY, INC.

Phone: 888-THINBIT (888-844-6248) or (260) 484-3620
www.thinbit.com • Orders: orders@thinbit.com • Quotes: quotes@thinbit.com

TOOLING ORIENTATION GUIDE - FACE GROOVING

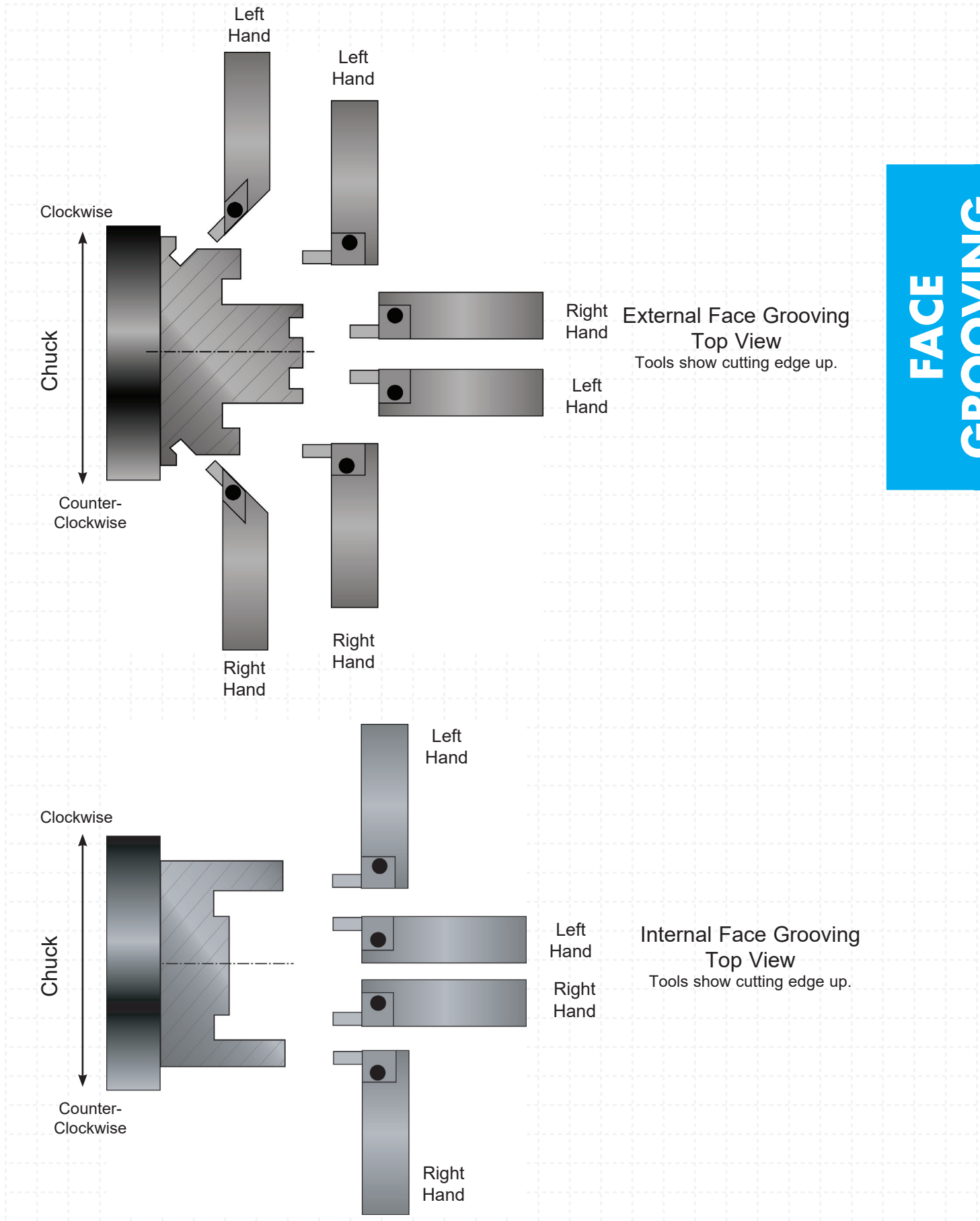

KAISER TOOL COMPANY, INC.

Phone: 888-THINBIT (888-844-6248) or (260) 484-3620
www.thinbit.com • Orders: orders@thinbit.com • Quotes: quotes@thinbit.com

MICROBIT®

PRODUCT INFORMATION

- Internal face grooving for diameters .125" and larger.
- Elliptically ground necks for greater strength.
- .004" through .250" in .001" increments available.
- 1/8", 3/16", 1/4", 5/16", 3/8" and 1/2" shanks.
- Sub-micron grain **DURA-MAX® 2000** Carbide.
- Inserts available with TiN, TiAlN, TiCN and Diamond coating.

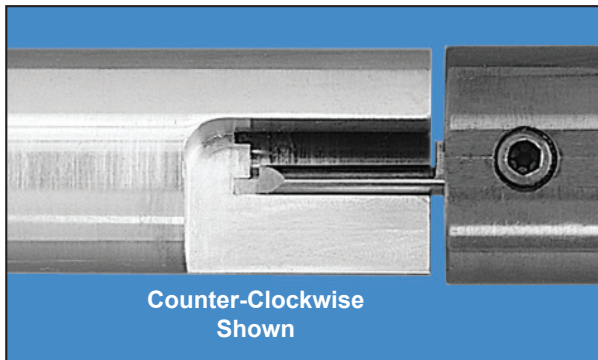

MODIFICATIONS

SEE PAGE
8-3
FOR ADDITIONAL
INFORMATION

RADI (TOP VIEW) PG 8-6	LEAD ANGLE (TOP VIEW) 	INCLUDED ANGLE (TOP VIEW) 	BACK CLEARANCE (TOP VIEW)
CUSTOM BLANK (TOP VIEW) PG 8-6	TOP RAKE (SIDE VIEW) 	CHIP BREAKER (SIDE VIEW) 	SIDE CLEARANCE (END VIEW)

TOOLHOLDER SELECTIONS

ADAPTER STYLES

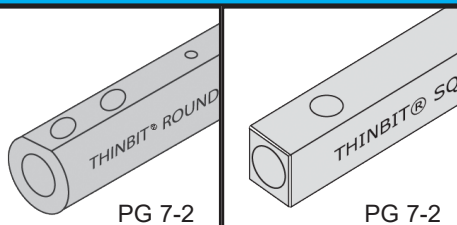

TECHNICAL SECTIONS

SPEEDS AND FEEDS	APPLICATION REFERENCE	TROUBLESHOOTING
PG 9-15	PGS 9-3 & 9-4	PG 9-7

KAISER TOOL COMPANY, INC.

Phone: 888-THINBIT (888-844-6248) or (260) 484-3620
www.thinbit.com • Orders: orders@thinbit.com • Quotes: quotes@thinbit.com

INTERNAL FACE GROOVING TOOLS

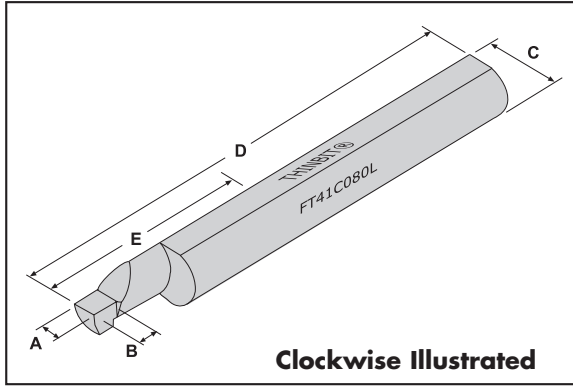

FRONT RAKE: Primary 10°
 BACK CLEARANCE: 2° ID side
 SIDE CLEARANCE: 2° ID side
 RADIUS: Sharp corner through full radius available
 TOP RAKE: 0°
 LEAD ANGLE: 0°

Clockwise Illustrated

INTERNAL
FACE GROOVING

ORDERING INSTRUCTIONS

Complete the **ORDER CODE** in the table below that represents your selection of groove width and tool dimensions.

EXAMPLE:

The **ORDER CODE** for a 1/4" major diameter, clockwise rotation tool with an .080" groove width, .125" depth of cut and .750" reach is:

FT41C 080 L

Specify the Groove Width 'A' ↑

SPECIFICATIONS				ORDER CODE			INFORMATION			
Minimum Bore & Major Diameter	Groove Width Range	Depth of Cut	Reach into Bore	DURA-MAX® 2000 Carbide See Page 9-15 for Speeds and Feeds		Add-ons Use 'Order Code' and Add		Overall Length	Toolholder Page 7-2	
'C'	'A' ± .001"	'B'	'E'	Counter-Clockwise	Clockwise	Full Radius Page 8-3	Corner Radius Page 8-3	Coating Page 9-6	'D'	Use Toolholders Beginning With
1/8"	.004"-.063"	Width DOC .004"-.020" = 3 x 'A' .021"-.063" = .062"	.375"	FT21C ___ R	FT21C ___ L				1.365" + 'B'	'AD'
3/16"	.004"-.093"	Width DOC .004"-.030" = 3 x 'A' .031"-.093" = .093"	.625"	FT31C ___ R	FT31C ___ L				1.865" + 'B'	'AD'
1/4"	.004"-.125"	Width DOC .004"-.041" = 3 x 'A' .042"-.125" = .125"	.750"	FT41C ___ R	FT41C ___ L			TiN add 'C'	2.365" + 'B'	'AD'
5/16"	.004"-.156"	Width DOC .004"-.051" = 3 x 'A' .052"-.156" = .156"	1.000"	FT51C ___ R	FT51C ___ L	add 'FR'	add 'CR' ___ (indicate size in .xxx")	TiCN add 'D'	2.330" + 'B'	'AD'
3/8"	.004"-.187"	Width DOC .004"-.061" = 3 x 'A' .062"-.187" = .187"	1.250"	FT61C ___ R	FT61C ___ L			TiAlN add 'E'	2.800" + 'B'	'AD'
1/2"	.004"-.250"	Width DOC .004"-.082" = 3 x 'A' .083"-.250" = .250"	1.750"	FT81C ___ R	FT81C ___ L			Diamond add 'F'	3.240" + 'B'	'AD'

KAISER TOOL COMPANY, INC.

Phone: 888-THINBIT (888-844-6248) or (260) 484-3620
 www.thinbit.com • Orders: orders@thinbit.com • Quotes: quotes@thinbit.com

PRODUCT INFORMATION	<ul style="list-style-type: none"> Internal face grooving and profiling for diameters of .415" and larger. Shank sizes 3/8", 1/2" and 5/8" in steel; 3/8" and 1/2" in heavy metal. 1/2" and 5/8" diameter toolholders are reversible for right and left hand orientation. Modifications can be provided on any of our tooling. Please contact us with your application requirements.
----------------------------	--



TECHNICAL SECTIONS	SPEEDS AND FEEDS	APPLICATION REFERENCE	TROUBLESHOOTING
	PG 9-12	PGS 9-3 & 9-4	PG 9-7

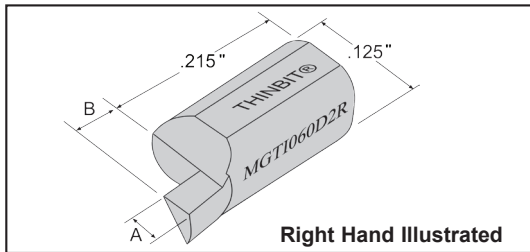

FRONT RAKE: 15°
 BACK CLEARANCE: 2° both sides
 SIDE CLEARANCE: 2° I.D. side
 RADIUS: Sharp corner through full radius available
 TOP RAKE: 0°
 LEAD ANGLE: 0°
 'A' TOLERANCE:
 .004" - .063": +.0009/-.0000
 .064" - .125": +.001/-.001

SPECIFICATIONS			ORDER CODE			
Insert Orientation	Insert Width	Depth of Cut	Insert Grades		Add-ons	
	'A'	'B'	DURA-MAX® 2000 Carbide For Steel & Interrupted Cutting	DURA-MAX® 5000 Carbide For Aluminum & Nonferrous	Full Radius Page 8-3	Corner Radius Page 8-3
Right Hand For ID grooving use left hand 'MGT' Page 1-5 For face grooving use right hand 'MGTF' Page 2-6	.004"-.063"	$\frac{\text{Width}}{\text{DOC}}$.004"-.031" = 2 x 'A' .032"-.063" = .063"	MGTI ___ _D2R	MGTI ___ _D5R	add 'FR'	add 'CR___' (indicate size in .xxx")
	.064"-.125"	$\frac{\text{Width}}{\text{DOC}}$.064"-.083" = 1.5 x 'A' .084"-.125" = .125"				
Left Hand For ID grooving use right hand 'MGT' Page 1-5 For face grooving use left hand 'MGTF' Page 2-6	.004"-.063"	$\frac{\text{Width}}{\text{DOC}}$.004"-.031" = 2 x 'A' .032"-.063" = .063"	MGTI ___ _D2L	MGTI ___ _D5L	add 'FR'	add 'CR___' (indicate size in .xxx")
	.064"-.125"	$\frac{\text{Width}}{\text{DOC}}$.064"-.083" = 1.5 x 'A' .084"-.125" = .125"				

KAISER TOOL COMPANY, INC.

Phone: 888-THINBIT (888-844-6248) or (260) 484-3620
 www.thinbit.com • Orders: orders@thinbit.com • Quotes: quotes@thinbit.com

I.D. FACE GROOVING TOOLS

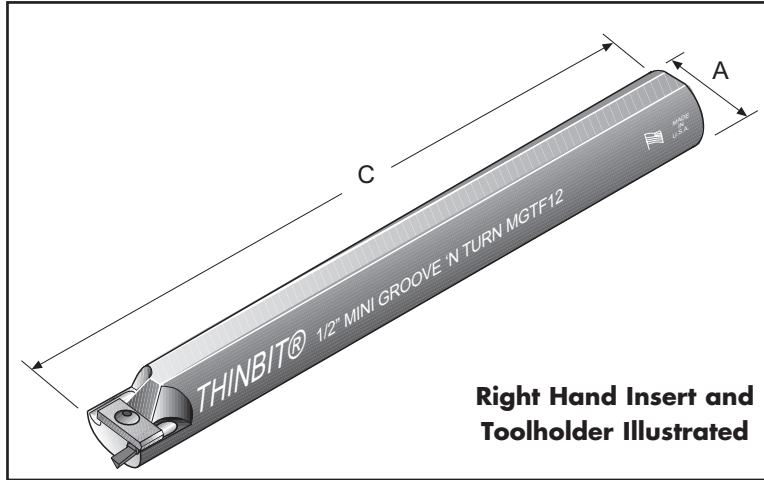

Note:

- 1/2" and 5/8" toolholders are reversible for right hand or left hand orientation.

- For face grooving:

Insert Width	Depth of Cut
.004"-.031"	2 x width
.032"-.063"	.063"
.064"-.083"	1.5 x width
.084"-.125"	.125"

I.D. FACE GROOVING

ORDERING INSTRUCTIONS

Select the **ORDER CODE** in the table below that represents your selection of tool specifications.

EXAMPLE:

The **ORDER CODE** for a .530" minimum bore and a 1/2" steel shank is:
MGTF12

SPECIFICATIONS		ORDER CODE				INFORMATION		
Minimum Bore & Major Diameter	Orientation & Toolholder Material	Toolholder Package Includes Shank, Clamp and Hardware	Replacement Parts			Shank Diameter 'A'	Shank Length 'C'	Inserts Page 2-5 Use Inserts Beginning With
			Clamp Only	Screw Only	Wrench Only			
.415"	Right Hand Steel	MGTF38R	MGC1	F31	W31	3/8"	5.500"	'MGTI' Use right hand inserts
	Right Hand Heavy Metal	MGTF38RHM					5.485"	
	Left Hand Steel	MGTF38L					5.500"	'MGTI' Use left hand inserts
	Left Hand Heavy Metal	MGTF38LHM					5.485"	
.530"	Steel	MGTF12				1/2"	5.500"	'MGTI' Use with left hand inserts for clockwise or with right hand inserts for counter-clockwise
	Heavy Metal	MGTF12HM					5.485"	
.650"	Steel	MGTF58				5/8"	5.500"	

KAISER TOOL COMPANY, INC.

Phone: 888-THINBIT (888-844-6248) or (260) 484-3620
www.thinbit.com • Orders: orders@thinbit.com • Quotes: quotes@thinbit.com

PRODUCT INFORMATION

- Internal face grooving for diameters 1.574" and larger with depth of cut to 1".
- Shank sizes 3/4", 1", 20mm & 25mm.
- Modular tooling system will also accept OD & external face grooving heads. See compatibility guide on Page 9-8.
- If square shank is required, see Page 7-16, package styles 'S', 'T', 'U' and 'V'.
- Modifications can be provided on any of our tooling. Please contact us with your application requirements.

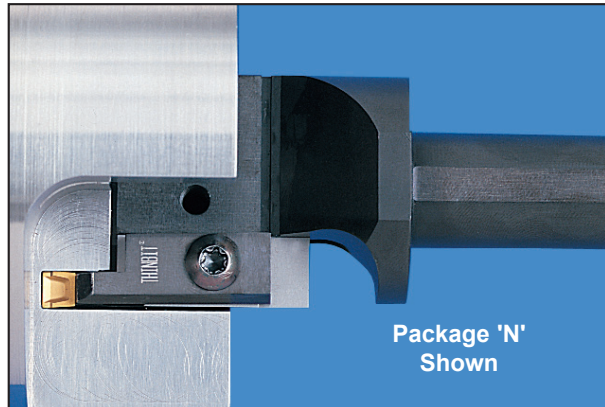

INSERT SELECTIONS SEE PAGE 6-1	INSERT STYLES	
	CORNER RADIUS (TOP VIEW)	SHARP CORNER (TOP VIEW)

TECHNICAL SECTIONS	SPEEDS AND FEEDS	APPLICATION REFERENCE	TROUBLESHOOTING
		PG 9-12	PGS 9-3 & 9-4

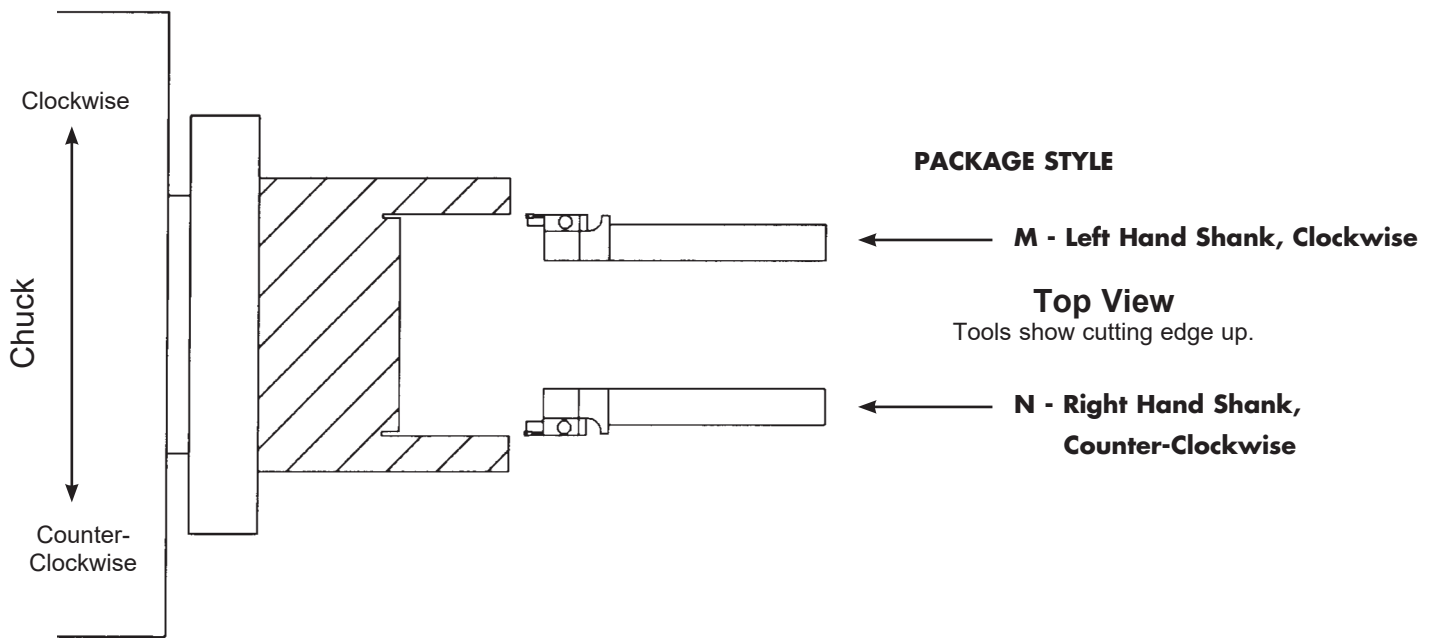

Note: If square shank is required, see Page 7-16, package styles 'S','T','U' and 'V'.

KAISER TOOL COMPANY, INC.

Phone: 888-THINBIT (888-844-6248) or (260) 484-3620
 www.thinbit.com • Orders: orders@thinbit.com • Quotes: quotes@thinbit.com

I.D. FACE GROOVING TOOLS

ORDERING INSTRUCTIONS

Complete the ORDER CODE in the table below that represents your selection of major diameter.

EXAMPLE:

The **ORDER CODE** for a 3mm insert width, toolholder package style 'N' with a .500" depth of cut, 1" shank and 1.75" major diameter is:

DGPN301301 4 5

Specify Major Diameter '**CODE**' here ↑

I.D. FACE GROOVING

SPECIFICATIONS			ORDER CODE									
Insert Width	Depth of Cut	Package Style	Toolholder Package <small>Includes Shank, Head, Clamp and Hardware</small>				Inserts Use Inserts Beginning With	Replacement Parts				
			3/4" Shank <small>7" Long</small>	1" Shank <small>7" Long</small>	20mm Shank <small>178mm (7") Long</small>	25mm Shank <small>178mm (7") Long</small>		Head	Head Hardware	Shank <small>34 = 3/4" 01 = 1" 20 = 20mm 25 = 25mm</small>	Clamp	Clamp Hardware
2mm (.078")	13mm (1/2")	M	DGPM201334 __	DGPM201301 __	DGPM201320 __	DGPM201325 __	'DG12' (Page 6-1)	DGH52013 __	Screw: 2 each S7552 Wrench: W4025	DGS__ZL	DGC52013	Screw: S6552 Wrench: W4025
		N	DGPN201334 __	DGPN201301 __	DGPN201320 __	DGPN201325 __		DGH62013 __		DGS__ZR	DGC62013	
3mm (.118")	13mm (1/2")	M	DGPM301334 __	DGPM301301 __	DGPM301320 __	DGPM301325 __	'DG13' (Page 6-1)	DGH53013 __		DGS__ZL	DGC53013	
		N	DGPN301334 __	DGPN301301 __	DGPN301320 __	DGPN301325 __		DGH63013 __		DGS__ZR	DGC63013	
4mm (.157")	13mm (1/2")	M	DGPM401334 __	DGPM401301 __	DGPM401320 __	DGPM401325 __	'DG14' (Page 6-1)	DGH54013 __		DGS__ZL	DGC54013	
		N	DGPN401334 __	DGPN401301 __	DGPN401320 __	DGPN401325 __		DGH64013 __		DGS__ZR	DGC64013	
	20mm (3/4")	M	DGPM402034 __	DGPM402001 __	DGPM402020 __	DGPM402025 __		DGH54020 __		DGS__ZL	DGC54020	
		N	DGPN402034 __	DGPN402001 __	DGPN402020 __	DGPN402025 __		DGH64020 __		DGS__ZR	DGC64020	
5mm (.197")	13mm (1/2")	M	DGPM501334 __	DGPM501301 __	DGPM501320 __	DGPM501325 __	'DG15' (Page 6-1)	DGH55013 __		DGS__ZL	DGC55013	
		N	DGPN501334 __	DGPN501301 __	DGPN501320 __	DGPN501325 __		DGH65013 __		DGS__ZR	DGC65013	
	25mm (1")	M	DGPM502534 __	DGPM502501 __	DGPM502520 __	DGPM502525 __		DGH55025 __	DGS__ZL	DGC55025		
		N	DGPN502534 __	DGPN502501 __	DGPN502520 __	DGPN502525 __		DGH65025 __	DGS__ZR	DGC65025		
6mm (.236")	13mm (1/2")	M	DGPM601334 __	DGPM601301 __	DGPM601320 __	DGPM601325 __	'DG16' (Page 6-1)	DGH56013 __	DGS__ZL	DGC56013		
		N	DGPN601334 __	DGPN601301 __	DGPN601320 __	DGPN601325 __		DGH66013 __	DGS__ZR	DGC66013		
	25mm (1")	M	DGPM602534 __	DGPM602501 __	DGPM602520 __	DGPM602525 __		DGH56025 __	DGS__ZL	DGC56025		
		N	DGPN602534 __	DGPN602501 __	DGPN602520 __	DGPN602525 __		DGH66025 __	DGS__ZR	DGC66025		



Major Diameter Range	Code
1.574"-1.968" (40-50mm)	45
1.968"-2.362" (50-60mm)	56
2.362"-2.952" (60-75mm)	67
2.952"-3.937" (75-100mm)	71
3.937"-5.905" (100-150mm)	11
5.905"-11.811" (150-300mm)	13
11.811"- ∞ (300mm-∞)	30

Note:

As long as first plunge is made within major diameter range and each following plunge overlaps, groove width can be increased toward or away from center of part.

KAISER TOOL COMPANY, INC.

Phone: 888-THINBIT (888-844-6248) or (260) 484-3620
www.thinbit.com • Orders: orders@thinbit.com • Quotes: quotes@thinbit.com

GROOVE 'N TURN® INSERTS

U.S. PATENT NOS. 6,688,816 and 6,824,333

PRODUCT INFORMATION

- Face grooving for major diameters .300", .750", 1.250", 3" and greater.
- Face grooving with a central hub, recessed or flat face.
- .004" - .150" in .001" increments available.
- Sub-micron grain **DURA-MAX® 2000** and **5000** Carbides.
- Inserts available with TiN, TiAlN, TiCN and Diamond coating.



MODIFICATIONS

SEE PAGES 8-2 & 8-3 FOR ADDITIONAL INFORMATION

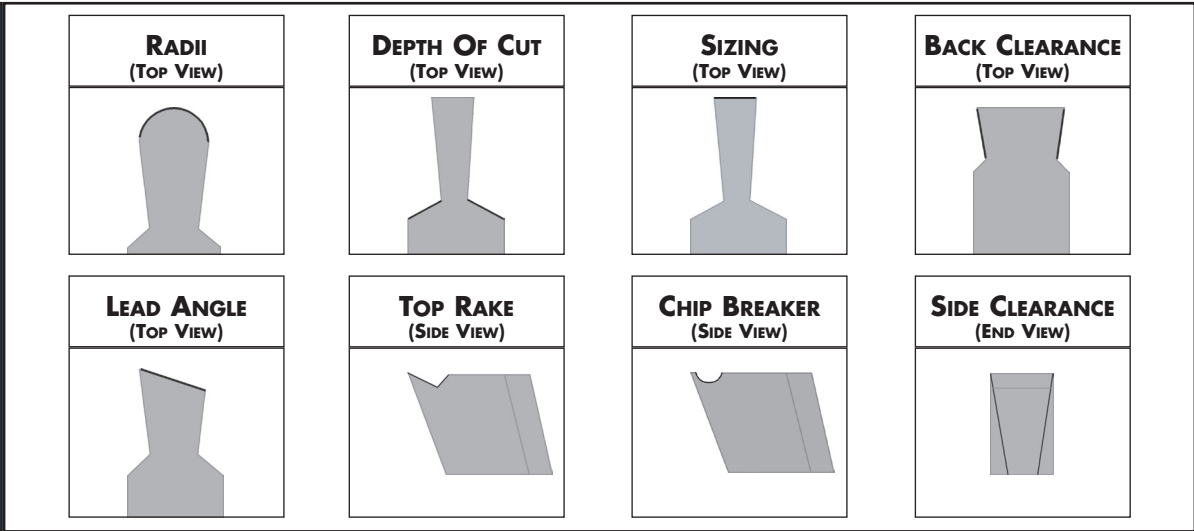

TOOLHOLDER SELECTIONS

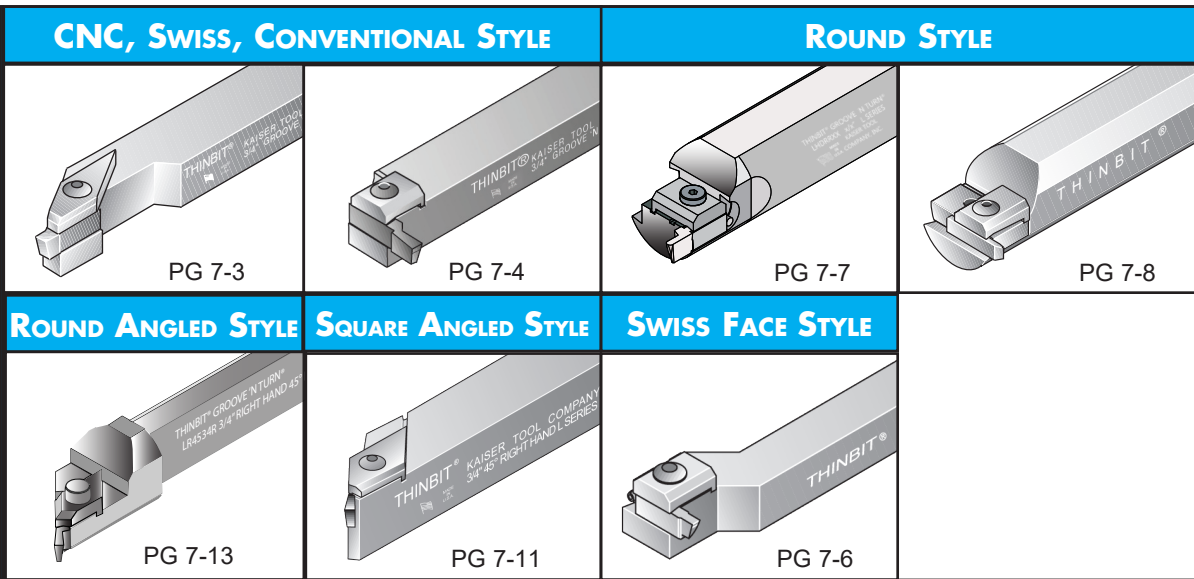

TECHNICAL SECTIONS

SPEEDS AND FEEDS	APPLICATION REFERENCE	TROUBLESHOOTING
PG 9-12	PGS 9-3 & 9-4	PG 9-7

KAISER TOOL COMPANY, INC.

Phone: 888-THINBIT (888-844-6248) or (260) 484-3620
 www.thinbit.com • Orders: orders@thinbit.com • Quotes: quotes@thinbit.com

FACE GROOVING INSERTS

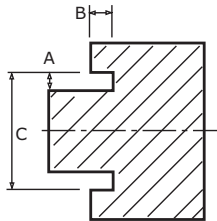
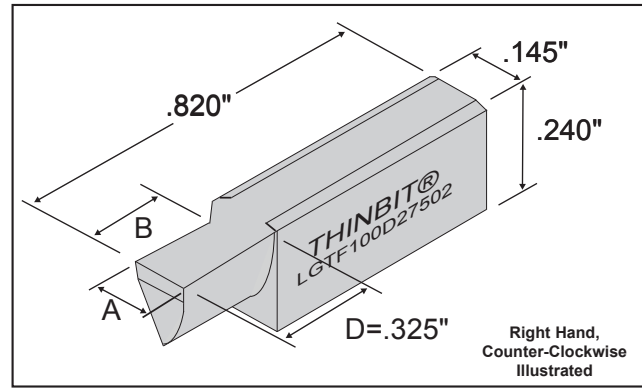
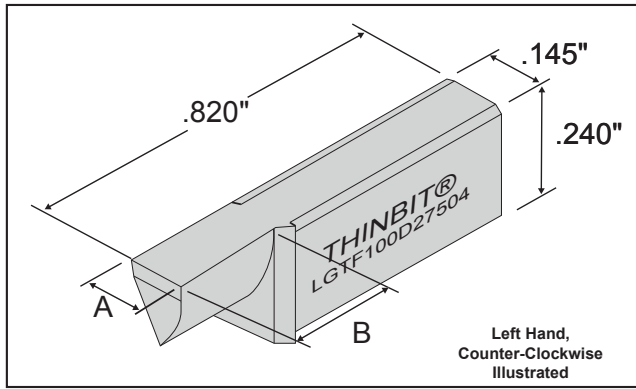

Cut with a LH CCW Insert

FRONT RAKE: Primary 10° honed, Secondary 15°
BACK CLEARANCE: 2-1/2° both sides
SIDE CLEARANCE: .004" - .019" - 0° ID side
 .020" - .150" - 5° ID side
RADIUS: Sharp corner through full radius available
TOP RAKE: 0°
LEAD ANGLE: 0°

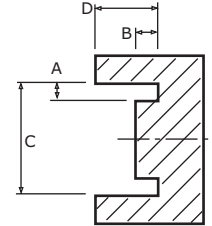

Cut with a RH CCW Insert

NOTE: Capable of grooving along a shoulder

**INSERTS
FACE GROOVING**

ORDERING INSTRUCTIONS

EXAMPLE:

Sample **ORDER CODE** for a left hand/counter-clockwise, .100" wide insert in **DURA-MAX® 2000**, with a .750" major diameter and no corner radius is:

LGTF 1 0 0 D27504

Specify the Insert Width 'A' ↑

SPECIFICATIONS				ORDER CODE				INFO.	
Insert Orientation	Insert Width 'A' ± .001"	Depth of Cut 'B'	Major Diameter Can be used on any diameter equal to or greater than listed	Insert Grades <small>See Page 9-5 for expanded material descriptions and Page 9-12 for Speeds and Feeds information</small>		Add-ons <small>Use 'Order Code' and Add</small>			Toolholder Catalog Section 7 Use Toolholders Beginning With 'L'
				DURA-MAX® 2000 Carbide For Steel & Interrupted Cutting	DURA-MAX® 5000 Carbide For Aluminum & Nonferrous	Full Radius Page 8-3	Corner Radius Page 8-3	Coating Page 9-6	
Left Hand/ Counter-Clockwise	.004" - .150"	<small>Width D.O.C.</small> .004"-.033" = 3 x 'A' .034"-.039" = .100" .040"-.100" = 2.5 x 'A' .101"-.150" = .250"	.300"	LGTF ___ D23004	LGTF ___ D53004	add 'FR'	add 'CR___' (indicate size in .xxx")	TiN add 'C' TiCN add 'D' TiAlN add 'E' Diamond add 'F'	For shoulder cutting use left hand straight holder or right hand 90° holder
			.750"	LGTF ___ D27504	LGTF ___ D57504				
			1.250"	LGTF ___ D212504	LGTF ___ D512504				
			* 3.000"	LGT ___ D2L	LGT ___ D5L				
Right Hand/ Counter-Clockwise	.004" - .150"	<small>Width D.O.C.</small> .004"-.033" = 3 x 'A' .034"-.039" = .100" .040"-.100" = 2.5 x 'A' .101"-.150" = .250"	.300"	LGTF ___ D23002	LGTF ___ D53002	add 'FR'	(indicate size in .xxx")	TiN add 'C' TiCN add 'D' TiAlN add 'E' Diamond add 'F'	Use right hand or left hand straight holder or right hand 90° holder
			.750"	LGTF ___ D27502	LGTF ___ D57502				
			1.250"	LGTF ___ D212502	LGTF ___ D512502				
			* 3.000"	LGT ___ D2R	LGT ___ D5R				

* 3.000" Major Diameter Excludes .004" - .019" Insert Width Due to Side Clearance

KAISER TOOL COMPANY, INC.

Phone: 888-THINBIT (888-844-6248) or (260) 484-3620
 www.thinbit.com • Orders: orders@thinbit.com • Quotes: quotes@thinbit.com

GROOVE 'N TURN[®] INSERTS

U.S. PATENT NOS. 6,688,816 and 6,824,333

PRODUCT INFORMATION

- For Dovetail O-Ring face grooving and OD/ID grooving.
- Groove Widths .030", .050", .060", .070", .080", .090", .100", .125" & .150".
- Major diameters from .300".
- Sub-micron grain **DURA-MAX[®] 2000** and **5000** Carbides.
- Inserts available with TiN, TiCN, TiAlN or Diamond film coating.



MODIFICATIONS

SEE PAGES
8-2 & 8-3
FOR ADDITIONAL
INFORMATION

RADI (TOP VIEW)	DEPTH OF CUT (TOP VIEW)	SIZING (TOP VIEW)	BACK CLEARANCE (TOP VIEW)
LEAD ANGLE (TOP VIEW)	TOP RAKE (SIDE VIEW)	CHIP BREAKER (SIDE VIEW)	SIDE CLEARANCE (END VIEW)

TOOLHOLDER SELECTIONS

CNC, SWISS, CONVENTIONAL STYLE	ROUND STYLE		
 PG 7-3	 PG 7-4	 PG 7-7	 PG 7-8
ROUND ANGLED STYLE	SQUARE ANGLED STYLE	SWISS FACE STYLE	
 PG 7-13	 PG 7-11	 PG 7-6	

TECHNICAL SECTIONS

SPEEDS AND FEEDS	APPLICATION REFERENCE	TROUBLESHOOTING
PG 9-12	PGS 9-3 & 9-4	PG 9-7

KAISER TOOL COMPANY, INC.

Phone: 888-THINBIT (888-844-6248) or (260) 484-3620
www.thinbit.com • Orders: orders@thinbit.com • Quotes: quotes@thinbit.com

DOVETAIL O-RING FACE GROOVING INSERTS

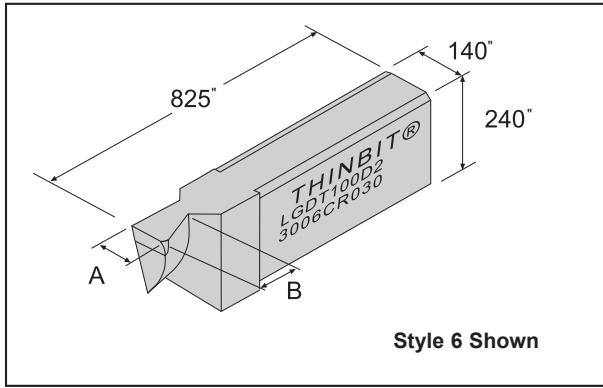

Style 6 Shown

FRONT RAKE: Primary 10° honed, Secondary 15°
 BACK CLEARANCE: 24° one side
 SIDE CLEARANCE: Depends on major diameter
 RADIUS: On 24° side only - Non-Angled sharp
 TOP RAKE: 0°
 LEAD ANGLE: 0°

Notes:

- For best performance, form undercut by profiling.
- If using on either an ID Bore or OD Shaft contact us for assistance.
- Half dovetail form requires a radius on both corners.

DOVE TAIL FACE GROOVING

ORDERING INSTRUCTIONS

Select the **ORDER CODE** in the table below that represents your selection of groove width and insert grade.

EXAMPLE:

The **ORDER CODE** for a left hand/counter-clockwise, .100" wide OD side insert in **DURA-MAX® 2000**, with a .300" major diameter and a .030" corner radius is:

LGDT100D23006CR030

SPECIFICATIONS				ORDER CODE				INFO.	
Insert Orientation & Radius	Insert Width 'A' ± .001"	Depth of Cut 'B'	Radius	Insert Grades See Page 9-5 for expanded material descriptions and Page 9-12 for Speeds and Feeds information				Add-ons Use 'Order Code' and Add Coating Page 9-6	Toolholder Catalog Section 7 Use Toolholders Beginning With
				DURA-MAX® 2000 Carbide For Steel & Interrupted Cutting		DURA-MAX® 5000 Carbide For Aluminum & Nonferrous			
				Style 5 (ID Tool)	Style 6 (OD Tool)	Style 5 (ID Tool)	Style 6 (OD Tool)		
Left Hand/ Counter- Clockwise	.030"	.030"	.015"	LGDT030D2__5CR015	LGDT030D2__6CR015	LGDT030D5__5CR015	LGDT030D5__6CR015	TiN add 'C' TiCN add 'D' TiAlN add 'E' Diamond add 'F'	'L'
	.050"	.070"	.015"	LGDT050D2__5CR015	LGDT050D2__6CR015	LGDT050D5__5CR015	LGDT050D5__6CR015		
	.060"	.070"	.015"	LGDT060D2__5CR015	LGDT060D2__6CR015	LGDT060D5__5CR015	LGDT060D5__6CR015		
	.070"	.100"	.015"	LGDT070D2__5CR015	LGDT070D2__6CR015	LGDT070D5__5CR015	LGDT070D5__6CR015		
	.080"	.100"	.015"	LGDT080D2__5CR015	LGDT080D2__6CR015	LGDT080D5__5CR015	LGDT080D5__6CR015		
	.090"	.115"	.015"	LGDT090D2__5CR015	LGDT090D2__6CR015	LGDT090D5__5CR015	LGDT090D5__6CR015		
	.100"	.125"	.015"	LGDT100D2__5CR015	LGDT100D2__6CR015	LGDT100D5__5CR015	LGDT100D5__6CR015		
	.100"	.125"	.030"	LGDT100D2__5CR030	LGDT100D2__6CR030	LGDT100D5__5CR030	LGDT100D5__6CR030		
	.125"	.190"	.030"	LGDT125D2__5CR030	LGDT125D2__6CR030	LGDT125D5__5CR030	LGDT125D5__6CR030		
.150"	.200"	.030"	LGDT150D2__5CR030	LGDT150D2__6CR030	LGDT150D5__5CR030	LGDT150D5__6CR030			

Major Diameter Code

Major Diameter	Code
.300"	300
.500"	500
1.000"	1000
1.500"	1500
2.000"	2000
3.000"	3000

Dovetail Insert Styles

Note: both styles 5 & 6 are necessary to create a complete dovetail groove.

Style 5 (ID Tool) and Style 6 (OD Tool) are shown cutting into a workpiece to form a dovetail groove.

KAISER TOOL COMPANY, INC.

Phone: 888-THINBIT (888-844-6248) or (260) 484-3620
 www.thinbit.com • Orders: orders@thinbit.com • Quotes: quotes@thinbit.com

GROOVE 'N TURN® INSERTS

U.S. PATENT NOS. 6,688,816 and 6,824,333

PRODUCT INFORMATION

- For Static O-Ring Face Grooving.
- Groove widths .086", .103", .122", .125" & .138".
- 7° included angle.
- Major diameters starting from .300".
- Sub-micron grain **DURA-MAX® 2000** and **5000** Carbides.
- Inserts available with TiN, TiCN, TiAlN or Diamond film coating.

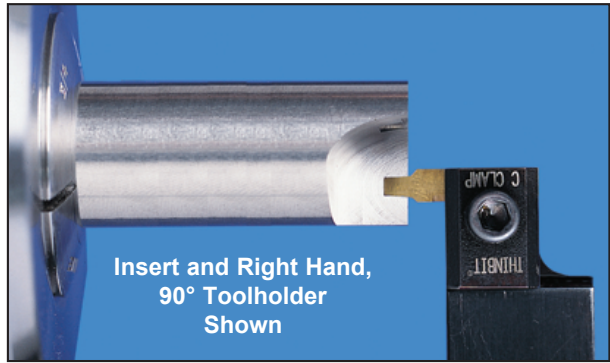

MODIFICATIONS
SEE PAGES 8-2 & 8-3 FOR ADDITIONAL INFORMATION

RADI (TOP VIEW)	DEPTH OF CUT (TOP VIEW)	SIZING (TOP VIEW)	BACK CLEARANCE (TOP VIEW)
LEAD ANGLE (TOP VIEW)	TOP RAKE (SIDE VIEW)	CHIP BREAKER (SIDE VIEW)	SIDE CLEARANCE (END VIEW)

TOOLHOLDER SELECTIONS

CNC, SWISS, CONVENTIONAL STYLE	ROUND STYLE		
 PG 7-3	 PG 7-4	 PG 7-7	 PG 7-8
ROUND ANGLED STYLE	SQUARE ANGLED STYLE	SWISS FACE STYLE	
 PG 7-13	 PG 7-11	 PG 7-6	

TECHNICAL SECTIONS	SPEEDS AND FEEDS	APPLICATION REFERENCE	TROUBLESHOOTING
	PG 9-12	PGS 9-3 & 9-4	PG 9-7

KAISER TOOL COMPANY, INC.

Phone: 888-THINBIT (888-844-6248) or (260) 484-3620
www.thinbit.com • Orders: orders@thinbit.com • Quotes: quotes@thinbit.com

STATIC O-RING FACE GROOVING INSERTS

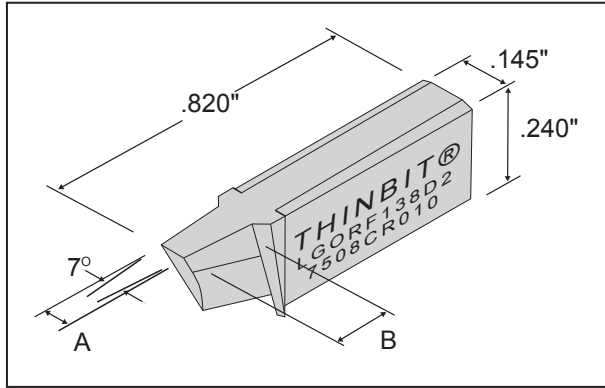

FRONT RAKE: Primary 10° honed, Secondary 15°
 BACK CLEARANCE: 7° included angle
 SIDE CLEARANCE: 5° both sides
 RADIUS: .010" or .020"
 TOP RAKE: 0°
 LEAD ANGLE: 0°
 DEPTH OF CUT: .170" or .250"

**STATIC O-RING
FACE GROOVING**

ORDERING INSTRUCTIONS

Select the **ORDER CODE** in the table below that represents your selection of groove width and insert grade.

EXAMPLE:

The **ORDER CODE** for a counter-clockwise, .138" wide insert in **DURA-MAX® 2000**, with a .750" major diameter and a .010" corner radius is:
LGORF138D27508CR010

SPECIFICATIONS				ORDER CODE		INFO.	
Insert Orientation & Radius	Insert Width 'A' ± .001"	Depth of Cut 'B'	Major Diameter Can be used on any diameter equal to or greater than listed	Insert Grades See Page 9-5 for expanded material descriptions and Page 9-12 for Speeds and Feeds information		Add-ons Use 'Order Code' and Add Coating Page 9-6	Toolholder Catalog Section 7 Use Toolholders Beginning With
				DURA-MAX® 2000 Carbide For Steel & Interrupted Cutting	DURA-MAX® 5000 Carbide For Aluminum & Non-ferrous		
Counter-Clockwise; .010" Corner Radius	.086"	.250"	.300"	LGORF086D23008CR010	LGORF086D53008CR010	TiN add 'C' TiCN add 'D' TiAlN add 'E' Diamond add 'F'	'L' Use left hand straight holder or right hand 90° holder
			.750"	LGORF086D27508CR010	LGORF086D57508CR010		
	.103"	.250"	.300"	LGORF103D23008CR010	LGORF103D53008CR010		
			.750"	LGORF103D27508CR010	LGORF103D57508CR010		
	.122"	.250"	.300"	LGORF122D23008CR010	LGORF122D53008CR010		
			.750"	LGORF122D27508CR010	LGORF122D57508CR010		
	.138"	.170"	.300"	LGORF138D23008CR010	LGORF138D53008CR010		
			.750"	LGORF138D27508CR010	LGORF138D57508CR010		
Counter-Clockwise; .020" Corner Radius	.125"	.250"	.300"	LGORF125D23008CR020	LGORF125D53008CR020		
			.750"	LGORF125D27508CR020	LGORF125D57508CR020		

KAISER TOOL COMPANY, INC.

Phone: 888-THINBIT (888-844-6248) or (260) 484-3620
 www.thinbit.com • Orders: orders@thinbit.com • Quotes: quotes@thinbit.com

DEEPGROOVE®

U.S. PATENT NO. 5,638,728

PRODUCT INFORMATION

- External face grooving with depth of cut to 1".
- Shank sizes 3/4", 1", 16mm, 20mm and 25mm in straight and 90° orientations.
- Modular tooling system will also accept OD & internal face grooving heads. See compatibility guide on Page 9-8.
- If round shanks are required, see Page 7-15, package styles 'O' and 'P'.
- Modifications can be provided on any of our tooling. Please contact us with your application requirements.
- Major diameter starting from .787".

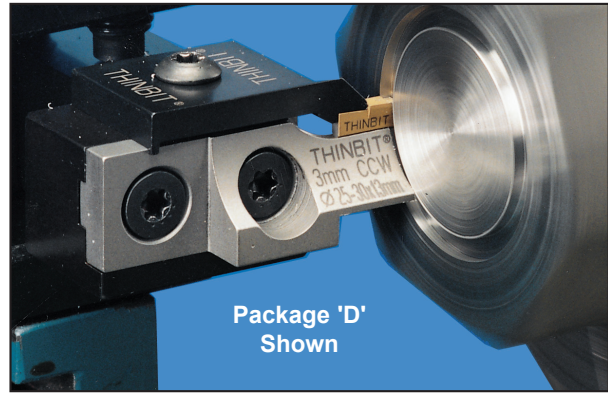

INSERT SELECTIONS SEE PAGE 6-1

INSERT STYLES

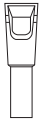
CORNER RADIUS (Top View)	SHARP CORNER (Top View)
	

TECHNICAL SECTIONS

SPEEDS AND FEEDS	APPLICATION REFERENCE	TROUBLESHOOTING
PG 9-12	PGS 9-3 & 9-4	PG 9-7

ORDERING INSTRUCTIONS

3/4", 1" and Metric Shanks

Select the **ORDER CODE** in the table at right that represents your selection of major diameter.

EXAMPLE:

The **ORDER CODE** for a 3mm insert width, toolholder package style 'C' with a .500" depth of cut, 1" shank and 1" major diameter is:

DGPC301301 23

Specify the 'SHANK SIZE' and MAJOR DIAMETER 'CODE'

PACKAGE STYLE

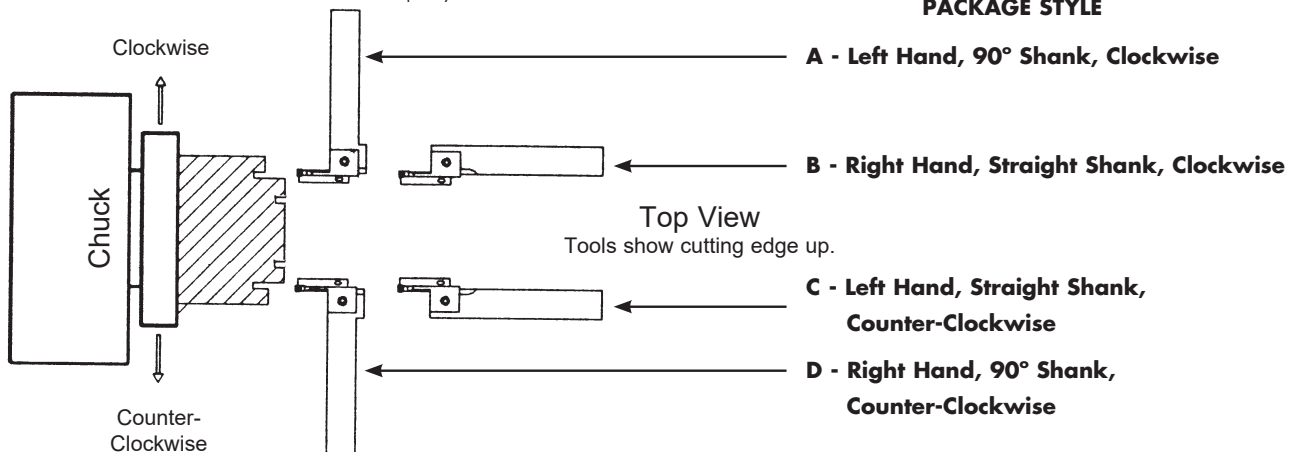

Note: If round shanks are required, see Page 7-15, package styles 'O' and 'P'.

KAISER TOOL COMPANY, INC.

Phone: 888-THINBIT (888-844-6248) or (260) 484-3620
www.thinbit.com • Orders: orders@thinbit.com • Quotes: quotes@thinbit.com

FACE GROOVING TOOLS

SPECIFICATIONS			ORDER CODE								
Insert Width	Depth of Cut	Package Style	Toolholder Package			Inserts	Replacement Parts				
			Includes Shank, Head, Clamp and Hardware				Section 6 Use Inserts Beginning With	Head	Head Hardware	Shank 34 = 3/4" 01 = 1" 16 = 16mm 20 = 20mm 25 = 25mm	Clamp
See Page 2-15	3/4" Shank 3/4"x3/4"x5"	1" Shank 1"x1"x5"	Metric Shanks 16 = 16x16x125mm 20 = 20x1"x125mm 25 = 25x1"x125mm								
2mm (.078")	13mm (1/2")	A	DGPA201334_	DGPA201301_	DGPA2013_	'DGI2' (Page 6-1)	DGH32013_		DGS_YL	DGC12013	
		B	DGPB201334_	DGPB201301_	DGPB2013_				DGS_XR		
		C	DGPC201334_	DGPC201301_	DGPC2013_				DGS_XL		DGC22013
		D	DGPD201334_	DGPD201301_	DGPD2013_				DGS_YR		
3mm (.118")	13mm (1/2")	A	DGPA301334_	DGPA301301_	DGPA3013_	Use 'DGMI3' for major diameter codes '02' & '25' 'DGI3' for all others (Page 6-1)	DGH33013_		DGS_YL	DGC13013	
		B	DGPB301334_	DGPB301301_	DGPB3013_				DGS_XR		
		C	DGPC301334_	DGPC301301_	DGPC3013_				DGS_XL		DGC23013
		D	DGPD301334_	DGPD301301_	DGPD3013_				DGS_YR		
4mm (.157")	13mm (1/2")	A	DGPA401334_	DGPA401301_	DGPA4013_	Use 'DGMI4' for major diameter codes '02' & '25' 'DGI4' for all others (Page 6-1)	DGH34013_		DGS_YL	DGC14013	
		B	DGPB401334_	DGPB401301_	DGPB4013_				DGS_XR		
		C	DGPC401334_	DGPC401301_	DGPC4013_				DGS_XL		DGC24013
		D	DGPD401334_	DGPD401301_	DGPD4013_				DGS_YR		
	20mm (3/4")	A	DGPA402034_	DGPA402001_	DGPA4020_		DGH34020_		DGS_YL	DGC14020	
		B	DGPB402034_	DGPB402001_	DGPB4020_				DGS_XR	DGC24020	
		C	DGPC402034_	DGPC402001_	DGPC4020_				DGS_XL		
		D	DGPD402034_	DGPD402001_	DGPD4020_				DGS_YR		
5mm (.197")	13mm (1/2")	A	DGPA501334_	DGPA501301_	DGPA5013_	'DGI5' (Page 6-1)	DGH35013_	Screw: 2 each S7552 Wrench: W4025	DGS_YL	DGC15013	
		B	DGPB501334_	DGPB501301_	DGPB5013_				DGS_XR		
		C	DGPC501334_	DGPC501301_	DGPC5013_				DGS_XL		DGC25013
		D	DGPD501334_	DGPD501301_	DGPD5013_				DGS_YR		
	25mm (1")	A	DGPA502534_	DGPA502501_	DGPA5025_		DGH35025_		DGS_YL	DGC15025	
		B	DGPB502534_	DGPB502501_	DGPB5025_				DGS_XR	DGC25025	
		C	DGPC502534_	DGPC502501_	DGPC5025_				DGS_XL		
		D	DGPD502534_	DGPD502501_	DGPD5025_				DGS_YR		
6mm (.236")	13mm (1/2")	A	DGPA601334_	DGPA601301_	DGPA6013_	'DGI6' (Page 6-1)	DGH36013_	Screw: 2 each S7552 Wrench: W4025	DGS_YL	DGC16013	
		B	DGPB601334_	DGPB601301_	DGPB6013_				DGS_XR		
		C	DGPC601334_	DGPC601301_	DGPC6013_				DGS_XL		DGC26013
		D	DGPD601334_	DGPD601301_	DGPD6013_				DGS_YR		
	25mm (1")	A	DGPA602534_	DGPA602501_	DGPA6025_		DGH36025_		DGS_YL	DGC16025	
		B	DGPB602534_	DGPB602501_	DGPB6025_				DGS_XR	DGC26025	
		C	DGPC602534_	DGPC602501_	DGPC6025_				DGS_XL		
		D	DGPD602534_	DGPD602501_	DGPD6025_				DGS_YR		

**DEEPCROOVE
FACE GROOVING**

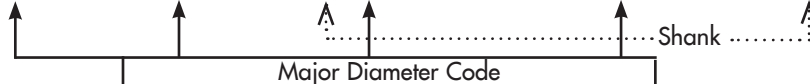

Major Diameter Range	Insert Width	Code	Insert Style	Major Diameter Range	Insert Width	Code	Insert Style	
.787"-.885" (20-22.5mm)	2mm	02	DGI	1.377"-1.574" (35-40mm)	2mm	50	DGI	
	3 & 4mm	02	DGMI		3, 4, 5 & 6mm	34	DGI	
.885"-.984" (22.5-25mm)	2mm	25	DGI		1.574"-1.968" (40-50mm)		45	DGI
	3 & 4mm	25	DGMI		1.968"-2.362" (50-60mm)		56	DGI
.984"-1.082" (25-27.5mm)	2mm	57	DGI		2.362"-2.952" (60-75mm)	All	67	DGI
	3, 4, 5 & 6mm	23	DGI		2.952"-3.937" (75-100mm)		71	DGI
	2mm	70	DGI		3.937"-5.905" (100-150mm)		11	DGI
3, 4, 5 & 6mm	23	DGI	5.905"-11.811" (150-300mm)		13		DGI	
2mm	05	DGI	11.811"-∞ (300mm-∞)		30		DGI	
1.082"-1.181" (27.5-30mm)	3, 4, 5 & 6mm	23	DGI					
1.181"-1.377" (30-35mm)	2mm	05	DGI					
	3, 4, 5 & 6mm	34	DGI					



Note:
As long as first plunge is made within major diameter range and each following plunge overlaps, groove width can be increased toward or away from center of part.

KAISER TOOL COMPANY, INC.

Phone: 888-THINBIT (888-844-6248) or (260) 484-3620
www.thinbit.com • Orders: orders@thinbit.com • Quotes: quotes@thinbit.com

PRODUCT SELECTION GUIDE - BORING, PROFILING & TURNING

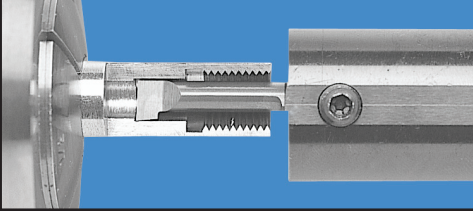
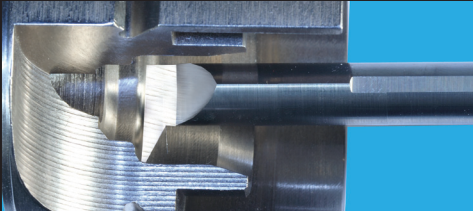
BORING

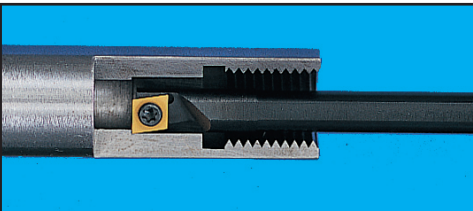
<p>PAGE 3-3</p>		<ul style="list-style-type: none"> • Finish boring • For internal diameters of .073" and larger • Solid carbide shanks in 1/8", 3/16", 1/4", 5/16", 3/8" and 1/2" diameter
<p>PAGE 3-5</p>		<ul style="list-style-type: none"> • Profiling & Reverse Profiling • For internal diameters of .125" and larger • Solid carbide shanks in 1/8", 3/16", 1/4", 5/16", 3/8" and 1/2" diameter
<p>PAGE 3-7 to 3-10</p>		<ul style="list-style-type: none"> • Rough boring using Trigon inserts • PAGE 3-8: .210" Min. Bore; MBE (WCGT) style • PAGE 3-9: .270" Min. Bore; MBF (WCGT) style • PAGE 3-10: .410" Min. Bore; MBG (WCGT) style
<p>PAGE 3-11 to 3-18</p>		<ul style="list-style-type: none"> • Finish boring • PAGE 3-12: .165" Min. Bore; MBZ style • PAGE 3-13: .180" Min. Bore; MBA (CD) style • PAGE 3-15: .270" Min. Bore; MBB (TD) style • PAGE 3-17: .430" Min. Bore; MBC (TP) style

THINBIT®

OVER 100,000 TOOLS IN STOCK FOR
 GROOVING • THREADING • PARTING • BORING
 TURNING • FACE GROOVING • SPECIALS
 FORM TOOLS • MILLING

KAISER TOOL COMPANY, INC.

Phone: 888-THINBIT (888-844-6248) or (260) 484-3620
 www.thinbit.com • Orders: orders@thinbit.com • Quotes: quotes@thinbit.com

TOOLING ORIENTATION GUIDE - BORING, PROFILING & TURNING

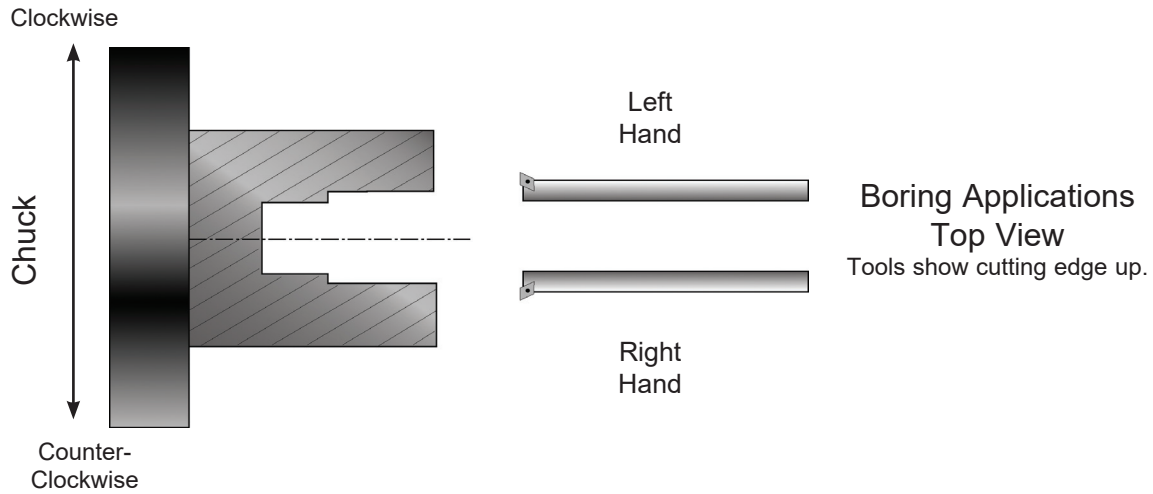

BORING

'K' ANGLE

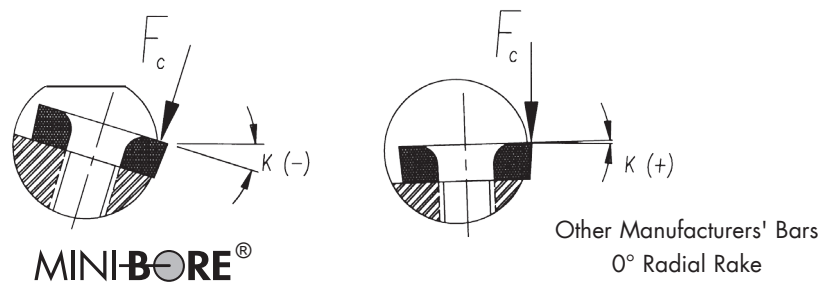

MINI-BORE[®] bars are designed to cut above center with a negative cutting rake or 'K' angle. As the diameter of the bar increases the 'K' angle decreases. Flats are provided to ensure speedy and proper set-up.

This unique design provides critical advantages over other manufacturers' small diameter bars:

- Up to 25% greater cross-sectional area under the cutting edge which increases the strength and rigidity of the pocket.
- Increased screw thread engagement to reduce thread stripping and increase the holding power.
- Better surface finishes due to better chip control and flow.

KAISER TOOL COMPANY, INC.

Phone: 888-THINBIT (888-844-6248) or (260) 484-3620
www.thinbit.com • Orders: orders@thinbit.com • Quotes: quotes@thinbit.com

MICROBIT®

PRODUCT INFORMATION

- For boring diameters .073" and larger.
- 1/8", 3/16", 1/4", 5/16", 3/8" and 1/2" shank.
- Elliptically ground necks for greater strength.
- Round necks to fit into small diameters.
- Sub-micron grain **DURA-MAX® 2000** Carbide.
- Tools available with TiN, TiAlN, TiCN and Diamond coating.

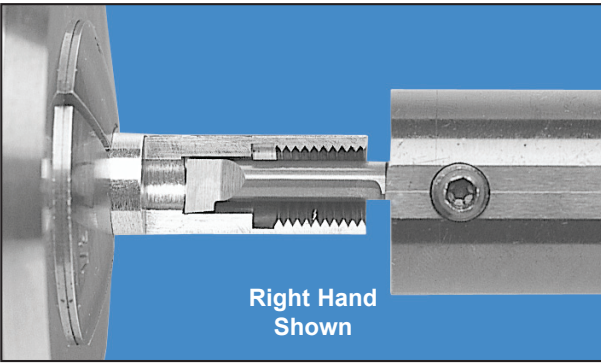

MODIFICATIONS
SEE PAGE 8-3 FOR ADDITIONAL INFORMATION

<p>CUSTOM BLANK (TOP VIEW)</p> <p>PG 8-6</p>	<p>RADII (TOP VIEW)</p>	<p>LEAD ANGLE (TOP VIEW)</p>	<p>BACK CLEARANCE (TOP VIEW)</p>
	<p>TOP RAKE (SIDE VIEW)</p>	<p>CHIP BREAKER (SIDE VIEW)</p>	<p>SIDE CLEARANCE (END VIEW)</p>

TOOLHOLDER SELECTIONS

ADAPTER STYLES

<p>PG 7-2</p>	<p>PG 7-2</p>
---------------	---------------

	SPEEDS AND FEEDS	APPLICATION REFERENCE	TROUBLESHOOTING
TECHNICAL SECTIONS	PG 9-15	PG 9-4	PG 9-7

KAISER TOOL COMPANY, INC.

Phone: 888-THINBIT (888-844-6248) or (260) 484-3620
 www.thinbit.com • Orders: orders@thinbit.com • Quotes: quotes@thinbit.com

BORING TOOLS

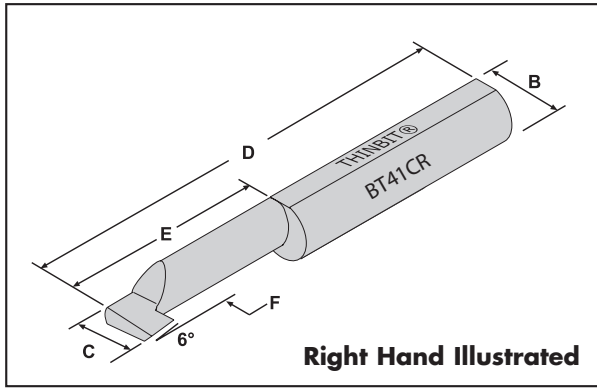

FRONT RAKE: Primary 21°
 BACK CLEARANCE: 3° Lead side
 SIDE CLEARANCE: 7° Lead side
 LEAD ANGLE: 6°
 RADIUS: None
 TOP RAKE: 0°
 NOTE: Tool designed for feeding into bore only.

ORDERING INSTRUCTIONS

Select the **ORDER CODE** in the table below that represents your selection of tool dimensions.

EXAMPLE:

The **ORDER CODE** for a .250" minimum bore, right hand tool with a .875" tool reach and .062" projection is:

BT41CR

TOOLS BORING



Specifications			Order Code				Information				
Minimum Bore	Tool Reach	Projection	DURA-MAX® 2000 Carbide See Page 9-15 for Speeds and Feeds		Coatings See Page 9-6 for expanded coating descriptions				Shank Diameter	Overall Length	Toolholder Page 7-2
'C'	'E'	'F'	Right Hand	Left Hand	Use uncoated part number and add coating code				'B'	'D'	Use Toolholders Beginning With
	Minimum	+ .000" / - .010"			TiN	TiCN	TiAlN	Diamond			
.073" Round Neck	.375"	.010"	BT20AR	BT20AL	add 'C'	add 'D'	add 'E'	add 'F'	1/8"	1.500"	'AD'
	.500"	.010"	BT21AR	BT21AL							
.125"	.500"	.031"	BT21CR	BT21CL							
.187"	.750"	.047"	BT31CR	BT31CL					3/16"	2.000"	'AD'
.250"	.875"	.062"	BT41CR	BT41CL					1/4"	2.500"	'AD'
.312"	1.156"	.078"	BT51CR	BT51CL					5/16"	2.500"	'AD'
.375"	1.437"	.125"	BT61CR	BT61CL					3/8"	3.000"	'AD'
.500"	2.000"	.167"	BT81CR	BT81CL					1/2"	3.500"	'AD'

KAISER TOOL COMPANY, INC.

Phone: 888-THINBIT (888-844-6248) or (260) 484-3620
 www.thinbit.com • Orders: orders@thinbit.com • Quotes: quotes@thinbit.com

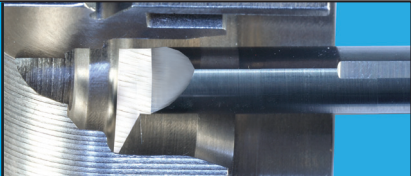
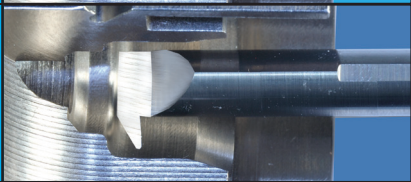
MICROBIT®

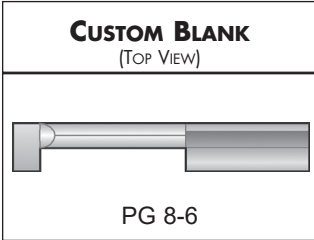
PRODUCT INFORMATION	<ul style="list-style-type: none"> • For profiling diameters .125" and larger. • 1/8", 3/16", 1/4", 5/16", 3/8" and 1/2" shank. • Elliptically ground necks for greater strength. • Sub-micron grain DURA-MAX® 2000 Carbide. • Tools available with TiN, TiAlN, TiCN and Diamond coating. 	Right Hand Profiling Tool Shown	
		Right Hand Reverse Profiling Tool Shown	

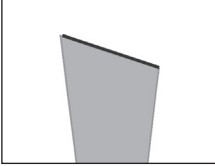
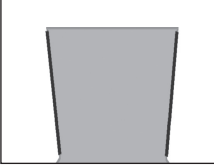
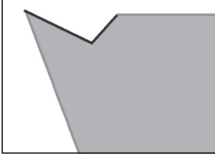
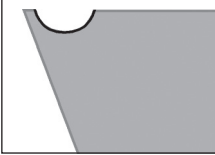
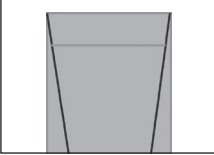
MODIFICATIONS SEE PAGE 8-3 FOR ADDITIONAL INFORMATION	CUSTOM BLANK (TOP VIEW)	RADI (TOP VIEW)	LEAD ANGLE (TOP VIEW)	BACK CLEARANCE (TOP VIEW)
	 PG 8-6			
		TOP RAKE (SIDE VIEW)	CHIP BREAKER (SIDE VIEW)	SIDE CLEARANCE (END VIEW)
				

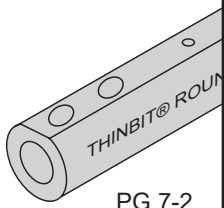
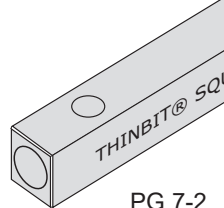
TOOLHOLDER SELECTIONS	ADAPTER STYLES	
	 PG 7-2	 PG 7-2

TECHNICAL SECTIONS	SPEEDS AND FEEDS	APPLICATION REFERENCE	TROUBLESHOOTING
	PG 9-15	PG 9-4	PG 9-7

ORDERING INSTRUCTIONS

Select the **ORDER CODE** in the table on the next page that represents your selection of tool dimensions.

EXAMPLE:

The **ORDER CODE** for a .375" minimum bore, right hand tool with a 1.350" tool reach and .115" projection is:

PT61CR

KAISER TOOL COMPANY, INC.

Phone: 888-THINBIT (888-844-6248) or (260) 484-3620
www.thinbit.com • Orders: orders@thinbit.com • Quotes: quotes@thinbit.com

PROFILING & REVERSE PROFILING TOOLS

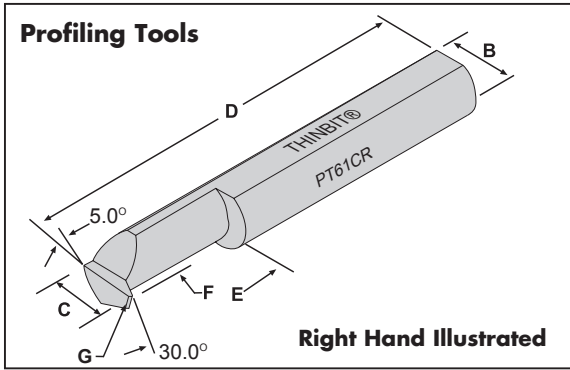

FRONT RAKE: Primary 21°
 SIDE CLEARANCE: 5° Lead side
 BACK CLEARANCE: 5° Lead side
 BACK CLEARANCE: 30° Trailing side
 NOTE: Tool designed for feeding into bore only.

SPECIFICATIONS				ORDER CODE				INFORMATION				
Minimum Bore	Tool Reach	Nose Radius	Projection	DURA-MAX® 2000 Carbide See Page 9-15 for Speeds and Feeds		Coatings See Page 9-6 for expanded coating descriptions				Shank Diameter	Overall Length	Toolholder Page 7-2
'C'	'E'	'G'	'F'	Right Hand	Left Hand	Use uncoated part number and add coating code				'B'	'D'	Use Toolholders Beginning With
	Minimum		Minimum			TiN	TiCN	TiAlN	Diamond			
.125"	.425"	.007"	.052"	PT21BR	PT21BL	add 'C'	add 'D'	add 'E'	add 'F'	1/8"	1.500"	'AD'
.187"	.705"	.010"	.083"	PT31BR	PT31BL					3/16"	2.000"	'AD'
.250"	.840"	.010"	.115"	PT41BR	PT41BL					1/4"	2.500"	'AD'
.312"	1.115"	.015"	.146"	PT51BR	PT51BL					5/16"	2.500"	'AD'
.375"	1.350"	.015"	.115"	PT61CR	PT61CL					3/8"	3.000"	'AD'
.500"	1.870"	.015"	.157"	PT81CR	PT81CL					1/2"	3.500"	'AD'

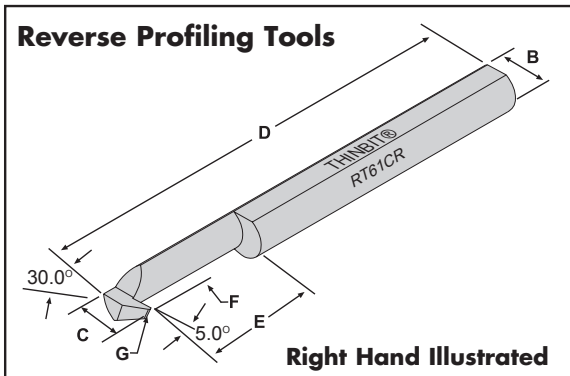

FRONT RAKE: Primary 21°
 SIDE CLEARANCE: 10° Lead side
 BACK CLEARANCE: 30° Lead side
 BACK CLEARANCE: 5° Trailing side
 NOTE: Tool designed for feeding out of bore only.

SPECIFICATIONS				ORDER CODE				INFORMATION				
Minimum Bore	Tool Reach	Nose Radius	Projection	DURA-MAX® 2000 Carbide See Page 9-15 for Speeds and Feeds		Coatings See Page 9-6 for expanded coating descriptions				Shank Diameter	Overall Length	Toolholder Page 7-2
'C'	'E'	'G'	'F'	Right Hand	Left Hand	Use uncoated part number and add coating code				'B'	'D'	Use Toolholders Beginning With
	Minimum		Minimum			TiN	TiCN	TiAlN	Diamond			
.125"	.375"	.007"	.052"	RT21BR	RT21BL	add 'C'	add 'D'	add 'E'	add 'F'	1/8"	1.500"	'AD'
.187"	.625"	.010"	.083"	RT31BR	RT31BL					3/16"	2.000"	'AD'
.250"	.750"	.010"	.115"	RT41BR	RT41BL					1/4"	2.500"	'AD'
.312"	1.000"	.015"	.146"	RT51BR	RT51BL					5/16"	2.500"	'AD'
.375"	1.250"	.015"	.115"	RT61CR	RT61CL					3/8"	3.000"	'AD'
.500"	1.750"	.015"	.157"	RT81CR	RT81CL					1/2"	3.500"	'AD'

KAISER TOOL COMPANY, INC.

Phone: 888-THINBIT (888-844-6248) or (260) 484-3620
 www.thinbit.com • Orders: orders@thinbit.com • Quotes: quotes@thinbit.com

PROFILING

MINIBORE® TRIGON®

PRODUCT INFORMATION

- Boring with .210" minimum bore diameter.
- 'K' angle increases strength in insert pocket by increasing the cross-sectional area below the insert.
- Boring bars for WCGT insert style.
- Variety of diameters made from Steel, Heavy Metal and Carbide.
- Bars and inserts are compatible with other ANSI standard bars and inserts. Call for cross-overs.
- Sub-micron grain **DURA-MAX® 4000** and **5000** Carbide.
- Tools available with TiN, TiAlN, TiCN and Diamond coating.
- Modifications can be provided on any of our tooling. Please contact us with your application requirements.

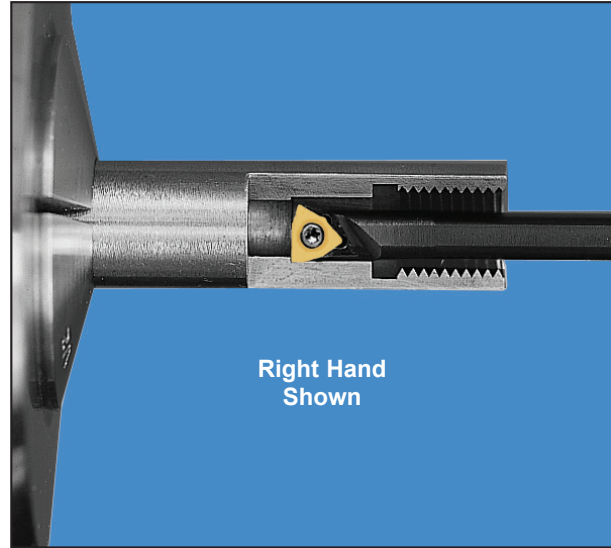

TOOLHOLDER SELECTIONS

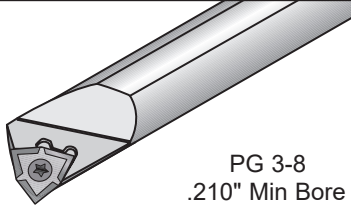
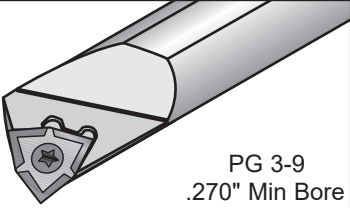
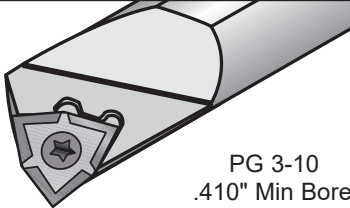
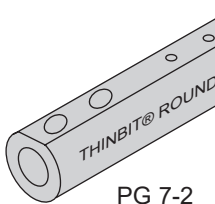
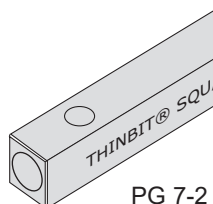
WCGT STYLE - MBE SERIES	WCGT STYLE - MBF SERIES	WCGT STYLE - MBG SERIES
 PG 3-8 .210" Min Bore	 PG 3-9 .270" Min Bore	 PG 3-10 .410" Min Bore
ADAPTER STYLES		
 PG 7-2		 PG 7-2

INSERT SELECTIONS

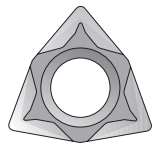
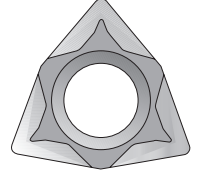
WCGT STYLE - MBE SERIES	WCGT STYLE - MBF SERIES	WCGT STYLE - MBG SERIES
 WCGT 1.21 PG 3-8	 WCGT 1.51.5 PG 3-9	 WCGT 21.5 PG 3-10

TECHNICAL SECTIONS

SPEEDS AND FEEDS	APPLICATION REFERENCE	TROUBLESHOOTING
PG 9-14	PG 9-4	PG 9-7

KAISER TOOL COMPANY, INC.

Phone: 888-THINBIT (888-844-6248) or (260) 484-3620
www.thinbit.com • Orders: orders@thinbit.com • Quotes: quotes@thinbit.com

TO ORDER WCGT STYLE - MBE SERIES BORING BARS

Select the **ORDER CODE** in the table below that represents your selection of tool specifications.

EXAMPLE:

The **ORDER CODE** for a .270" minimum bore, right hand, heavy metal shank with a 3° lead angle is:
MBEH132527R



 .156" I.C.	TOOL SPECIFICATIONS						ORDER CODE		
	Minimum Bore	Material	Bar Diameter	Length	Lead Angle	'K' Angle	Boring Bar Includes Screw and Wrench	Replacement Parts	
	'B' With .008" radius insert	Extension Ratios: Steel: 4 x ø Heavy Metal: 6 x ø Carbide: 8 x ø	'A'	'D'	'C'	'K' see page 3-2		Screw	Wrench
Right Hand Bars Use inserts beginning with 'MBEIW' and ANSI 'WCGT 1.21' inserts	.210"	Steel	.188"	3.500"	3°	17°	MBES131821R	F15	W11
		Heavy Metal	.188"	3.976"	3°	17°	MBEH131821R	F15	W11
		Carbide	.188"	4.474"	3°	17°	MBEC131821R	F15	W11
	.220"	Steel	.188"	3.500"	0°	17°	MBES101822R	F15	W11
		Heavy Metal	.188"	3.976"	0°	17°	MBEH101822R	F15	W11
	.270"	Steel	.250"	4.000"	0°	12°	MBES102527R	F15	W11
3°					12°	MBES132527R	F15	W11	
0°					12°	MBEH102527R	F15	W11	
	Heavy Metal	.250"	3.976"	3°	12°	MBEH132527R	F15	W11	

MBE TRIGON BORING

TO ORDER WCGT STYLE - MBE SERIES INSERTS

Select the **ORDER CODE** in the table below that represents your selection of insert specifications.

EXAMPLE:

The **ORDER CODE** for a **DURA-MAX® 4000** insert with .008" radius and TiN coating is:
MBEIW08D4C

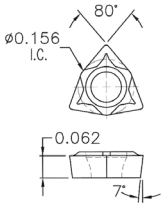
WCGT Style MBE Series Use toolholders beginning with 'MBE' 	SPECIFICATIONS		ORDER CODE			
	Insert Material	Corner Radius	Coating See Page 9-5 for expanded material description and Page 9-14 for speeds and feeds			
			Uncoated	TiN	TiCN Non-stock	TiAlN Non-stock
DURA-MAX® 4000 carbide For Steel & Interrupted Cutting	.004"	MBEIW04D4U	MBEIW04D4C	MBEIW04D4D	MBEIW04D4E	
	.008"	MBEIW08D4U	MBEIW08D4C	MBEIW08D4D	MBEIW08D4E	
	.015"	MBEIW15D4U	MBEIW15D4C	MBEIW15D4D	MBEIW15D4E	
DURA-MAX® 5000 carbide For Aluminum & Nonferrous	.004"	MBEIW04D5U	MBEIW04D5C	MBEIW04D5D	MBEIW04D5E	
	.008"	MBEIW08D5U	MBEIW08D5C	MBEIW08D5D	MBEIW08D5E	
	.015"	MBEIW15D5U	MBEIW15D5C	MBEIW15D5D	MBEIW15D5E	

KAISER TOOL COMPANY, INC.

Phone: 888-THINBIT (888-844-6248) or (260) 484-3620
www.thinbit.com • Orders: orders@thinbit.com • Quotes: quotes@thinbit.com

TO ORDER WCGT STYLE - MBF SERIES BORING BARS

Select the **ORDER CODE** in the table below that represents your selection of tool specifications.

EXAMPLE:

The **ORDER CODE** for a .330" minimum bore, right hand, heavy metal shank with a 0° lead angle is:
MBFH103133R

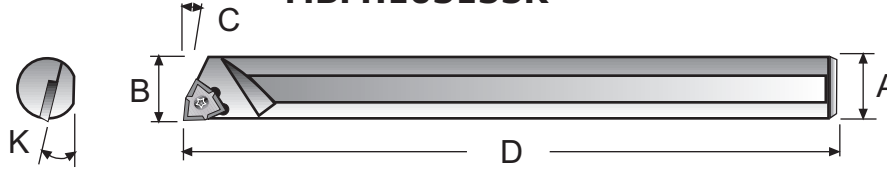

	TOOL SPECIFICATIONS						ORDER CODE		
	Minimum Bore 'B' With .008" radius insert	Material Extension Ratios: Steel: 4 x ø Heavy Metal: 6 x ø Carbide: 8 x ø	Bar Diameter 'A'	Length 'D'	Lead Angle 'C'	'K' Angle 'K' See Page 3-2	Boring Bar Includes Screw and Wrench	Replacement Parts Screw Wrench	
 .187" I.C. Right Hand Bars Use inserts beginning with 'MBFIW' and ANSI 'WCGT 1.51.5' inserts	.270"	Steel	.250"	4.000"	0°	15°	MBFS102527R	F15	W11
					3°	15°	MBFS132527R	F15	W11
		Heavy Metal	.250"	3.976"	0°	15°	MBFH102527R	F15	W11
					3°	15°	MBFH132527R	F15	W11
	.330"	Steel	.312"	4.000"	0°	15°	MBFS103133R	F15	W11
					3°	15°	MBFS133133R	F15	W11
		Heavy Metal	.312"	5.500"	0°	15°	MBFH103133R	F15	W11
					3°	15°	MBFH133133R	F15	W11
Left Hand Bars Use inserts beginning with 'MBFIW' and ANSI 'WCGT 1.51.5' inserts	.270"	Steel	.250"	4.000"	3°	15°	MBFS132527L	F15	W11
		Heavy Metal	.250"	3.976"	3°	15°	MBFH132527L	F15	W11
	.330"	Steel	.312"	4.000"	3°	15°	MBFS133133L	F15	W11
		Heavy Metal	.312"	5.500"	3°	15°	MBFH133133L	F15	W11

TO ORDER WCGT STYLE - MBF SERIES INSERTS

Select the **ORDER CODE** in the table below that represents your selection of insert specifications.

EXAMPLE:

The **ORDER CODE** for a **DURA-MAX® 4000** insert with .008" radius and TiN coating is:

MBFIW08D4C

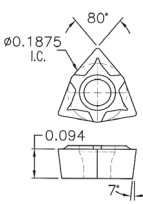
WCGT Style MBF Series Use toolholders beginning with 'MBF'	SPECIFICATIONS		ORDER CODE			
	Insert Material	Corner Radius	Coating See Page 9-5 for expanded material description and Page 9-14 for Speeds and Feeds			
			Uncoated	TiN	TiCN Non-stock	TiAlN Non-stock
	DURA-MAX® 4000 carbide For Steel & Interrupted Cutting	.004"	MBFIW04D4U	MBFIW04D4C	MBFIW04D4D	MBFIW04D4E
		.008"	MBFIW08D4U	MBFIW08D4C	MBFIW08D4D	MBFIW08D4E
		.015"	MBFIW15D4U	MBFIW15D4C	MBFIW15D4D	MBFIW15D4E
	DURA-MAX® 5000 carbide For Aluminum & Nonferrous	.004"	MBFIW04D5U	MBFIW04D5C	MBFIW04D5D	MBFIW04D5E
		.008"	MBFIW08D5U	MBFIW08D5C	MBFIW08D5D	MBFIW08D5E
		.015"	MBFIW15D5U	MBFIW15D5C	MBFIW15D5D	MBFIW15D5E

KAISER TOOL COMPANY, INC.

Phone: 888-THINBIT (888-844-6248) or (260) 484-3620
www.thinbit.com • Orders: orders@thinbit.com • Quotes: quotes@thinbit.com

TO ORDER WCGT STYLE - MBG SERIES BORING BARS

Select the **ORDER CODE** in the table below that represents your selection of tool specifications.

EXAMPLE:

The **ORDER CODE** for a .410" minimum bore, right hand, heavy metal shank with a 3° lead angle is:

MBGH133741R

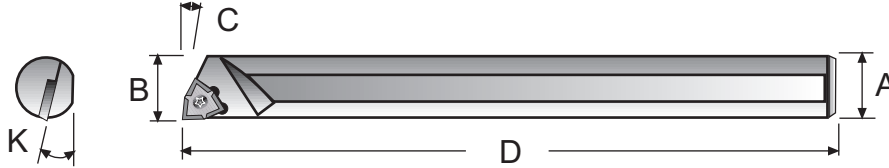

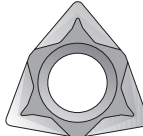
 .250" I.C.	TOOL SPECIFICATIONS						ORDER CODE		
	Minimum Bore 'B' <small>With .008" radius insert</small>	Material <small>Extension Ratios: Steel: 4 x ø Heavy Metal: 6 x ø Carbide: 8 x ø</small>	Bar Diameter 'A'	Length 'D'	Lead Angle 'C'	'K' Angle 'K' <small>See Page 3-2</small>	Boring Bar <small>Includes Screw and Wrench</small>	Replacement Parts <small>Screw Wrench</small>	
Right Hand Bars <small>Use inserts beginning with 'MBGIW' and ANSI 'WCGT 21.5' inserts</small>	.410"	Steel	.375"	5.500"	0°	8°	MBGS103741R	F26	W26
						3°	8°	MBGS133741R	F26
		Heavy Metal	.375"	5.500"	0°	8°	MBGH103741R	F26	W26
						3°	8°	MBGH133741R	F26
		Carbide	.375"	6.777"	3°	8°	MBGC133741R	F26	W26
	.530"	Steel	.500"	5.500"	0°	8°	MBGS105053R	F26	W26
						3°	8°	MBGS135053R	F26
		Heavy Metal	.500"	5.500"	0°	8°	MBGH105053R	F26	W26
					3°	8°	MBGH135053R	F26	W26
Left Hand Bars <small>Use inserts beginning with 'MBGIW' and ANSI 'WCGT 21.5' inserts</small>	.410"	Steel	.375"	5.500"	3°	8°	MBGS133741L	F26	W26
		Heavy Metal	.375"		5.500"	3°	8°	MBGH133741L	F26
	.530"	Steel	.500"	5.500"	3°	8°	MBGS135053L	F26	W26
		Heavy Metal	.500"		5.500"	3°	8°	MBGH135053L	F26

MBF & MBG TRIGON BORING

TO ORDER WCGT STYLE - MBG SERIES INSERTS

Select the **ORDER CODE** in the table below that represents your selection of insert specifications.

EXAMPLE:

The **ORDER CODE** for a **DURA-MAX® 4000** insert with .008" radius and TiN coating is:

MBGIW08D4C

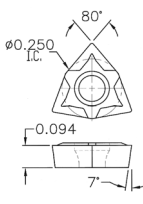
WCGT Style MBG Series Use toolholders beginning with 'MBG'	SPECIFICATIONS		ORDER CODE			
	Insert Material	Corner Radius	Coating <small>See Page 9-5 for expanded material description and Page 9-14 for Speeds and Feeds</small>			
			Uncoated	TiN	TiCN Non-stock	TiAlN Non-stock
	DURA-MAX® 4000 carbide <small>For Steel & Interrupted Cutting</small>	.004"	MBGIW04D4U	MBGIW04D4C	MBGIW04D4D	MBGIW04D4E
		.008"	MBGIW08D4U	MBGIW08D4C	MBGIW08D4D	MBGIW08D4E
		.015"	MBGIW15D4U	MBGIW15D4C	MBGIW15D4D	MBGIW15D4E
	DURA-MAX® 5000 carbide <small>For Aluminum & Nonferrous</small>	.004"	MBGIW04D5U	MBGIW04D5C	MBGIW04D5D	MBGIW04D5E
		.008"	MBGIW08D5U	MBGIW08D5C	MBGIW08D5D	MBGIW08D5E
		.015"	MBGIW15D5U	MBGIW15D5C	MBGIW15D5D	MBGIW15D5E

KAISER TOOL COMPANY, INC.

Phone: 888-THINBIT (888-844-6248) or (260) 484-3620
 www.thinbit.com • Orders: orders@thinbit.com • Quotes: quotes@thinbit.com

MINI-BORE®

PRODUCT INFORMATION

- Boring with .165" minimum bore diameter.
- 'K' angle increases strength in insert pocket by increasing the cross-sectional area below the insert.
- Boring bars for CD, TD and TP insert styles.
- Variety of diameters made from Steel, Heavy Metal and Carbide.
- Sub-micron grain **DURA-MAX® 3000, 4000 and 5000** Carbides.
- CBN tipped **DURA-MAX® 8000**.
- PCD tipped **DURA-MAX® 9000**.
- Inserts available with TiN, TiAlN, TiCN and Diamond coating.
- Bars and inserts are completely compatible with other ANSI standard bars and inserts. Call for cross-overs.
- Modifications can be provided on any of our tooling. Please contact us with your application requirements.

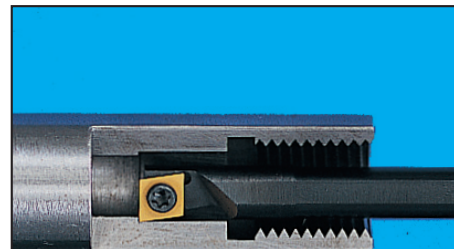

Right Hand Shown

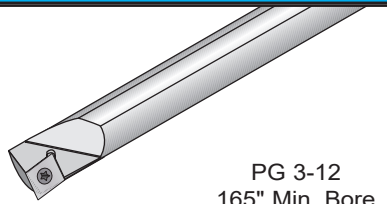
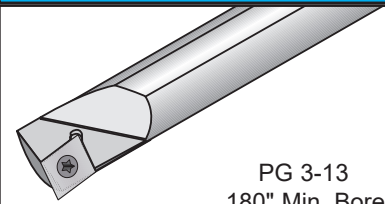
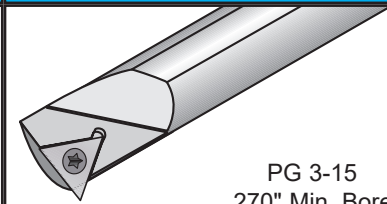
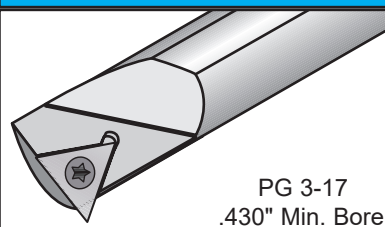
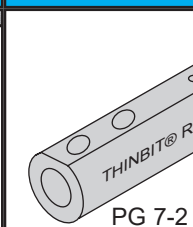
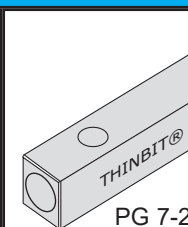
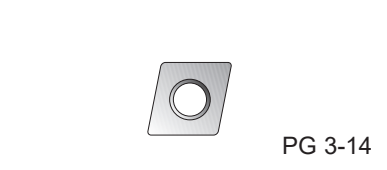
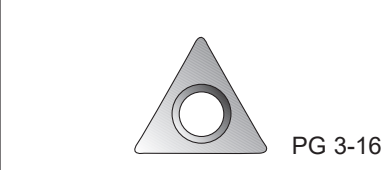
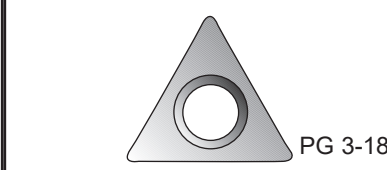
TOOLHOLDER SELECTIONS	CD STYLE - MBZ SERIES	CD STYLE - MBA SERIES	TD STYLE - MBB SERIES	
	 PG 3-12 .165" Min. Bore	 PG 3-13 .180" Min. Bore	 PG 3-15 .270" Min. Bore	
		TP STYLE - MBC SERIES	ADAPTER STYLES	
		 PG 3-17 .430" Min. Bore	 PG 7-2	 PG 7-2
INSERT SELECTIONS	CD STYLE - MBA SERIES	TD STYLE - MBB SERIES	TP STYLE - MBC SERIES	
	 PG 3-14	 PG 3-16	 PG 3-18	
TECHNICAL SECTIONS	SPEEDS AND FEEDS	APPLICATION REFERENCE	TROUBLESHOOTING	
	PG 9-15	PG 9-4	PG 9-7	

KAISER TOOL COMPANY, INC.

Phone: 888-THINBIT (888-844-6248) or (260) 484-3620
www.thinbit.com • Orders: orders@thinbit.com • Quotes: quotes@thinbit.com

TO ORDER CD STYLE - MBZ SERIES BORING BARS

Select the **ORDER CODE** in the table below that represents your selection of tool specifications.

EXAMPLE:

The **ORDER CODE** for a .165" minimum bore, right hand, steel, .187" shank is:
MBZS171816R

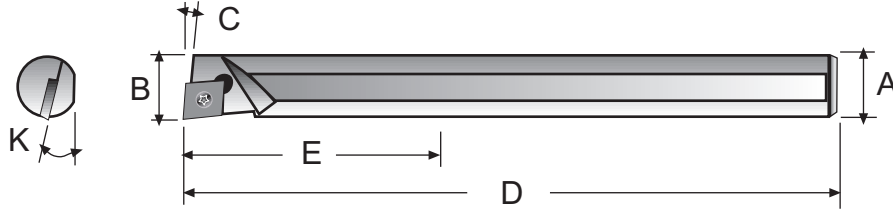

	TOOL SPECIFICATIONS							ORDER CODE		
	Minimum Bore 'B' <small>With .007" radius insert</small>	Material <small>Extension Ratios: Steel: 4 x ø Carbide: 8 x ø</small>	Bar Diameter 'A'	Length 'D'	Neck Length 'E'	Lead Angle 'C'	'K' Angle 'K'	Boring Bar <small>Includes Screw and Wrench</small>	Replacement Parts <small>Screw Wrench</small>	
 .140" I.C. Right Hand Bars Use inserts beginning with 'MBZIZ'	0.165"	Steel	.187"	2.500"	.580"	7°	17°	MBZS171816R	F11	W11
		Carbide	.156"	4.477"	1.500"	7°	17°	MBZC171516R		

MBZ BARS & INSERTS BORING

TO ORDER CDCD STYLE - MBZ SERIES INSERTS

Select the **ORDER CODE** in the table below that represents your selection of insert specifications.

EXAMPLE:

The **ORDER CODE** for a **DURA-MAX® 5000** insert with .007" radius and TiN coating is:
MBZIZ07D5C

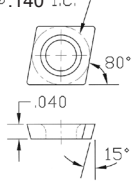
MBZ Series Use toolholders beginning with 'MBZ'	SPECIFICATIONS		ORDER CODE				
	Insert Material	Corner Radius	Coating <small>See Page 9-5 for expanded material description and Page 9-15 for speeds and feeds</small>				
			Uncoated	TiN	TiCN Non-stock	TiAlN Non-stock	Diamond Non-stock
	DURA-MAX® 4000 carbide For Steel & Interrupted Cutting	.002"	MBZIZ02D4U	MBZIZ02D4C	MBZIZ02D4D	MBZIZ02D4E	MBZIZ02D4F
		.007"	MBZIZ07D4U	MBZIZ07D4C	MBZIZ07D4D	MBZIZ07D4E	MBZIZ07D4F
		.015"	MBZIZ15D4U	MBZIZ15D4C	MBZIZ15D4D	MBZIZ15D4E	MBZIZ15D4F
	DURA-MAX® 5000 carbide For Aluminum & Nonferrous	.002"	MBZIZ02D5U	MBZIZ02D5C	MBZIZ02D5D	MBZIZ02D5E	MBZIZ02D5F
		.007"	MBZIZ07D5U	MBZIZ07D5C	MBZIZ07D5D	MBZIZ07D5E	MBZIZ07D5F
		.015"	MBZIZ15D5U	MBZIZ15D5C	MBZIZ15D5D	MBZIZ15D5E	MBZIZ15D5F

KAISER TOOL COMPANY, INC.

Phone: 888-THINBIT (888-844-6248) or (260) 484-3620
 www.thinbit.com • Orders: orders@thinbit.com • Quotes: quotes@thinbit.com

TO ORDER CD STYLE - MBA SERIES BORING BARS

Select the **ORDER CODE** in the table below that represents your selection of tool specifications.

EXAMPLE:

The **ORDER CODE** for a .205" minimum bore, right hand, steel, .187" shank is:

MBAS151820R

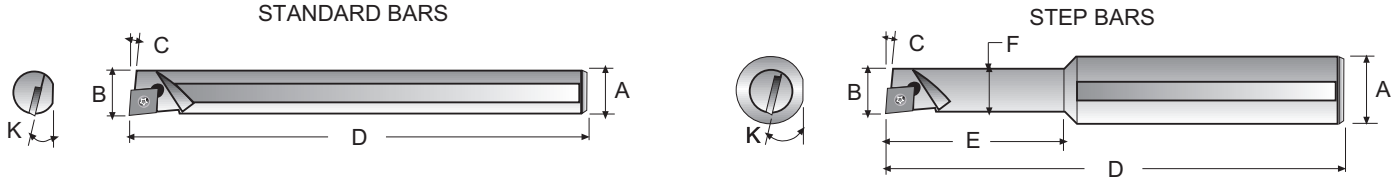

 .156" I.C.	TOOL SPECIFICATIONS								ORDER CODE		
	Minimum Bore 'B'	Material	Bar Diameter		Length		Lead Angle	'K' Angle	Boring Bar	Replacement Parts	
			'F' Neck	'A' Shank	'E' Neck	'D' Overall	'C'	'K'		Includes Screw and Wrench	Screw
Right Hand Bars Use inserts beginning with 'MBAIW', 'MBAIZ', left hand 'MBAIG' inserts and most ANSI 'CD' standard inserts	.180"	Steel	.164"	.187"	.520"	2.500"	7°	17°	MBAS171818R	F11	W11
			.164"	.375"	.500"	2.500"	7°	17°	MBAS373718R050		
		Heavy Metal	.156"		---	3.976"	7°	17°	MBAH171518R		
			.164"	.500"	.750"	3.000"	7°	17°	MBAH375018R075		
		Carbide	.156"		---	4.477"	7°	17°	MBAC171518R		
	.205"	Steel	.187"		---	3.500"	5°	17°	MBAS151820R	F15	W11
			.180"	.500"	.500"	3.000"	5°	17°	MBAS355020R050		
		Heavy Metal	.187"		---	3.976"	5°	17°	MBAH151820R		
	.210"	Steel	.187"		---	3.500"	0°	17°	MBAS101821R	F15	W11
			.187"	.375"	1.000"	3.000"	5°	17°	MBAS353721R100		
		Heavy Metal	.187"		---	3.976"	0°	17°	MBAH101821R		
	.220"	Steel	.197"	.375"	.500"	2.500"	0°	17°	MBAS303722R050	F15	W11
		Heavy Metal	.187"		---	3.976"	5°	17°	MBAH151822R		
			.187"	.500"	1.125"	3.977"	5°	17°	MBAH355022R112		
		Carbide	.187"		---	4.477"	5°	17°	MBAC151822R		
	.230"	Steel	.187"		---	3.500"	5°	17°	MBAS151823R	F15	W11
	.270"	Steel	.250"		---	4.000"	0°	12°	MBAS102527R	F15	W11
	.280"	Steel	.250"		---	4.000"	5°	12°	MBAS152528R	F15	W11
		.250"	.375"	1.250"	3.000"	5°	12°	MBAS353728R125			
Heavy Metal		.250"		---	3.976"	5°	12°	MBAH152528R			
	Carbide	.250"		---	6.504"	5°	12°	MBAC152528R			
.350"	Heavy Metal	.313"		---	5.500"	5°	8°	MBAH153135R	F15	W11	
Left Hand Bars Use inserts beginning with 'MBAIW', 'MBAIZ', right hand 'MBAIG' inserts and most ANSI 'CD' standard inserts	.180"	Steel	.164"	.187"	.520"	2.500"	7°	17°	MBAS171818L	F11	W11
		Heavy Metal	.156"		---	3.976"	7°	17°	MBAH171518L		
	.205"	Steel	.180"	.500"	.500"	3.000"	5°	17°	MBAS355020L050	F15	W11
	.230"	Steel	.187"		---	3.500"	5°	17°	MBAS151823L		
.280"	Steel	.250"		---	4.000"	5°	12°	MBAS152528L			

KAISER TOOL COMPANY, INC.





Phone: 888-THINBIT (888-844-6248) or (260) 484-3620
 www.thinbit.com • Orders: orders@thinbit.com • Quotes: quotes@thinbit.com

TO ORDER CD STYLE - MBA SERIES INSERTS

Select the **ORDER CODE** in the table below that represents your selection of insert specifications.

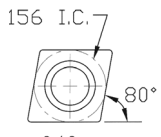
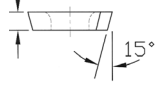
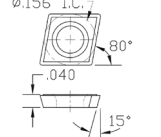
EXAMPLE:

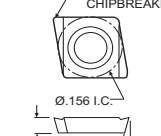
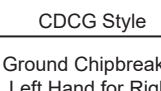
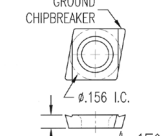
The **ORDER CODE** for a molded chipbreaker, **DURA-MAX® 4000** insert with .007" radius and TiN coating is:
MBAIW07D4C

CD Style MBA Series Use toolholders beginning with 'MBA'	SPECIFICATIONS		ORDER CODE					
	Insert Material	Corner Radius	Coating <small>See Page 9-5 for expanded material descriptions and Page 9-15 for Speeds and Feeds</small>					
			Uncoated	TiN	TiCN Non-stock	TiAlN Non-stock	Diamond Non-stock	
Flat top   CDCD Style	DURA-MAX® 4000 Carbide For Steel & Interrupted Cutting	.002"	MBAIZ02D4U	MBAIZ02D4C	MBAIZ02D4D	MBAIZ02D4E	MBAIZ02D4F	
		.007"	MBAIZ07D4U	MBAIZ07D4C	MBAIZ07D4D	MBAIZ07D4E	MBAIZ07D4F	
		.015"	MBAIZ15D4U	MBAIZ15D4C	MBAIZ15D4D	MBAIZ15D4E	MBAIZ15D4F	
	DURA-MAX® 5000 Carbide For Aluminum & Nonferrous	.002"	MBAIZ02D5U	MBAIZ02D5C	MBAIZ02D5D	MBAIZ02D5E	MBAIZ02D5F	
		.007"	MBAIZ07D5U	MBAIZ07D5C	MBAIZ07D5D	MBAIZ07D5E	MBAIZ07D5F	
		.015"	MBAIZ15D5U	MBAIZ15D5C	MBAIZ15D5D	MBAIZ15D5E	MBAIZ15D5F	
	DURA-MAX® 8000 CBN For Hardened Materials	.002"	MBAIZ02D8					
		.007"	MBAIZ07D8					
		.015"	MBAIZ15D8					
	DURA-MAX® 9000 PCD For Abrasive Nonferrous	.002"	MBAIZ02D9					
		.007"	MBAIZ07D9					
		.015"	MBAIZ15D9					
	Molded Chipbreaker   CDCH Style	DURA-MAX® 4000 Carbide For Steel & Interrupted Cutting	.007"	MBAIW07D4U	MBAIW07D4C	MBAIW07D4D	MBAIW07D4E	MBAIW07D4F
.015"			MBAIW15D4U	MBAIW15D4C	MBAIW15D4D	MBAIW15D4E	MBAIW15D4F	
DURA-MAX® 5000 Carbide For Aluminum & Nonferrous		.007"	MBAIW07D5U	MBAIW07D5C	MBAIW07D5D	MBAIW07D5E	MBAIW07D5F	
		.015"	MBAIW15D5U	MBAIW15D5C	MBAIW15D5D	MBAIW15D5E	MBAIW15D5F	
Ground Chipbreaker Right Hand for Left Hand Bars   CDCG Style		DURA-MAX® 4000 Carbide For Steel & Interrupted Cutting	.002"	MBAIG02D4UR	MBAIG02D4CR	MBAIG02D4DR	MBAIG02D4ER	MBAIG02D4FR
			.007"	MBAIG07D4UR	MBAIG07D4CR	MBAIG07D4DR	MBAIG07D4ER	MBAIG07D4FR
	.015"		MBAIG15D4UR	MBAIG15D4CR	MBAIG15D4DR	MBAIG15D4ER	MBAIG15D4FR	
	DURA-MAX® 5000 Carbide For Aluminum & Nonferrous	.002"	MBAIG02D5UR	MBAIG02D5CR	MBAIG02D5DR	MBAIG02D5ER	MBAIG02D5FR	
		.007"	MBAIG07D5UR	MBAIG07D5CR	MBAIG07D5DR	MBAIG07D5ER	MBAIG07D5FR	
		.015"	MBAIG15D5UR	MBAIG15D5CR	MBAIG15D5DR	MBAIG15D5ER	MBAIG15D5FR	
Ground Chipbreaker Left Hand for Right Hand Bars   CDCG Style	DURA-MAX® 4000 Carbide For Steel & Interrupted Cutting	.002"	MBAIG02D4UL	MBAIG02D4CL	MBAIG02D4DL	MBAIG02D4EL	MBAIG02D4FL	
		.007"	MBAIG07D4UL	MBAIG07D4CL	MBAIG07D4DL	MBAIG07D4EL	MBAIG07D4FL	
		.015"	MBAIG15D4UL	MBAIG15D4CL	MBAIG15D4DL	MBAIG15D4EL	MBAIG15D4FL	
	DURA-MAX® 5000 Carbide For Aluminum & Nonferrous	.002"	MBAIG02D5UL	MBAIG02D5CL	MBAIG02D5DL	MBAIG02D5EL	MBAIG02D5FL	
		.007"	MBAIG07D5UL	MBAIG07D5CL	MBAIG07D5DL	MBAIG07D5EL	MBAIG07D5FL	
		.015"	MBAIG15D5UL	MBAIG15D5CL	MBAIG15D5DL	MBAIG15D5EL	MBAIG15D5FL	

**MBA BARS
& INSERTS
BORING**

KAISER TOOL COMPANY, INC.

Phone: 888-THINBIT (888-844-6248) or (260) 484-3620
www.thinbit.com • Orders: orders@thinbit.com • Quotes: quotes@thinbit.com

TO ORDER TD STYLE - MBB SERIES BORING BARS

Select the **ORDER CODE** in the table below that represents your selection of tool specifications.

EXAMPLE:

The **ORDER CODE** for a .300" minimum bore, right hand, heavy metal, .500" shank step bar is:

MBBH355030R150

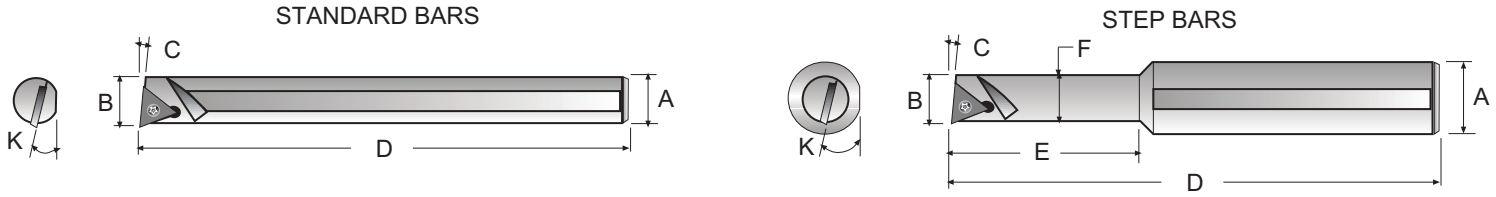

 .160" I.C.	TOOL SPECIFICATIONS							ORDER CODE						
	Minimum Bore 'B'	Material	Bar Diameter		Length		Lead Angle 'C'	'K' Angle 'K'	Boring Bar	Replacement Parts				
			'F' Neck	'A' Shank	'E' Neck	'D' Overall				Includes Screw and Wrench	Screw	Wrench		
Right Hand Bars Use inserts beginning with 'MBBIW', 'MBBIZ', left hand 'MBBIG' inserts and most ANSI 'TD' standard inserts	.270"	Steel	.187"		---	3.500"	0°	17°	MBBS101827R	F22	W11			
			.187"		---	3.500"	5°	17°	MBBS151827R					
			.187"	.500"	1.000"	3.000"	5°	17°	MBBS355027R100					
		Heavy Metal	.187"		---	3.976"	0°	17°	MBBH101827R					
			.187"		---	3.976"	5°	17°	MBBH151827R					
			.187"	.500"	1.125"	3.965"	5°	17°	MBBH355027R112					
	Carbide	.187"		---	4.487"	5°	17°	MBBC151827R						
	.300"	Steel	.250"		---	4.000"	0°	12°	MBBS102530R	F22	W11			
			.250"		---	4.000"	5°	12°	MBBS152530R					
			.250"	.500"	1.250"	3.000"	5°	12°	MBBS355030R125					
			.250"	.625"	1.250"	4.000"	5°	12°	MBBS356230R125					
			Heavy Metal	.250"		---	3.976"	0°	12°			MBBH102530R		
				.250"		---	3.976"	5°	12°			MBBH152530R		
		.250"		.500"	1.500"	3.981"	5°	12°	MBBH355030R150					
		Carbide	.250"		---	6.488"	5°	12°	MBBC152530R					
		.350"	Steel	.313"		---	4.000"	0°	8°			MBBS103135R	F22	W11
				.313"		---	4.000"	5°	8°			MBBS153135R		
				.313"	.500"	1.000"	3.000"	5°	8°			MBBS355035R100		
			Heavy Metal	.313"		---	5.500"	0°	8°			MBBH103135R		
	.313"			---	5.500"	5°	8°	MBBH153135R						
	.313"			.500"	1.500"	3.981"	5°	8°	MBBH355035R150					
	Carbide	.313"		---	6.483"	5°	8°	MBBC153135R						
	Left Hand Bars	.270"	Steel	.187"		---	3.500"	5°	17°	MBBS151827L	F22	W11		
		.300"	Steel	.250"		---	4.000"	5°	12°	MBBS152530L				
.350"		Steel	.313"		---	4.000"	5°	8°	MBBS153135L					
		Heavy Metal	.313"		---	5.500"	5°	8°	MBBH153135L					

KAISER TOOL COMPANY, INC.



Phone: 888-THINBIT (888-844-6248) or (260) 484-3620
 www.thinbit.com • Orders: orders@thinbit.com • Quotes: quotes@thinbit.com

TO ORDER TD STYLE - MBB SERIES INSERTS

Select the **ORDER CODE** in the table below that represents your selection of insert specifications.

EXAMPLE:

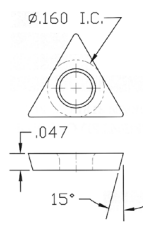
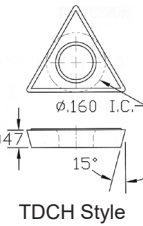
The **ORDER CODE** for a molded chipbreaker, **DURA-MAX® 4000** insert with .007" radius and TiN coating is:
MBBIW07D4C

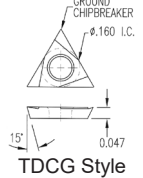
TD Style MBB Series Use toolholders beginning with 'MBB'	SPECIFICATIONS		ORDER CODE				
	Insert Material	Corner Radius	Coating <small>See Page 9-5 for expanded material descriptions and Page 9-15 for Speeds and Feeds</small>				
			Uncoated	TiN	TiCN Non-stock	TiAlN Non-stock	Diamond Non-stock
Flat top  TDAB Style	DURA-MAX® 3000/4000 Carbide* For Steel & Interrupted Cutting	.002"	MBBIZ02D3U	MBBIZ02D3C	MBBIZ02D3D	MBBIZ02D3E	MBBIZ02D3F
		.007"	MBBIZ07D3U	MBBIZ07D3C	MBBIZ07D3D	MBBIZ07D3E	MBBIZ07D3F
		.015"	MBBIZ15D3U	MBBIZ15D3C	MBBIZ15D3D	MBBIZ15D3E	MBBIZ15D3F
		.031"	MBBIZ31D3U	MBBIZ31D3C	MBBIZ31D3D	MBBIZ31D3E	MBBIZ31D3F
	DURA-MAX® 5000 Carbide For Aluminum & Nonferrous	.002"	MBBIZ02D5U	MBBIZ02D5C	MBBIZ02D5D	MBBIZ02D5E	MBBIZ02D5F
		.007"	MBBIZ07D5U	MBBIZ07D5C	MBBIZ07D5D	MBBIZ07D5E	MBBIZ07D5F
		.015"	MBBIZ15D5U	MBBIZ15D5C	MBBIZ15D5D	MBBIZ15D5E	MBBIZ15D5F
		.031"	MBBIZ31D5U	MBBIZ31D5C	MBBIZ31D5D	MBBIZ31D5E	MBBIZ31D5F
	DURA-MAX® 8000 CBN For Hardened Materials	.002"	MBBIZ02D8				
		.007"	MBBIZ07D8				
		.015"	MBBIZ15D8				
		.031"	MBBIZ31D8				
	DURA-MAX® 9000 PCD For Abrasive Nonferrous	.002"	MBBIZ02D9				
		.007"	MBBIZ07D9				
		.015"	MBBIZ15D9				
		.031"	MBBIZ31D9				
Molded Chipbreaker  TDCH Style	DURA-MAX® 4000 Carbide For Steel & Interrupted Cutting	.007"	MBBIW07D4U	MBBIW07D4C	MBBIW07D4D	MBBIW07D4E	MBBIW07D4F
		.015"	MBBIW15D4U	MBBIW15D4C	MBBIW15D4D	MBBIW15D4E	MBBIW15D4F
	DURA-MAX® 5000 Carbide For Aluminum & Nonferrous	.007"	MBBIW07D5U	MBBIW07D5C	MBBIW07D5D	MBBIW07D5E	MBBIW07D5F
		.015"	MBBIW15D5U	MBBIW15D5C	MBBIW15D5D	MBBIW15D5E	MBBIW15D5F
Ground Chipbreaker Right Hand for Left Hand Bars  TDCG Style	DURA-MAX® 3000 Carbide For Steel & Interrupted Cutting	.002"	MBBIG02D3UR	MBBIG02D3CR	MBBIG02D3DR	MBBIG02D3ER	MBBIG02D3FR
		.007"	MBBIG07D3UR	MBBIG07D3CR	MBBIG07D3DR	MBBIG07D3ER	MBBIG07D3FR
		.015"	MBBIG15D3UR	MBBIG15D3CR	MBBIG15D3DR	MBBIG15D3ER	MBBIG15D3FR
		.031"	MBBIG31D3UR	MBBIG31D3CR	MBBIG31D3DR	MBBIG31D3ER	MBBIG31D3FR
	DURA-MAX® 5000 Carbide For Aluminum & Nonferrous	.002"	MBBIG02D5UR	MBBIG02D5CR	MBBIG02D5DR	MBBIG02D5ER	MBBIG02D5FR
		.007"	MBBIG07D5UR	MBBIG07D5CR	MBBIG07D5DR	MBBIG07D5ER	MBBIG07D5FR
		.015"	MBBIG15D5UR	MBBIG15D5CR	MBBIG15D5DR	MBBIG15D5ER	MBBIG15D5FR
		.031"	MBBIG31D5UR	MBBIG31D5CR	MBBIG31D5DR	MBBIG31D5ER	MBBIG31D5FR
Ground Chipbreaker Left Hand for Right Hand Bars  TDCG Style	DURA-MAX® 3000 Carbide For Steel & Interrupted Cutting	.002"	MBBIG02D3UL	MBBIG02D3CL	MBBIG02D3DL	MBBIG02D3EL	MBBIG02D3FL
		.007"	MBBIG07D3UL	MBBIG07D3CL	MBBIG07D3DL	MBBIG07D3EL	MBBIG07D3FL
		.015"	MBBIG15D3UL	MBBIG15D3CL	MBBIG15D3DL	MBBIG15D3EL	MBBIG15D3FL
		.031"	MBBIG31D3UL	MBBIG31D3CL	MBBIG31D3DL	MBBIG31D3EL	MBBIG31D3FL
	DURA-MAX® 5000 Carbide For Aluminum & Nonferrous	.002"	MBBIG02D5UL	MBBIG02D5CL	MBBIG02D5DL	MBBIG02D5EL	MBBIG02D5FL
		.007"	MBBIG07D5UL	MBBIG07D5CL	MBBIG07D5DL	MBBIG07D5EL	MBBIG07D5FL
		.015"	MBBIG15D5UL	MBBIG15D5CL	MBBIG15D5DL	MBBIG15D5EL	MBBIG15D5FL
		.031"	MBBIG31D5UL	MBBIG31D5CL	MBBIG31D5DL	MBBIG31D5EL	MBBIG31D5FL

**MBB BARS
& INSERTS
BORING**

* For some details, **DURA-MAX® 4000** may be substituted.

KAISER TOOL COMPANY, INC.

Phone: 888-THINBIT (888-844-6248) or (260) 484-3620
www.thinbit.com • Orders: orders@thinbit.com • Quotes: quotes@thinbit.com

TO ORDER TP STYLE - MBC SERIES BORING BARS

Select the **ORDER CODE** in the table below that represents your selection of tool specifications.

EXAMPLE:

The **ORDER CODE** for a .430" minimum bore, right hand, steel, .375" shank is:

MBCS153743R

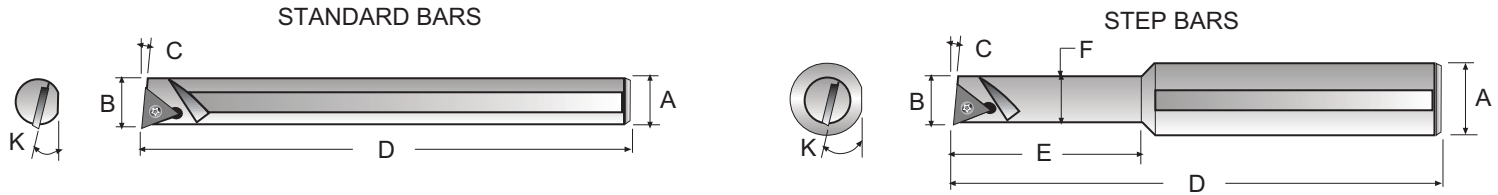

 .250" I.C.	TOOL SPECIFICATIONS							ORDER CODE			
	Minimum Bore 'B'	Material	Bar Diameter		Length		Lead Angle 'C'	'K' Angle 'K'	Boring Bar	Replacement Parts	
			'F'	'A'	'E'	'D'				Includes Screw and Wrench	Screw
Right Hand Bars Use inserts beginning with 'MBCIW', 'MBCIZ', left hand 'MBCIG' inserts and most ANSI 'TP' standard inserts	.430"	Steel	.375"		---	5.500"	0°	8°	MBCS103743R	F31	W31
			.375"		---	5.500"	5°	8°	MBCS153743R		
			.375"	.750"	1.125"	4.000"	5°	8°	MBCS357543R112		
		Heavy Metal	.375"		---	5.500"	5°	8°	MBCH153743R		
			.375"	.500"	2.250"	3.988"	5°	8°	MBCH355043R225		
	Carbide	.375"		---	6.783"	5°	8°	MBCC153743R			
	.560"	Steel	.500"		---	5.500"	5°	2°	MBCS155056R	F31	W31
			.500"	.625"	1.500"	4.000"	5°	2°	MBCS356256R150		
		Heavy Metal	.500"		---	5.500"	5°	2°	MBCH155056R		
	Carbide	.500"		---	6.769"	5°	2°	MBCC155056R			
.680"	Steel	.625"		---	5.500"	5°	2°	MBCS156268R	F31	W31	
Left Hand Bars Use inserts beginning with 'MBCIW', 'MBCIZ', right hand 'MBCIG' inserts and most ANSI 'TP' standard inserts	.430"	Steel	.375"		---	5.500"	5°	8°	MBCS153743L	F31	W31

KAISER TOOL COMPANY, INC.

Phone: 888-THINBIT (888-844-6248) or (260) 484-3620
 www.thinbit.com • Orders: orders@thinbit.com • Quotes: quotes@thinbit.com

TO ORDER TP STYLE - MBC SERIES INSERTS

Select the **ORDER CODE** in the table below that represents your selection of insert specifications.

EXAMPLE:

The **ORDER CODE** for a molded chipbreaker, **DURA-MAX® 5000** insert with .015" radius and TiN coating is:
MBCIW15D5C

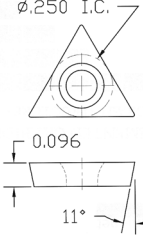
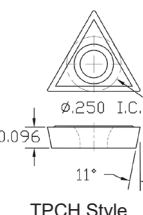
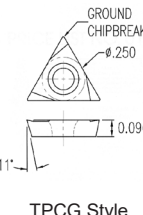
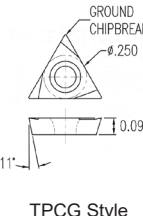
TP Style MBC Series Use toolholders beginning with 'MBC'	SPECIFICATIONS		ORDER CODE					
	Insert Material	Corner Radius	Coating <small>See Page 9-5 for expanded material descriptions and Page 9-15 for Speeds and Feeds</small>					
			Uncoated	TiN	TiCN Non-stock	TiAlN Non-stock	Diamond Non-stock	
Flat top  TPCB Style	DURA-MAX® 3000/4000 Carbide* For Steel & Interrupted Cutting	.002"	MBCIZ02D3U	MBCIZ02D3C	MBCIZ02D3D	MBCIZ02D3E	MBCIZ02D3F	
		.007"	MBCIZ07D3U	MBCIZ07D3C	MBCIZ07D3D	MBCIZ07D3E	MBCIZ07D3F	
		.015"	MBCIZ15D4U	MBCIZ15D4C	MBCIZ15D4D	MBCIZ15D4E	MBCIZ15D4F	
		.031"	MBCIZ31D3U	MBCIZ31D3C	MBCIZ31D3D	MBCIZ31D3E	MBCIZ31D3F	
	DURA-MAX® 5000 Carbide For Aluminum & Nonferrous	.002"	MBCIZ02D5U	MBCIZ02D5C	MBCIZ02D5D	MBCIZ02D5E	MBCIZ02D5F	
		.007"	MBCIZ07D5U	MBCIZ07D5C	MBCIZ07D5D	MBCIZ07D5E	MBCIZ07D5F	
		.015"	MBCIZ15D5U	MBCIZ15D5C	MBCIZ15D5D	MBCIZ15D5E	MBCIZ15D5F	
		.031"	MBCIZ31D5U	MBCIZ31D5C	MBCIZ31D5D	MBCIZ31D5E	MBCIZ31D5F	
	DURA-MAX® 8000 CBN For Hardened Materials	.002"	MBCIZ02D8					
		.007"	MBCIZ07D8					
		.015"	MBCIZ15D8					
		.031"	MBCIZ31D8					
	DURA-MAX® 9000 PCD For Abrasive Nonferrous	.002"	MBCIZ02D9					
		.007"	MBCIZ07D9					
		.015"	MBCIZ15D9					
		.031"	MBCIZ31D9					
Molded Chipbreaker  TPCH Style	DURA-MAX® 3000 Carbide* For Steel & Interrupted Cutting	.015"	MBCIW15D3U	MBCIW15D3C	MBCIW15D3D	MBCIW15D3E	MBCIW15D3F	
		.031"	MBCIW31D3U	MBCIW31D3C	MBCIW31D3D	MBCIW31D3E	MBCIW31D3F	
	DURA-MAX® 5000 Carbide For Aluminum & Nonferrous	.015"	MBCIW15D5U	MBCIW15D5C	MBCIW15D5D	MBCIW15D5E	MBCIW15D5F	
		.031"	MBCIW31D5U	MBCIW31D5C	MBCIW31D5D	MBCIW31D5E	MBCIW31D5F	
Ground Chipbreaker Right Hand for Left Hand Bars  TPCG Style	DURA-MAX® 3000/4000 Carbide* For Steel & Interrupted Cutting	.002"	MBCIG02D3UR	MBCIG02D3CR	MBCIG02D3DR	MBCIG02D3ER	MBCIG02D3FR	
		.007"	MBCIG07D3UR	MBCIG07D3CR	MBCIG07D3DR	MBCIG07D3ER	MBCIG07D3FR	
		.015"	MBCIG15D4UR	MBCIG15D4CR	MBCIG15D4DR	MBCIG15D4ER	MBCIG15D4FR	
		.031"	MBCIG31D3UR	MBCIG31D3CR	MBCIG31D3DR	MBCIG31D3ER	MBCIG31D3FR	
	DURA-MAX® 5000 Carbide For Aluminum & Nonferrous	.002"	MBCIG02D5UR	MBCIG02D5CR	MBCIG02D5DR	MBCIG02D5ER	MBCIG02D5FR	
		.007"	MBCIG07D5UR	MBCIG07D5CR	MBCIG07D5DR	MBCIG07D5ER	MBCIG07D5FR	
		.015"	MBCIG15D5UR	MBCIG15D5CR	MBCIG15D5DR	MBCIG15D5ER	MBCIG15D5FR	
		.031"	MBCIG31D5UR	MBCIG31D5CR	MBCIG31D5DR	MBCIG31D5ER	MBCIG31D5FR	
	Ground Chipbreaker Left Hand for Right Hand Bars  TPCG Style	DURA-MAX® 3000/4000 Carbide* For Steel & Interrupted Cutting	.002"	MBCIG02D3UL	MBCIG02D3CL	MBCIG02D3DL	MBCIG02D3EL	MBCIG02D3FL
			.007"	MBCIG07D3UL	MBCIG07D3CL	MBCIG07D3DL	MBCIG07D3EL	MBCIG07D3FL
			.015"	MBCIG15D4UL	MBCIG15D4CL	MBCIG15D4DL	MBCIG15D4EL	MBCIG15D4FL
			.031"	MBCIG31D3UL	MBCIG31D3CL	MBCIG31D3DL	MBCIG31D3EL	MBCIG31D3FL
DURA-MAX® 5000 Carbide For Aluminum & Nonferrous		.002"	MBCIG02D5UL	MBCIG02D5CL	MBCIG02D5DL	MBCIG02D5EL	MBCIG02D5FL	
		.007"	MBCIG07D5UL	MBCIG07D5CL	MBCIG07D5DL	MBCIG07D5EL	MBCIG07D5FL	
		.015"	MBCIG15D5UL	MBCIG15D5CL	MBCIG15D5DL	MBCIG15D5EL	MBCIG15D5FL	
		.031"	MBCIG31D5UL	MBCIG31D5CL	MBCIG31D5DL	MBCIG31D5EL	MBCIG31D5FL	

* For some details, **DURA-MAX® 4000** may be substituted.



KAISER TOOL COMPANY, INC.

Phone: 888-THINBIT (888-844-6248) or (260) 484-3620
www.thinbit.com • Orders: orders@thinbit.com • Quotes: quotes@thinbit.com

**MBC BARS
& INSERTS
BORING**

PRODUCT SELECTION GUIDE - THREADING & CHAMFERING

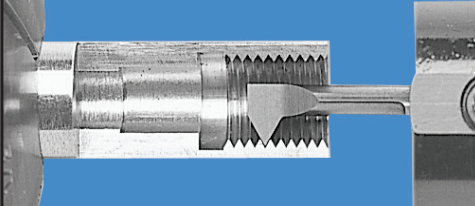
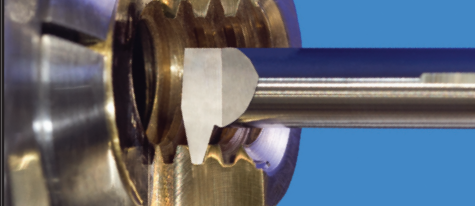
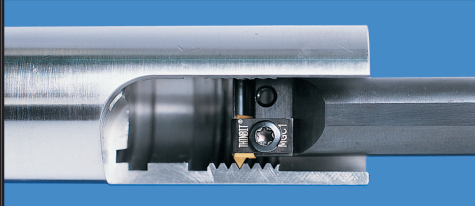
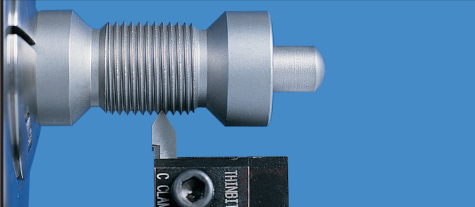
THREADING

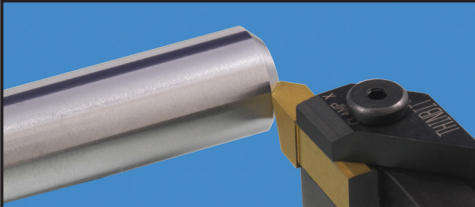
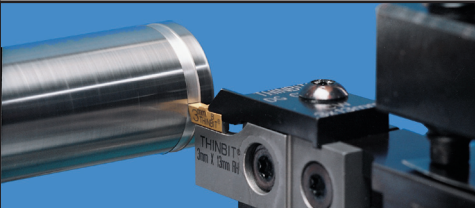
<p>PAGE 4-3</p>		<ul style="list-style-type: none"> • 60° Profile for internal diameters of .077" and larger • 4 Threads per inch and greater • Solid carbide shanks in 1/8", 3/16", 1/4", 5/16", 3/8" and 1/2" diameter
<p>PAGE 4-5</p>		<ul style="list-style-type: none"> • ACME profile • For internal diameters of .187" and larger • 6 Threads per inch and greater
<p>PAGE 4-7</p>		<ul style="list-style-type: none"> • 60° Profile for internal diameters of .325" and larger • 9 Threads per inch and greater
<p>PAGE 4-9</p>		<ul style="list-style-type: none"> • 60° Profile for external and internal threading • For internal diameters of 1.250" and larger • 8 Threads per inch and greater • Carbide and High Speed Steel
<p>PAGE 4-11</p>		<ul style="list-style-type: none"> • ACME Profile for external and internal threading • For internal diameters of 1.250" and larger • 4 Threads per inch and greater • Carbide and High Speed Steel
<p>PAGE 4-13</p>		<ul style="list-style-type: none"> • Chamfering inserts for external and internal use • For internal diameters of 1.250" and larger • Carbide and High Speed Steel
<p>PAGE 1-13</p>		<ul style="list-style-type: none"> • 3mm Threading & Chamfering style inserts (Pg. 6-2) • Can thread over a .500" long shoulder • Can back thread along a shoulder

THINBIT®

OVER 100,000 TOOLS IN STOCK FOR
GROOVING • THREADING • PARTING • BORING
TURNING • FACE GROOVING • MILLING

KAISER TOOL COMPANY, INC.

Phone: 888-THINBIT (888-844-6248) or (260) 484-3620
www.thinbit.com • Orders: orders@thinbit.com • Quotes: quotes@thinbit.com

TOOLING ORIENTATION GUIDE - THREADING & CHAMFERING

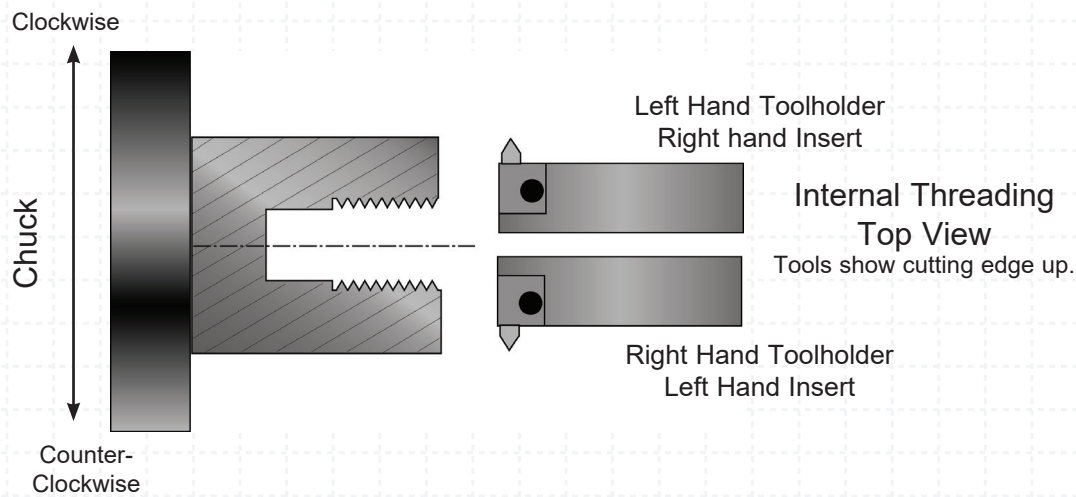
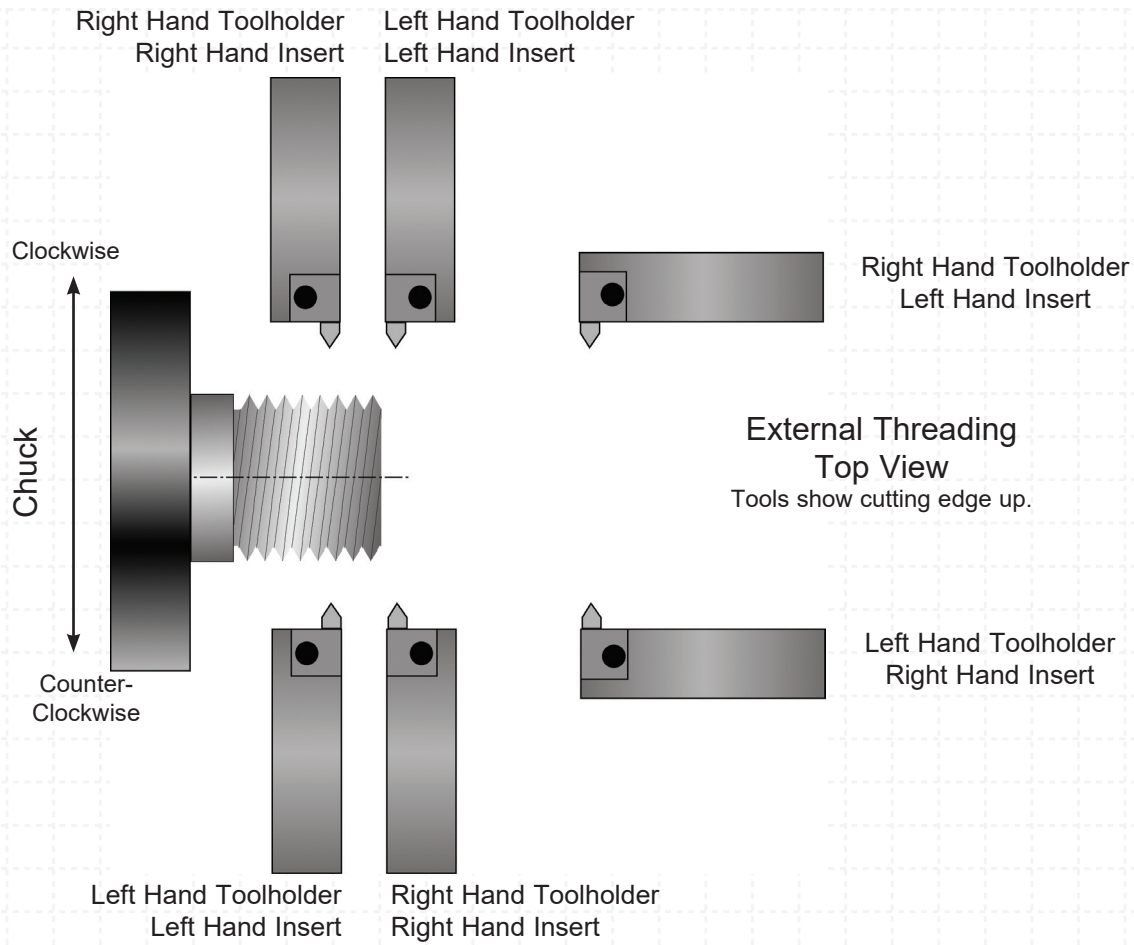

THREADING

KAISER TOOL COMPANY, INC.

Phone: 888-THINBIT (888-844-6248) or (260) 484-3620
www.thinbit.com • Orders: orders@thinbit.com • Quotes: quotes@thinbit.com

MICROBIT®

PRODUCT INFORMATION

- Internal threading for diameters .077" and larger.
- 4 threads per inch and greater.
- 1/8", 3/16", 1/4", 5/16", 3/8" and 1/2" shank.
- Short neck lengths for greater rigidity; long neck lengths for greater reach.
- Elliptically ground necks for greater strength; round necks to fit into small diameters.
- Sub-micron grain **DURA-MAX® 2000** Carbide.
- Tools can be coated with TiN, TiAlN, TiCN and Diamond coating.

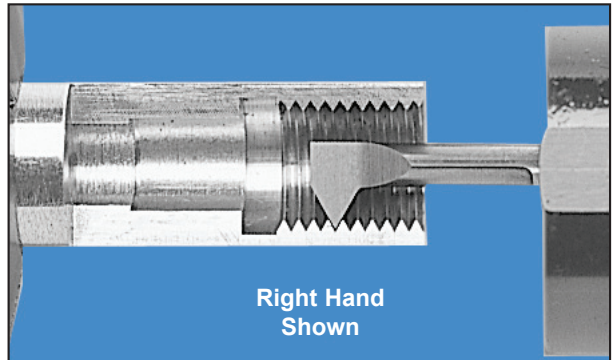

Right Hand Shown

MODIFICATIONS

SEE PAGE 8-3 FOR ADDITIONAL INFORMATION

INCLUDED ANGLE (TOP VIEW)

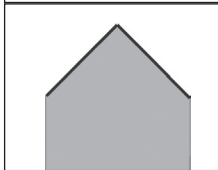

CUSTOM THREADS (TOP VIEW)

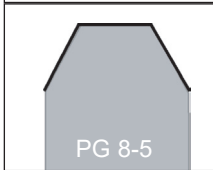

CUSTOM BLANK (TOP VIEW)

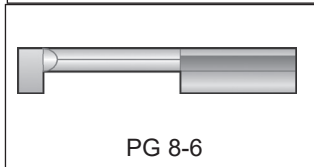

ADAPTER STYLES

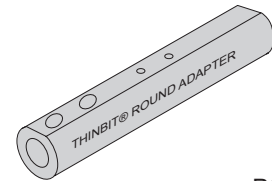

PG 7-2

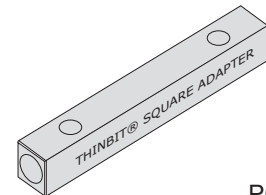

PG 7-2

TOOLHOLDER SELECTIONS

TECHNICAL SECTIONS

SPEEDS AND FEEDS

PG 9-18

APPLICATION REFERENCE

PG 9-4

TROUBLESHOOTING

PG 9-7

Right Hand Illustrated

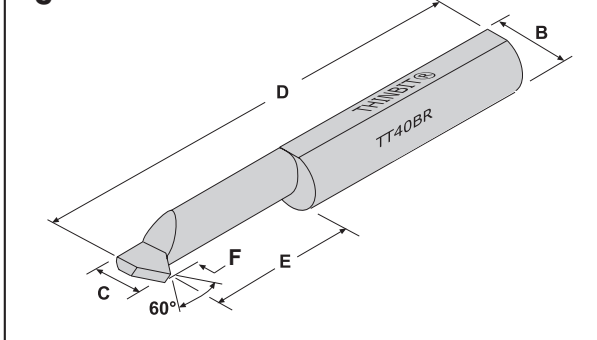

FRONT RAKE: Primary 21°

RADIUS: .002" or .000"

TOP RAKE: 0°

NOTE: Tool designed for feeding into bore only. Right hand tools should be used for right hand internal threads. Left hand tools should be used for left hand internal threads.

Select the **ORDER CODE** in the table on the next page that represents your selection of tool dimensions.

EXAMPLE:

The **ORDER CODE** for a .250" minimum bore, right hand tool for 5 to 56 T.P.I. and .596" tool reach is: **TT40BR**

KAISER TOOL COMPANY, INC.

Phone: 888-THINBIT (888-844-6248) or (260) 484-3620
www.thinbit.com • Orders: orders@thinbit.com • Quotes: quotes@thinbit.com

I.D. THREADING TOOLS

SPECIFICATIONS			ORDER CODE						INFORMATION			
Minimum Bore 'C'	Threads per Inch	Tool Reach	DURA-MAX® 2000 Carbide <small>See Page 9-18 for Speeds and Feeds Information</small>		Coatings <small>See Page 9-6 for Expanded Coating Descriptions</small>				Overall Length 'D'	Projection 'F'	Shank Diameter 'B'	Toolholder Page 7-2 Use Toolholders Beginning With
		Minimum 'E'	Right Hand	Left Hand	TiN	TiCN	TiAlN	Diamond				
.077" Round Neck	40 to 56	.291"	TT20AR	TT20AL	add 'C'	add 'D'	add 'E'	add 'F'	1.397"	.014"	1/8"	'AD'
		.416"	TT21AR	TT21AL								
	Over 56	.291"	TT20AR1	TT20AL1								
		.416"	TT21AR1	TT21AL1								
.125"	11 to 56	.312"	TT20BR	TT20BL	add 'C'	add 'D'	add 'E'	add 'F'	1.439"	.050"	1/8"	'AD'
		.437"	TT21BR	TT21BL								
	Over 56	.312"	TT20BR1	TT20BL1								
		.437"	TT21BR1	TT21BL1								
	27 to 56	.294"	TT20CR	TT20CL					1.404"	.020"		
		.419"	TT21CR	TT21CL								
	Over 56	.294"	TT20CR1	TT20CL1								
		.419"	TT21CR1	TT21CL1								
.187"	7 to 56	.454"	TT30BR	TT30BL	add 'C'	add 'D'	add 'E'	add 'F'	1.974"	.080"	3/16"	'AD'
		.704"	TT31BR	TT31BL								
	Over 56	.454"	TT30BR1	TT30BL1								
		.704"	TT31BR1	TT31BL1								
	16 to 56	.428"	TT30CR	TT30CL					1.922"	.035"		
		.678"	TT31CR	TT31CL								
	Over 56	.428"	TT30CR1	TT30CL1								
		.678"	TT31CR1	TT31CL1								
.250"	5 to 56	.596"	TT40BR	TT40BL	add 'C'	add 'D'	add 'E'	add 'F'	2.508"	.110"	1/4"	'AD'
		.846"	TT41BR	TT41BL								
	Over 56	.596"	TT40BR1	TT40BL1								
		.846"	TT41BR1	TT41BL1								
	11 to 56	.562"	TT40CR	TT40CL					2.439"	.050"		
		.812"	TT41CR	TT41CL								
	Over 56	.562"	TT40CR1	TT40CL1								
		.812"	TT41CR1	TT41CL1								
.313"	4 to 56	.739"	TT50BR	TT50BL	add 'C'	add 'D'	add 'E'	add 'F'	2.513"	.140"	5/16"	'AD'
		1.114"	TT51BR	TT51BL								
	Over 56	.739"	TT50BR1	TT50BL1								
		1.114"	TT51BR1	TT51BL1								
	9 to 56	.694"	TT50CR	TT50CL					2.424"	.063"		
		1.069"	TT51CR	TT51CL								
	Over 56	.694"	TT50CR1	TT50CL1								
		1.069"	TT51CR1	TT51CL1								
.375"	5 to 56	.846"	TT60CR	TT60CL	add 'C'	add 'D'	add 'E'	add 'F'	2.948"	.110"	3/8"	'AD'
		1.346"	TT61CR	TT61CL								
	Over 56	.846"	TT60CR1	TT60CL1								
		1.346"	TT61CR1	TT61CL1								
.500"	4 to 56	1.119"	TT80CR	TT80CL	add 'C'	add 'D'	add 'E'	add 'F'	3.434"	.150"	1/2"	'AD'
		1.869"	TT81CR	TT81CL								
	Over 56	1.119"	TT80CR1	TT80CL1								
		1.869"	TT81CR1	TT81CL1								

**I.D. TOOLS
THREADING**

MICROBIT®

PRODUCT INFORMATION

- Internal ACME threading for diameters .187" and larger.
- 6 threads per inch and greater.
- 3/16", 1/4", 5/16" and 3/8".
- Short neck lengths for greater rigidity; long neck lengths for greater reach.
- Elliptically ground necks for greater strength; round necks to fit into small diameters.
- Sub-micron grain **DURA-MAX® 2000** Carbide.
- Tools can be coated with TiN, TiAlN, TiCN and Diamond coating.

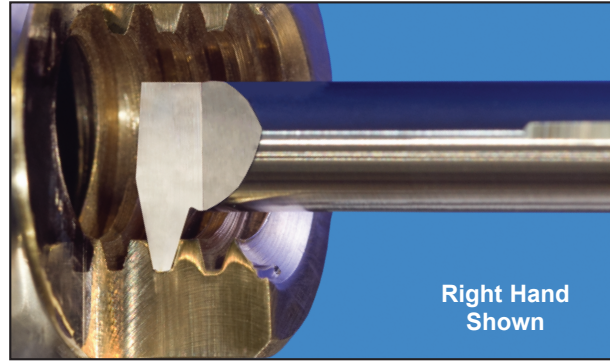

Right Hand Shown

MODIFICATIONS

SEE PAGE
8-3
FOR ADDITIONAL
INFORMATION

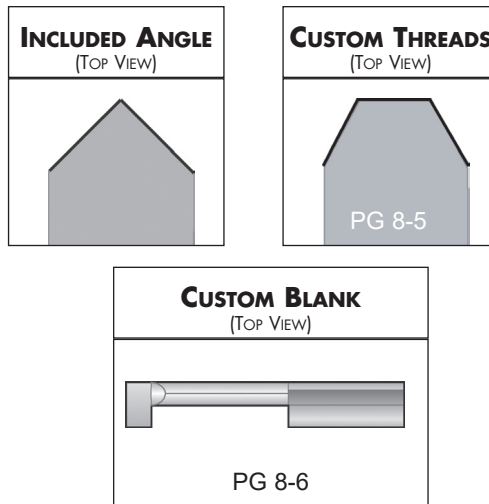

TOOLHOLDER SELECTIONS

ADAPTER STYLES

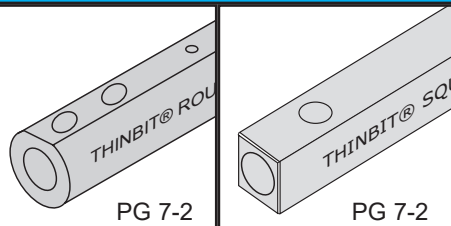

TECHNICAL SECTIONS

SPEEDS AND FEEDS

PG 9-18

APPLICATION REFERENCE

PG 9-4

TROUBLESHOOTING

PG 9-7

KAISER TOOL COMPANY, INC.

Phone: 888-THINBIT (888-844-6248) or (260) 484-3620
www.thinbit.com • Orders: orders@thinbit.com • Quotes: quotes@thinbit.com

I.D. ACME THREADING TOOLS

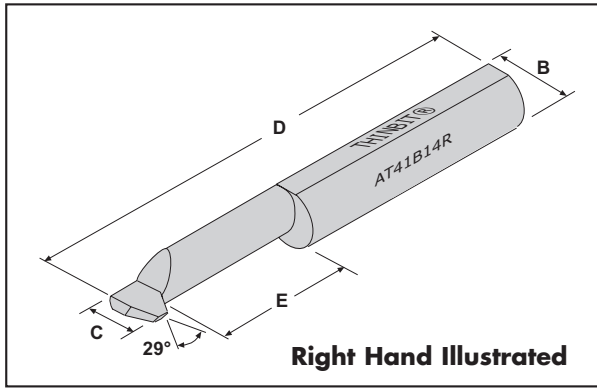

FRONT RAKE: Primary 21°

TOP RAKE: 0°

NOTE: Tool designed for feeding into bore only. Right hand tools should be used for right hand internal threads. Left hand tools should be used for left hand internal threads.

- 29° ACME threading tools for internal applications.
- ACME threading tools can be used to cut other thread profiles by over cutting.
- Single lead

ORDERING INSTRUCTIONS

Select the **ORDER CODE** in the table below that represents your selection of tool dimensions.

EXAMPLE:

The **ORDER CODE** for a .250" minimum bore, right hand tool for 14 or fewer T.P.I. and .750" tool reach is:

AT41B14R

SPECIFICATIONS				ORDER CODE						INFORMATION		
Minimum Bore 'C'	Threads per Inch	Flat at Tip	Tool Reach 'E' Minimum	DURA-MAX® 2000 Carbide See Page 9-18 for Speeds and Feeds information		Coatings See Page 9-6 for Expanded Coating Descriptions Use Uncoated Part Number and Add Coating Code				Overall Length 'D'	Shank Diameter 'B'	Toolholder Page 7-2 Use Toolholders Beginning With
				Right Hand	Left Hand	TiN	TiCN	TiAlN	Diamond			
.187"	16	.021"	.625"	AT31B16R	AT31B16L					1.902"	3/16"	'AD'
.250"	14	.024"	.750"	AT41B14R	AT41B14L					2.413"	1/4"	
.313"	12	.028"	1.000"	AT51B12R	AT51B12L	add 'C'	add 'D'	add 'E'	add 'F'	2.388"	5/16"	
.375"	10	.032"	1.250"	AT61C10R	AT61C10L					2.893"	3/8"	
.375"	6	.057"	1.250"	AT61C06R	AT61C06L					2.863"	3/8"	

I.D. ACME THREADING

KAISER TOOL COMPANY, INC.

Phone: 888-THINBIT (888-844-6248) or (260) 484-3620
 www.thinbit.com • Orders: orders@thinbit.com • Quotes: quotes@thinbit.com

PRODUCT INFORMATION

- Internal threading for diameters .325" and larger.
- 9 threads per inch and greater.
- Sub-micron grain **DURA-MAX[®] 2000** and **5000** Carbides.
- Inserts available coated with TiN, TiAlN, TiCN and Diamond coating.



MODIFICATIONS
SEE PAGE 8-3 FOR ADDITIONAL INFORMATION

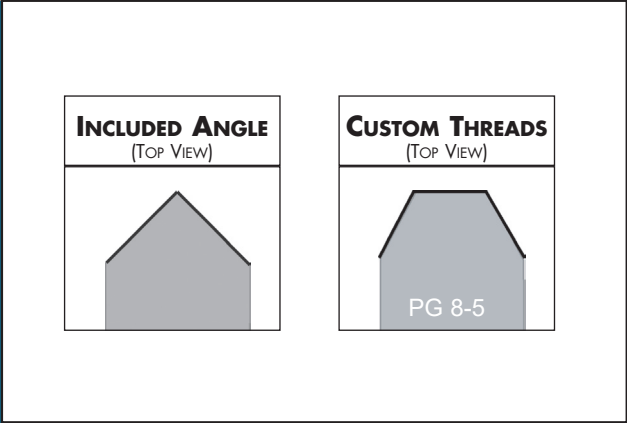

TOOLHOLDER SELECTION

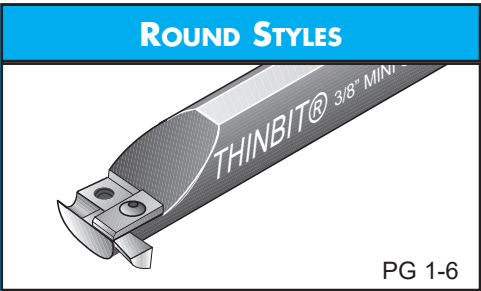

	SPEEDS AND FEEDS	APPLICATION REFERENCE	TROUBLESHOOTING
TECHNICAL SECTIONS	PG 9-18	PG 9-4	PG 9-7

KAISER TOOL COMPANY, INC.

Phone: 888-THINBIT (888-844-6248) or (260) 484-3620
www.thinbit.com • Orders: orders@thinbit.com • Quotes: quotes@thinbit.com

I.D. THREADING TOOLS

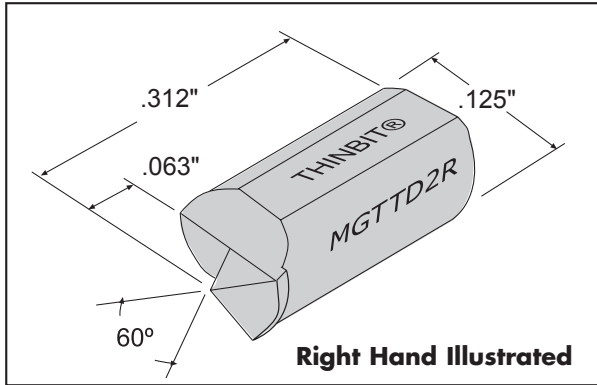

FRONT RAKE: 15°
 RADIUS: .002" or .000"
 TOP RAKE: 0°

ORDERING INSTRUCTIONS

Select the **ORDER CODE** in the table below that represents your selection of insert specifications.

EXAMPLE:
 The **ORDER CODE** for a right hand, 9 to 56 Threads Per Inch **DURA-MAX® 2000** Carbide insert with TiN coating is:
MGTTD2RC

**I.D. TOOLS
 THREADING**

SPECIFICATIONS		ORDER CODE						INFO.
Insert Orientation	Threads per Inch	Insert Grades <small>See Page 9-5 for Expanded Material Descriptions and Page 9-18 for Speeds and Feeds</small>		Coatings <small>See Page 9-6 for Expanded Coating Descriptions</small>				Toolholder Page 1-6 Use Toolholders Beginning With
		DURA-MAX® 2000 Carbide <small>For Steel & Interrupted Cutting</small>	DURA-MAX® 5000 Carbide <small>For Aluminum & Nonferrous</small>	Use Uncoated Part Number and Add Coating Code				
				TiN	TiCN	TiAlN	Diamond	
Right Hand	9 to 56	MGTTD2R	MGTTD5R	add 'C'	add 'D'	add 'E'	add 'F'	'MGT'
	Greater than 56	MGTTD2R1	MGTTD5R1					Use left hand holder
Left Hand	9 to 56	MGTTD2L	MGTTD5L	add 'C'	add 'D'	add 'E'	add 'F'	'MGT'
	Greater than 56	MGTTD2L1	MGTTD5L1					Use right hand holder

KAISER TOOL COMPANY, INC.

Phone: 888-THINBIT (888-844-6248) or (260) 484-3620
 www.thinbit.com • Orders: orders@thinbit.com • Quotes: quotes@thinbit.com

GROOVE 'N TURN[®] INSERTS

U.S. PATENT NOS. 6,688,816 and 6,824,333

PRODUCT INFORMATION	<ul style="list-style-type: none"> • External threading within .065" of a shoulder. • Internal threading with 1.250" minimum bore diameter. • 8 threads per inch and greater. • Sub-micron grain DURA-MAX[®] 2000 and 5000 Carbides and High Speed Steel. • Inserts can be coated with TiN, TiAlN, TiCN and Diamond coating.
----------------------------	--

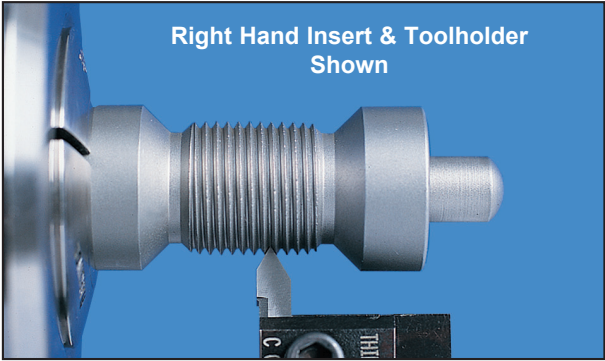

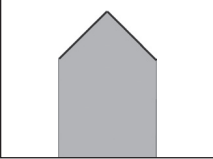
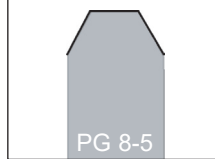
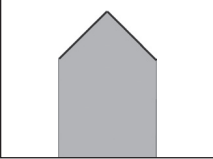
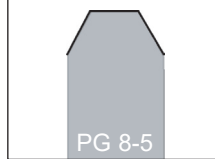
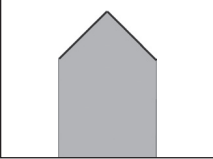
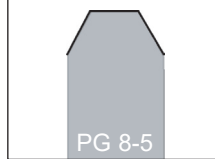
MODIFICATIONS SEE PAGE 8-3 FOR ADDITIONAL INFORMATION	<table border="1" style="width: 100%;"> <tr> <td style="text-align: center;"> INCLUDED ANGLE (Top View)  </td> <td style="text-align: center;"> CUSTOM THREADS (Top View)  </td> </tr> </table>	INCLUDED ANGLE (Top View) 	CUSTOM THREADS (Top View) 
INCLUDED ANGLE (Top View) 	CUSTOM THREADS (Top View) 		

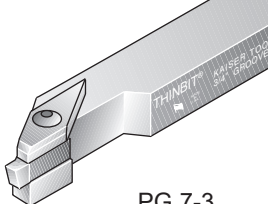
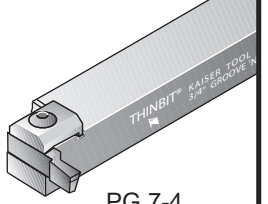
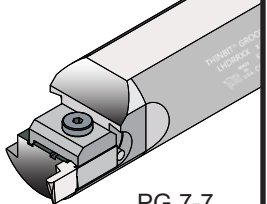
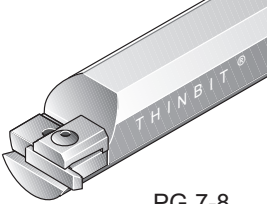
TOOLHOLDER SELECTIONS	CNC, SWISS, CONVENTIONAL STYLE		ROUND STYLE	
	 PG 7-3	 PG 7-4	 PG 7-7	 PG 7-8

TECHNICAL SECTIONS	SPEEDS AND FEEDS	APPLICATION REFERENCE	TROUBLESHOOTING
	PG 9-18	PGS 9-3 & 9-4	PG 9-7

KAISER TOOL COMPANY, INC.

Phone: 888-THINBIT (888-844-6248) or (260) 484-3620
 www.thinbit.com • Orders: orders@thinbit.com • Quotes: quotes@thinbit.com

THREADING INSERTS

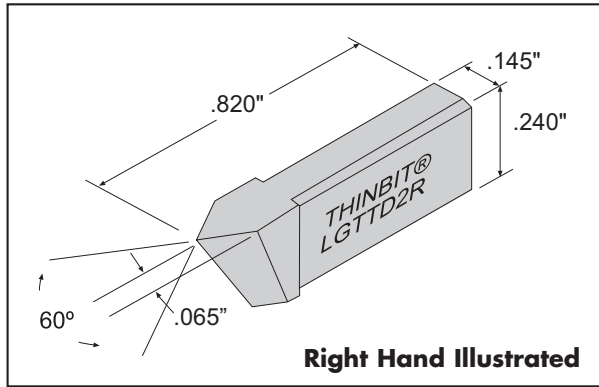

FRONT RAKE: 15°
 RADIUS: .002" or .000"
 TOP RAKE: 0°

ORDERING INSTRUCTIONS

Select the **ORDER CODE** in the table below that represents your selection of orientation and insert grade.

EXAMPLE:

The **ORDER CODE** for a right hand, 8 to 56 Threads Per Inch threading insert in **DURA-MAX® 2000** is:
LGTTD2R

**INSERTS
THREADING**

SPECIFICATIONS		ORDER CODE						INFO.	
Insert Orientation	Threads per Inch	Insert Grades <small>See Page 9-5 for expanded material selections and Page 9-18 for Speeds and Feeds information</small>			Coatings <small>See Page 9-6 for Expanded Coating Descriptions</small>				Toolholder Catalog Section 7 Use Toolholders Beginning With
		DURA-MAX® 2000 Carbide <small>For Steel & Interrupted Cutting</small>	DURA-MAX® 5000 Carbide <small>For Aluminum & Nonferrous</small>	High Speed Steel	Use Uncoated Part Number and Add Coating Code				
					TiN	TiCN	TiAlN	Diamond	
Right Hand <small>For right hand external threads or left hand internal threads</small>	8 to 56	LGTTD2R	LGTTD5R	LGTTHSR	add 'C'	add 'D'	add 'E'	add 'F'	'L' Use right hand straight holder or left hand 90° holder
	Greater than 56	LGTTD2R1	LGTTD5R1	LGTTHSR1					
Left Hand <small>For left hand external threads or right hand internal threads</small>	8 to 56	LGTTD2L	LGTTD5L	LGTTHSL	add 'C'	add 'D'	add 'E'	add 'F'	'L' Use left hand straight holder or right hand 90° holder
	Greater than 56	LGTTD2L1	LGTTD5L1	LGTTHSL1					

KAISER TOOL COMPANY, INC.

Phone: 888-THINBIT (888-844-6248) or (260) 484-3620
 www.thinbit.com • Orders: orders@thinbit.com • Quotes: quotes@thinbit.com

GROOVE 'N TURN® INSERTS

U.S. PATENT NOS. 6,688,816 and 6,824,333

PRODUCT INFORMATION	<ul style="list-style-type: none"> • External threading within .070" of a shoulder. • Internal ACME threading with 1.250" minimum bore diameter. • 4 threads per inch and greater. • Sub-micron grain DURA-MAX® 2000 and 5000 Carbides and High Speed Steel. • Inserts can be coated with TiN, TiAlN, TiCN and Diamond coating.
----------------------------	--

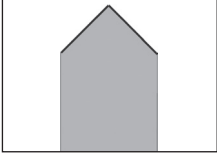
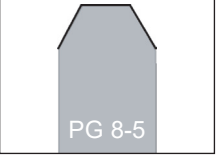
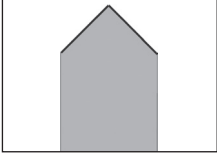
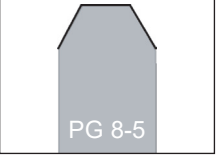
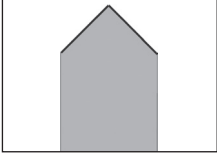
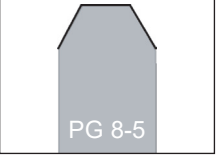

MODIFICATIONS SEE PAGE 8-3 FOR ADDITIONAL INFORMATION	<table border="1" style="width: 100%;"> <tr> <td style="width: 50%; text-align: center;"> INCLUDED ANGLE (TOP VIEW) </td> <td style="width: 50%; text-align: center;"> CUSTOM THREADS (TOP VIEW) </td> </tr> </table>	INCLUDED ANGLE (TOP VIEW) 	CUSTOM THREADS (TOP VIEW) 
INCLUDED ANGLE (TOP VIEW) 	CUSTOM THREADS (TOP VIEW) 		

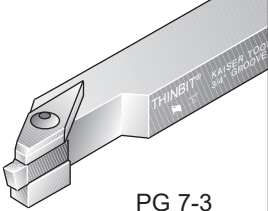
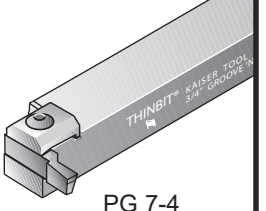
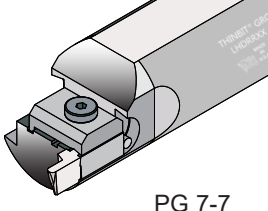
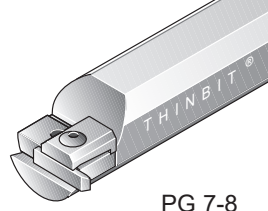
	CNC, SWISS, CONVENTIONAL STYLE	ROUND STYLE		
TOOLHOLDER SELECTIONS	 PG 7-3	 PG 7-4	 PG 7-7	 PG 7-8

	SPEEDS AND FEEDS	APPLICATION REFERENCE	TROUBLESHOOTING
TECHNICAL SECTIONS	PG 9-18	PGS 9-3 & 9-4	PG 9-7

KAISER TOOL COMPANY, INC.

Phone: 888-THINBIT (888-844-6248) or (260) 484-3620
www.thinbit.com • Orders: orders@thinbit.com • Quotes: quotes@thinbit.com

ACME THREADING INSERTS

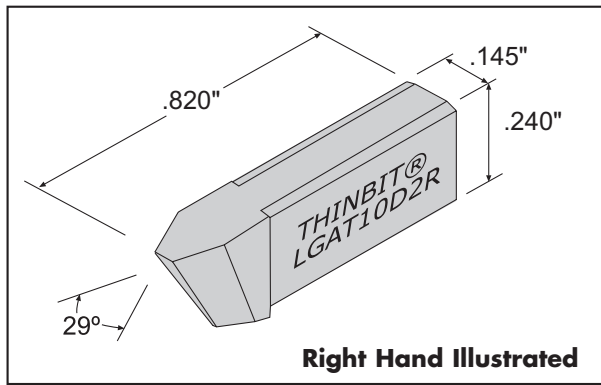

FRONT RAKE: 15°

TOP RAKE: 0°

- 29° ACME threading inserts for internal and external applications.
- ACME threading tools can be used to cut other thread profiles by over cutting.
- Single lead

ORDERING INSTRUCTIONS

Select the **ORDER CODE** in the table below that represents your selection of orientation and insert grade.

EXAMPLE:

The **ORDER CODE** for a right hand ACME threading insert in **DURA-MAX® 2000** with 10 or fewer T.P.I. is:
LGAT10D2R

**ACME INSERTS
THREADING**

SPECIFICATIONS			ORDER CODE				INFO.			
Insert Orientation	Threads per Inch	Flat at Tip	Insert Grades See Page 9-5 for expanded material selections and Page 9-18 for Speeds and Feeds information			Coatings See page 9-6 for expanded coating descriptions Use Uncoated Part Number and Add Coating Code				Toolholder Catalog Section 7 Use Toolholders Beginning With
			DURA-MAX® 2000 Carbide For Steel & Interrupted Cutting	DURA-MAX® 5000 Carbide For Aluminum & Nonferrous	High Speed Steel	TiN	TiCN	TiAlN	Diamond	
Centered right hand, left hand, internal and external threads	4	.087"	LGAT04D2R	LGAT04D5R	LGAT04HSR	add 'C'	add 'D'	add 'E'	add 'F'	'L'
	5	.069"	LGAT05D2R	LGAT05D5R	LGAT05HSR					
	6	.057"	LGAT06D2R	LGAT06D5R	LGAT06HSR					
	8	.041"	LGAT08D2R	LGAT08D5R	LGAT08HSR					
	10	.032"	LGAT10D2R	LGAT10D5R	LGAT10HSR					
	12	.028"	LGAT12D2R	LGAT12D5R	LGAT12HSR					
	14	.024"	LGAT14D2R	LGAT14D5R	LGAT14HSR					
	16	.021"	LGAT16D2R	LGAT16D5R	LGAT16HSR					
										or Use left hand straight holder, or right hand 90° holder, for left hand external threads or right hand internal threads

KAISER TOOL COMPANY, INC.

Phone: 888-THINBIT (888-844-6248) or (260) 484-3620
www.thinbit.com • Orders: orders@thinbit.com • Quotes: quotes@thinbit.com

GROOVE 'N TURN[®] INSERTS

U.S. PATENT NOS. 6,688,816 and 6,824,333

PRODUCT INFORMATION	<ul style="list-style-type: none"> • Chamfering within .090" of a shoulder. • Internal chamfering with 1.250" minimum bore diameter. • Sub-micron grain DURA-MAX[®] 2000 and 5000 Carbides and High Speed Steel. • Inserts can be coated with TiN, TiAlN, TiCN and Diamond coating.
----------------------------	--



MODIFICATIONS SEE PAGE 8-3 FOR ADDITIONAL INFORMATION	<table border="1" style="width: 100%;"> <tr> <td style="text-align: center;"> INCLUDED ANGLE (TOP VIEW) </td> <td style="text-align: center;"> CUSTOM THREADS (TOP VIEW) PG 8-5 </td> </tr> </table>	INCLUDED ANGLE (TOP VIEW) 	CUSTOM THREADS (TOP VIEW) PG 8-5
INCLUDED ANGLE (TOP VIEW) 	CUSTOM THREADS (TOP VIEW) PG 8-5		

TOOLHOLDER SELECTIONS	CNC, SWISS, CONVENTIONAL STYLE		ROUND STYLE	
	 PG 7-3	 PG 7-4	 PG 7-7	 PG 7-8

TECHNICAL SECTIONS	SPEEDS AND FEEDS	APPLICATION REFERENCE	TROUBLESHOOTING
	PG 9-18	PGS 9-3 & 9-4	PG 9-7

KAISER TOOL COMPANY, INC.

Phone: 888-THINBIT (888-844-6248) or (260) 484-3620
 www.thinbit.com • Orders: orders@thinbit.com • Quotes: quotes@thinbit.com

CHAMFERING INSERTS

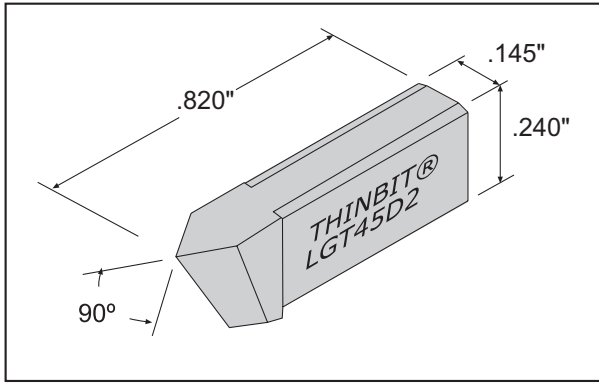

FRONT RAKE: 15°
 MAXIMUM RADIUS: .002"
 TOP RAKE: 0°

ORDERING INSTRUCTIONS

Select the **ORDER CODE** in the table below that represents your selection of orientation and insert grade.

EXAMPLE:

The **ORDER CODE** for a chamfering insert in **DURA-MAX® 2000** is:

LGT45D2

**CHAMFERING INSERTS
 THREADING**

SPECIFICATIONS		ORDER CODE							INFO.
Insert Orientation	Flat at Tip	Insert Grades <small>See Page 9-5 for expanded material selections and Page 9-18 for speeds and feeds information</small>			Coatings <small>See Page 9-6 for expanded coating descriptions</small>				Toolholder Catalog Section 7 Use Toolholders Beginning With
		DURA-MAX® 2000 Carbide <small>For Steel & Interrupted Cutting</small>	DURA-MAX® 5000 Carbide <small>For Aluminum & Nonferrous</small>	High Speed Steel	Use Uncoated Part Number and Add Coating Code				
					TiN	TiCN	TiAlN	Diamond	
Centered	None	LGT45D2	LGT45D5	LGT45HS	add 'C'	add 'D'	add 'E'	add 'F'	'L'

KAISER TOOL COMPANY, INC.

Phone: 888-THINBIT (888-844-6248) or (260) 484-3620
 www.thinbit.com • Orders: orders@thinbit.com • Quotes: quotes@thinbit.com

PRODUCT SELECTION GUIDE - PARTING

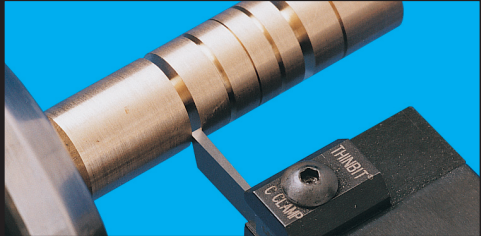
PAGE 5-3		<ul style="list-style-type: none">• For diameters 1" and smaller• Parting widths .025", .045", .062", .085" & .115"• Typically used for Conventional and Swiss machining, precious metals and small diameter parts
-------------	---	--

PAGE 1-13		<ul style="list-style-type: none">• For diameters 2" and smaller• Parting widths 2, 3, 4, 5 and 6mm• Typically used for CNC machining and large diameter parts
--------------	---	--

PARTING

THINBIT®

OVER 100,000 TOOLS IN STOCK FOR
GROOVING • THREADING • PARTING
BORING • TURNING • FACE GROOVING
SPECIALS • FORM TOOLS • MILLING

KAISER TOOL COMPANY, INC.

Phone: 888-THINBIT (888-844-6248) or (260) 484-3620
www.thinbit.com • Orders: orders@thinbit.com • Quotes: quotes@thinbit.com

TOOLING ORIENTATION GUIDE - PARTING

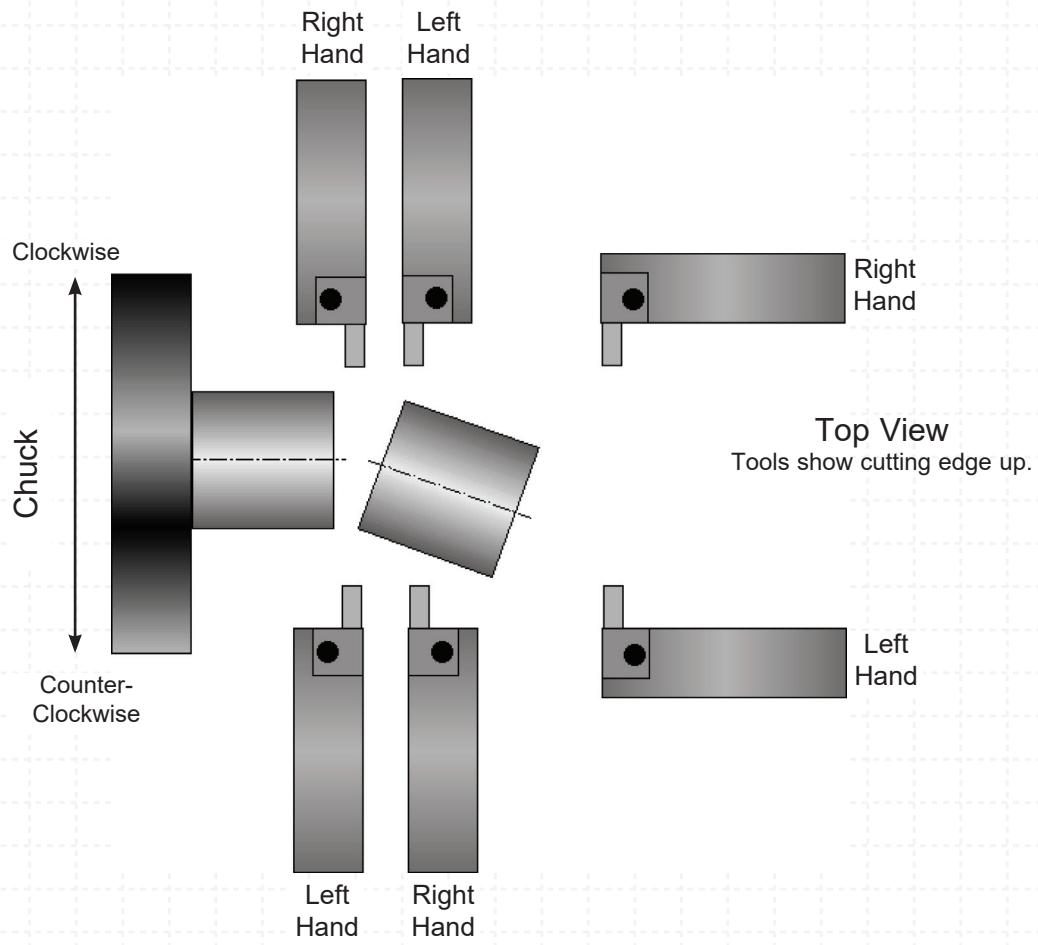

PARTING

KAISER TOOL COMPANY, INC.

Phone: 888-THINBIT (888-844-6248) or (260) 484-3620
www.thinbit.com • Orders: orders@thinbit.com • Quotes: quotes@thinbit.com

GROOVE 'N TURN® PARTING INSERTS

U.S. PATENT NOS. 6,688,816 and 6,824,333

PRODUCT INFORMATION

- .025", .045", .062", .085" and .115"
- Parting off up to 1" diameter
- 0° or 7° lead angle
- Centered or Offset
- Sub-micron grain **DURA-MAX® 2000** and **5000** Carbides and High Speed Steel.
- Inserts available with TiN, TiAlN, TiCN and Diamond coating.

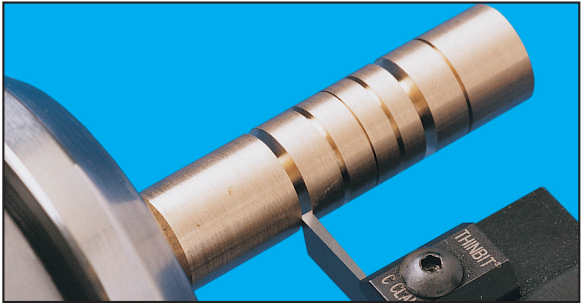

MODIFICATIONS

SEE PAGE 8-3 FOR ADDITIONAL INFORMATION

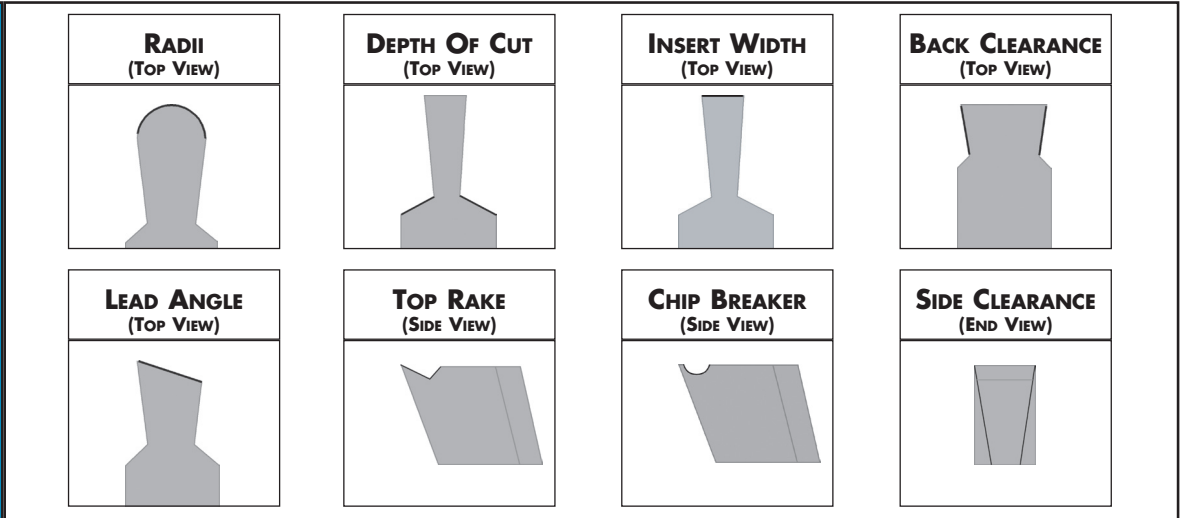

TOOLHOLDER SELECTIONS

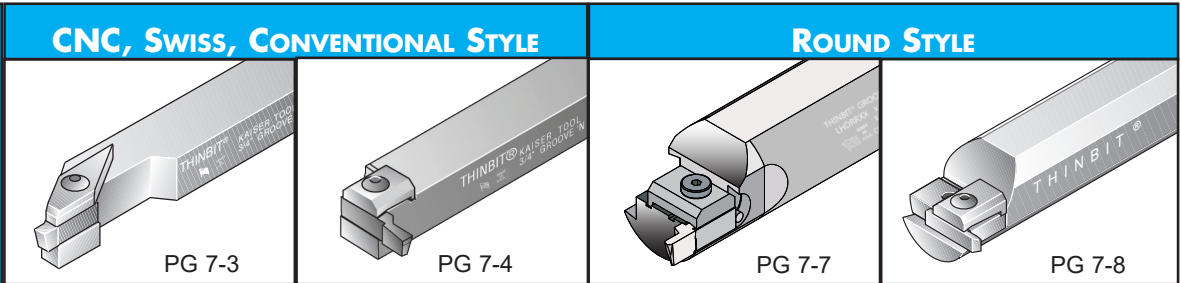

TECHNICAL SECTIONS

SPEEDS AND FEEDS	APPLICATION REFERENCE	TROUBLESHOOTING
PG 9-20	PGS 9-3 & 9-4	PG 9-7

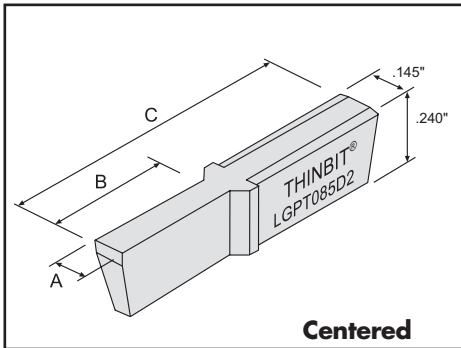

- FRONT RAKE:
 CARBIDE: Primary 7° honed, Secondary 15°
 HIGH SPEED STEEL: 15°
- BACK CLEARANCE:
 0° LGPT045HS & LGPT062HS
 1° all others
- SIDE CLEARANCE: 1°
- RADIUS: None
- TOP RAKE: 0°
- LEAD ANGLE: 0° or 7°

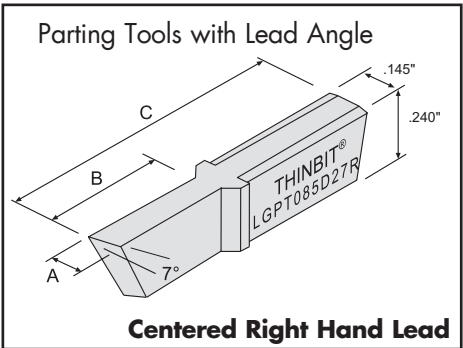

KAISER TOOL COMPANY, INC.

Phone: 888-THINBIT (888-844-6248) or (260) 484-3620
 www.thinbit.com • Orders: orders@thinbit.com • Quotes: quotes@thinbit.com















PARTING INSERTS

ORDERING INSTRUCTIONS

Select the **ORDER CODE** in the table below that represents your selection of groove width and insert grade.

EXAMPLE:

The **ORDER CODE** for an .085" wide parting insert in **DURA-MAX® 2000** is:
LGPT085D2

SPECIFICATIONS				ORDER CODE						INFORMATION												
Insert Width 'A' ±.001"	Insert Orientation	Lead Angle Orientation Right Hand Left Hand	Depth of Cut 'B'	Insert Grades See Page 9-5 for expanded material descriptions and Page 9-20 for Speeds and Feeds information			Coatings See Page 9-6 for expanded coating descriptions				Overall Length 'C'	Toolholder Catalog Section 7 Use Toolholders Beginning With										
				DURA-MAX® 2000 Carbide For Steel & Interrupted Cutting	DURA-MAX® 5000 Carbide For Aluminum & Non-ferrous	High Speed Steel	TIN	TiCN	TiAlN	Diamond												
.025"	Centered 	0°	.200"	LGPT025D2	LGPT025D5	LGPT025HS					.820" Carbide .825" HSS											
		7° Right Hand		LGPT025D27R	LGPT025D57R	LGPT025HS7R																
		7° Left Hand		LGPT025D27L	LGPT025D57L	LGPT025HS7L																
	Right Hand 	0°		LGPT025D2R	LGPT025D5R	LGPT025HSR																
		7° Right Hand		LGPT025D2R7R	LGPT025D5R7R	LGPT025HSR7R																
		7° Left Hand		LGPT025D2R7L	LGPT025D5R7L	LGPT025HSR7L																
	Left Hand 	0°		LGPT025D2L	LGPT025D5L	LGPT025HSL																
		7° Right Hand		LGPT025D2L7R	LGPT025D5L7R	LGPT025HSL7R																
		7° Left Hand		LGPT025D2L7L	LGPT025D5L7L	LGPT025HSL7L																
	.045"	Centered 		0°	.500"	LGPT045D2							LGPT045D5	LGPT045HS					'L' Series Centered Use any straight holder or 90° holder			
				7° Right Hand		LGPT045D27R							LGPT045D57R	LGPT045HS7R								
				7° Left Hand		LGPT045D27L							LGPT045D57L	LGPT045HS7L								
Right Hand 		0°	LGPT045D2R	LGPT045D5R		LGPT045HSR																
		7° Right Hand	LGPT045D2R7R	LGPT045D5R7R		LGPT045HSR7R																
		7° Left Hand	LGPT045D2R7L	LGPT045D5R7L		LGPT045HSR7L																
Left Hand 		0°	LGPT045D2L	LGPT045D5L		LGPT045HSL																
		7° Right Hand	LGPT045D2L7R	LGPT045D5L7R		LGPT045HSL7R																
		7° Left Hand	LGPT045D2L7L	LGPT045D5L7L		LGPT045HSL7L																
.062"		Centered 	0°	.500"		LGPT062D2	LGPT062D5	LGPT062HS	add 'C'	add 'D'	add 'E'	add 'F'	1.062" Carbide	Right Hand Use right hand straight holder or left hand 90° holder								
			7° Right Hand			LGPT062D27R	LGPT062D57R	LGPT062HS7R														
			7° Left Hand			LGPT062D27L	LGPT062D57L	LGPT062HS7L														
	Right Hand 	0°	LGPT062D2R		LGPT062D5R	LGPT062HSR																
		7° Right Hand	LGPT062D2R7R		LGPT062D5R7R	LGPT062HSR7R																
		7° Left Hand	LGPT062D2R7L		LGPT062D5R7L	LGPT062HSR7L																
	Left Hand 	0°	LGPT062D2L		LGPT062D5L	LGPT062HSL																
		7° Right Hand	LGPT062D2L7R		LGPT062D5L7R	LGPT062HSL7R																
		7° Left Hand	LGPT062D2L7L		LGPT062D5L7L	LGPT062HSL7L																
	.085"	Centered 	0°		.500"	LGPT085D2	LGPT085D5	LGPT085HS											1.078" HSS	Left Hand Use left hand straight holder or right hand 90° holder		
			7° Right Hand			LGPT085D27R	LGPT085D57R	LGPT085HS7R														
			7° Left Hand			LGPT085D27L	LGPT085D57L	LGPT085HS7L														
Right Hand 		0°	LGPT085D2R	LGPT085D5R		LGPT085HSR																
		7° Right Hand	LGPT085D2R7R	LGPT085D5R7R		LGPT085HSR7R																
		7° Left Hand	LGPT085D2R7L	LGPT085D5R7L		LGPT085HSR7L																
Left Hand 		0°	LGPT085D2L	LGPT085D5L		LGPT085HSL																
		7° Right Hand	LGPT085D2L7R	LGPT085D5L7R		LGPT085HSL7R																
		7° Left Hand	LGPT085D2L7L	LGPT085D5L7L		LGPT085HSL7L																
.115"		Centered 	0°	.500"		LGPT115D2	LGPT115D5	LGPT115HS														
			7° Right Hand			LGPT115D27R	LGPT115D57R	LGPT115HS7R														
			7° Left Hand			LGPT115D27L	LGPT115D57L	LGPT115HS7L														
	Right Hand 	0°	LGPT115D2R		LGPT115D5R	LGPT115HSR																
		7° Right Hand	LGPT115D2R7R		LGPT115D5R7R	LGPT115HSR7R																
		7° Left Hand	LGPT115D2R7L		LGPT115D5R7L	LGPT115HSR7L																
	Left Hand 	0°	LGPT115D2L		LGPT115D5L	LGPT115HSL																
		7° Right Hand	LGPT115D2L7R		LGPT115D5L7R	LGPT115HSL7R																
		7° Left Hand	LGPT115D2L7L		LGPT115D5L7L	LGPT115HSL7L																

INSERTS PARTING

DEEPGROOVE®

U.S. PATENT NO. 5,638,728

PRODUCT INFORMATION

- 2, 3, 4, 5 and 6mm insert widths.
- Recessed pocket and raised edge for chip control.
- Internal grooving, external grooving, face grooving and parting.
- Sub-micron grain **DURA-MAX® 2000** carbide.
- Inserts available with TiN, TiAlN, TiCN and Diamond coating.

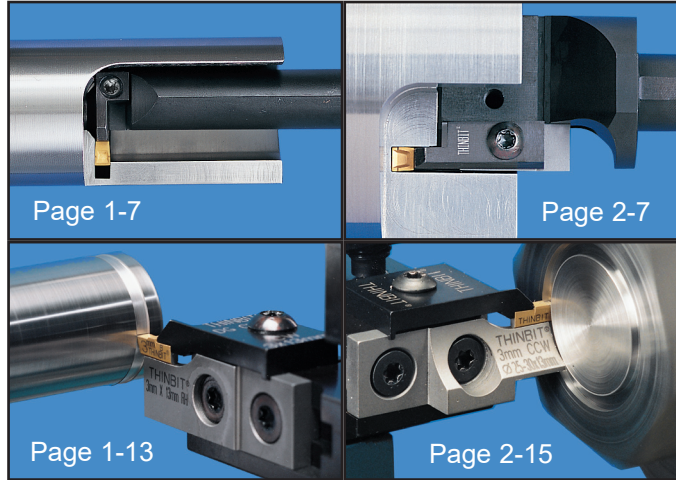

INSERT GEOMETRY

SHARP CORNER (TOP VIEW)	CORNER RADIUS (TOP VIEW)	FULL RADIUS (TOP VIEW)	60° THREADING (TOP VIEW)
7° LEAD ANGLE (TOP VIEW)	15°(+) TOP RAKE (SIDE VIEW)	15° (-) TOP RAKE (SIDE VIEW)	90° CHAMFERING (TOP VIEW)
Right Hand Left Hand			

TECHNICAL SECTIONS

SPEEDS AND FEEDS	APPLICATION REFERENCE	TROUBLESHOOTING
PGS 9-10, 9-12, 9-18 & 9-20	PGS 9-3 & 9-4	PG 9-7

ORDERING INSTRUCTIONS

Select the **ORDER CODE** in the table at right that represents your selection of insert geometry and coating. Please pay special attention to the '**Compatibility**' column to match the insert with the correct tooling.

The **ORDER CODE** for a 3mm wide, '**DGI**' Style insert with .015" radius and TiN coating is '**DGI30BC**'

KAISER TOOL COMPANY, INC.

Phone: 888-THINBIT (888-844-6248) or (260) 484-3620
 www.thinbit.com • Orders: orders@thinbit.com • Quotes: quotes@thinbit.com

'DGI' & 'DGM' STYLE OD/ID AND FACE GROOVING INSERTS

SPECIFICATIONS			ORDER CODE						
Insert Width +.005"/ -.000"	Compatibility	Insert Geometry	DURA-MAX® 2000 Carbide See Page 9-10 or 9-12 for Speeds and Feeds						
			Uncoated	TiN	TiCN Non-stock	TiAlN	Diamond Non-stock		
.078" (2mm)	Use in all 2mm 'DGP'	Sharp Corner	DGI20BU1	DGI20BC1	DGI20BD1	DGI20BE1	DGI20BF1		
		.004" (.10mm) radius	DGI20BU2010	DGI20BC2010	DGI20BD2010	DGI20BE2010	DGI20BF2010		
		.008" (.20mm) radius	DGI20BU2020	DGI20BC2020	DGI20BD2020	DGI20BE2020	DGI20BF2020		
		.010" (.25mm) radius	DGI20BU2025	DGI20BC2025	DGI20BD2025	DGI20BE2025	DGI20BF2025		
		.015" (.38mm) radius	DGI20BU	DGI20BC	DGI20BD	DGI20BE	DGI20BF		
		.020" (.50mm) radius	DGI20BU2050	DGI20BC2050	DGI20BD2050	DGI20BE2050	DGI20BF2050		
		.030" (.75mm) radius	DGI20BU2075	DGI20BC2075	DGI20BD2075	DGI20BE2075	DGI20BF2075		
		Full Radius	DGI20BU4	DGI20BC4	DGI20BD4	DGI20BE4	DGI20BF4		
		15° (+) Top Rake	DGI20BU7P	DGI20BC7P	DGI20BD7P	DGI20BE7P	DGI20BF7P		
		15° (-) Top Rake	DGI20BU7N	DGI20BC7N	DGI20BD7N	DGI20BE7N	DGI20BF7N		
		7° R.H. Lead Angle	DGI20BU3R	DGI20BC3R	DGI20BD3R	DGI20BE3R	DGI20BF3R		
		7° L.H. Lead Angle	DGI20BU3L	DGI20BC3L	DGI20BD3L	DGI20BE3L	DGI20BF3L		
		.118" (3mm)	Use ONLY with 3mm 'DGPZ' ID tools and face grooving heads with major diameter codes '02' and '25'	Sharp Corner	DGMI30BU1	DGMI30BC1	DGMI30BD1	DGMI30BE1	DGMI30BF1
.015" (.38mm) radius	DGMI30BU			DGMI30BC	DGMI30BD	DGMI30BE	DGMI30BF		
Use in 3mm 'DGP' for OD grooving/parting and major diameters greater than .984"	Sharp Corner		DGI30BU1	DGI30BC1	DGI30BD1	DGI30BE1	DGI30BF1		
	.004" (.10mm) radius		DGI30BU2010	DGI30BC2010	DGI30BD2010	DGI30BE2010	DGI30BF2010		
	.008" (.20mm) radius		DGI30BU2020	DGI30BC2020	DGI30BD2020	DGI30BE2020	DGI30BF2020		
	.010" (.25mm) radius		DGI30BU2025	DGI30BC2025	DGI30BD2025	DGI30BE2025	DGI30BF2025		
	.015" (.38mm) radius		DGI30BU	DGI30BC	DGI30BD	DGI30BE	DGI30BF		
	.020" (.50mm) radius		DGI30BU2050	DGI30BC2050	DGI30BD2050	DGI30BE2050	DGI30BF2050		
	.030" (.75mm) radius		DGI30BU2075	DGI30BC2075	DGI30BD2075	DGI30BE2075	DGI30BF2075		
	.040" (1.0mm) radius		DGI30BU2100	DGI30BC2100	DGI30BD2100	DGI30BE2100	DGI30BF2100		
	Full Radius		DGI30BU4	DGI30BC4	DGI30BD4	DGI30BE4	DGI30BF4		
	15° (+) Top Rake		DGI30BU7P	DGI30BC7P	DGI30BD7P	DGI30BE7P	DGI30BF7P		
	15° (-) Top Rake		DGI30BU7N	DGI30BC7N	DGI30BD7N	DGI30BE7N	DGI30BF7N		
	7° R.H. Lead Angle		DGI30BU3R	DGI30BC3R	DGI30BD3R	DGI30BE3R	DGI30BF3R		
	7° L.H. Lead Angle		DGI30BU3L	DGI30BC3L	DGI30BD3L	DGI30BE3L	DGI30BF3L		
	60° Threading		DGI30BU5	DGI30BC5	DGI30BD5	DGI30BE5	DGI30BF5		
	90° Chamfering		DGI30BU6	DGI30BC6	DGI30BD6	DGI30BE6	DGI30BF6		
	.157" (4mm)		Use ONLY with 4mm 'DGPZ' ID tools and face grooving heads with major diameter codes '02' and '25'	Sharp Corner	DGMI40BU1	DGMI40BC1	DGMI40BD1	DGMI40BE1	DGMI40BF1
				.015" (.38mm) radius	DGMI40BU	DGMI40BC	DGMI40BD	DGMI40BE	DGMI40BF
Use in 4mm 'DGP' for OD grooving/parting and major diameters greater than .984"		Sharp Corner	DGI40BU1	DGI40BC1	DGI40BD1	DGI40BE1	DGI40BF1		
		.004" (.10mm) radius	DGI40BU2010	DGI40BC2010	DGI40BD2010	DGI40BE2010	DGI40BF2010		
		.008" (.20mm) radius	DGI40BU2020	DGI40BC2020	DGI40BD2020	DGI40BE2020	DGI40BF2020		
		.010" (.25mm) radius	DGI40BU2025	DGI40BC2025	DGI40BD2025	DGI40BE2025	DGI40BF2025		
		.015" (.38mm) radius	DGI40BU	DGI40BC	DGI40BD	DGI40BE	DGI40BF		
		.020" (.50mm) radius	DGI40BU2050	DGI40BC2050	DGI40BD2050	DGI40BE2050	DGI40BF2050		
		.030" (.75mm) radius	DGI40BU2075	DGI40BC2075	DGI40BD2075	DGI40BE2075	DGI40BF2075		
		.040" (1.0mm) radius	DGI40BU2100	DGI40BC2100	DGI40BD2100	DGI40BE2100	DGI40BF2100		
		Full Radius	DGI40BU4	DGI40BC4	DGI40BD4	DGI40BE4	DGI40BF4		
		15° (+) Top Rake	DGI40BU7P	DGI40BC7P	DGI40BD7P	DGI40BE7P	DGI40BF7P		
		15° (-) Top Rake	DGI40BU7N	DGI40BC7N	DGI40BD7N	DGI40BE7N	DGI40BF7N		
		7° R.H. Lead Angle	DGI40BU3R	DGI40BC3R	DGI40BD3R	DGI40BE3R	DGI40BF3R		
		7° L.H. Lead Angle	DGI40BU3L	DGI40BC3L	DGI40BD3L	DGI40BE3L	DGI40BF3L		
		.197" (5mm)	Use in all 5mm 'DGP'	Sharp Corner	DGI50BU1	DGI50BC1	DGI50BD1	DGI50BE1	DGI50BF1
				.004" (.10mm) radius	DGI50BU2010	DGI50BC2010	DGI50BD2010	DGI50BE2010	DGI50BF2010
				.008" (.20mm) radius	DGI50BU2020	DGI50BC2020	DGI50BD2020	DGI50BE2020	DGI50BF2020
				.010" (.25mm) radius	DGI50BU2025	DGI50BC2025	DGI50BD2025	DGI50BE2025	DGI50BF2025
				.015" (.38mm) radius	DGI50BU	DGI50BC	DGI50BD	DGI50BE	DGI50BF
.020" (.50mm) radius	DGI50BU2050			DGI50BC2050	DGI50BD2050	DGI50BE2050	DGI50BF2050		
.030" (.75mm) radius	DGI50BU2075			DGI50BC2075	DGI50BD2075	DGI50BE2075	DGI50BF2075		
.040" (1.0mm) radius	DGI50BU2100			DGI50BC2100	DGI50BD2100	DGI50BE2100	DGI50BF2100		
Full Radius	DGI50BU4			DGI50BC4	DGI50BD4	DGI50BE4	DGI50BF4		
15° (+) Top Rake	DGI50BU7P			DGI50BC7P	DGI50BD7P	DGI50BE7P	DGI50BF7P		
15° (-) Top Rake	DGI50BU7N			DGI50BC7N	DGI50BD7N	DGI50BE7N	DGI50BF7N		
7° R.H. Lead Angle	DGI50BU3R			DGI50BC3R	DGI50BD3R	DGI50BE3R	DGI50BF3R		
7° L.H. Lead Angle	DGI50BU3L			DGI50BC3L	DGI50BD3L	DGI50BE3L	DGI50BF3L		
.236" (6mm)	Use in all 6mm 'DGP'	Sharp Corner	DGI60BU1	DGI60BC1	DGI60BD1	DGI60BE1	DGI60BF1		
		.004" (.10mm) radius	DGI60BU2010	DGI60BC2010	DGI60BD2010	DGI60BE2010	DGI60BF2010		
		.008" (.20mm) radius	DGI60BU2020	DGI60BC2020	DGI60BD2020	DGI60BE2020	DGI60BF2020		
		.010" (.25mm) radius	DGI60BU2025	DGI60BC2025	DGI60BD2025	DGI60BE2025	DGI60BF2025		
		.015" (.38mm) radius	DGI60BU	DGI60BC	DGI60BD	DGI60BE	DGI60BF		
		.020" (.50mm) radius	DGI60BU2050	DGI60BC2050	DGI60BD2050	DGI60BE2050	DGI60BF2050		
		.030" (.75mm) radius	DGI60BU2075	DGI60BC2075	DGI60BD2075	DGI60BE2075	DGI60BF2075		
		.040" (1.0mm) radius	DGI60BU2100	DGI60BC2100	DGI60BD2100	DGI60BE2100	DGI60BF2100		
		Full Radius	DGI60BU4	DGI60BC4	DGI60BD4	DGI60BE4	DGI60BF4		
		15° (+) Top Rake	DGI60BU7P	DGI60BC7P	DGI60BD7P	DGI60BE7P	DGI60BF7P		
		15° (-) Top Rake	DGI60BU7N	DGI60BC7N	DGI60BD7N	DGI60BE7N	DGI60BF7N		
		7° R.H. Lead Angle	DGI60BU3R	DGI60BC3R	DGI60BD3R	DGI60BE3R	DGI60BF3R		
		7° L.H. Lead Angle	DGI60BU3L	DGI60BC3L	DGI60BD3L	DGI60BE3L	DGI60BF3L		

DGI STYLE
OD/ID & FACE GROOVING
INSERTS

PRODUCT SELECTION GUIDE - TOOLHOLDERS

TOOLHOLDERS

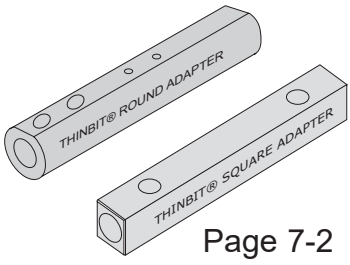
ADAPTERS	 <p style="text-align: right;">Page 7-2</p>
<p>Adapters</p> <ul style="list-style-type: none"> • square and round adapters • Use for boring bars and solid carbide tooling 	

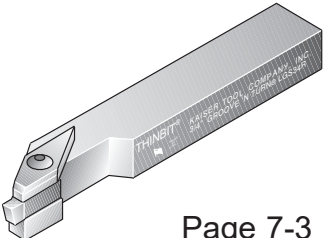

Page 7-3

SWISS, CNC & CONVENTIONAL STYLE	
<p>Straight Square</p> <ul style="list-style-type: none"> • 5/16", 3/8", 1/2", 5/8", 3/4", 1", 1-1/4" and metric shanks • Right and Left Hand • Use for grooving, face grooving, profiling, threading and parting 	<p>90° Square</p> <ul style="list-style-type: none"> • 5/16", 3/8", 1/2", 5/8", 3/4", 1", 1-1/4" and metric shanks • Right and Left Hand • Use for grooving, face grooving, profiling, threading and parting

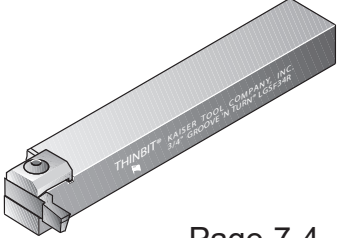

Page 7-4

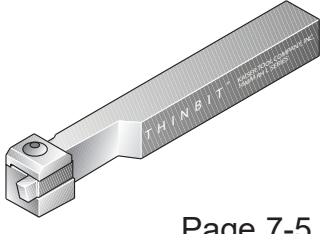

Page 7-5

SWISS STYLE	
<p>Swiss Straight</p> <ul style="list-style-type: none"> • 3/8", 1/2", 10mm, 12mm & 16 mm square shanks • Right and Left Hand • Use for OD grooving, profiling, threading and parting 	<p>Swiss Face</p> <ul style="list-style-type: none"> • 3/8", 1/2", 10mm, 12mm & 16mm square shanks • Right Hand • Use for face grooving

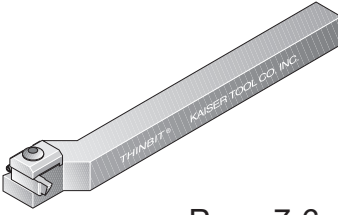

Page 7-6

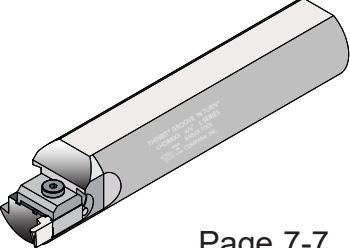

Page 7-7

ROUND STYLE	
<p>Reversible</p> <ul style="list-style-type: none"> • 1/2", 5/8", 3/4" & 1" shanks • Right and Left Hand • Use for grooving, face grooving, profiling, threading and parting 	<p>Internal</p> <ul style="list-style-type: none"> • 1/2", 5/8", 3/4" & 1" shanks • Right and Left Hand • Use for grooving, face grooving, profiling, threading and parting

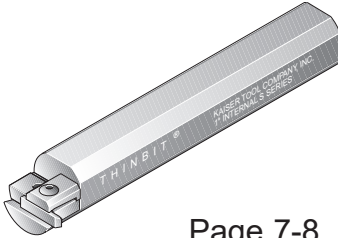

Page 7-8

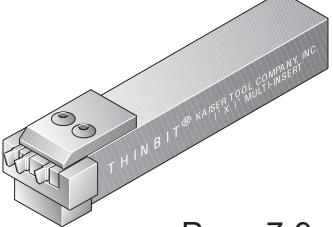

Page 7-9

MULTI-INSERT STYLE	
<p>Square</p> <ul style="list-style-type: none"> • 3/8", 1/2", 5/8", 3/4" & 1" shanks • 1" & 2" pockets • Use for grooving 	<p>Round</p> <ul style="list-style-type: none"> • 1" shank • 1" pocket • Use for grooving

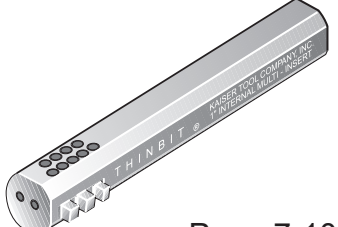

Page 7-10

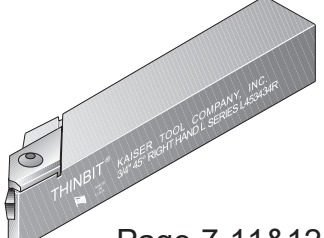

Page 7-11&12

UNDERCUT STYLE	ALTERNATE DGP
<p>45°/30°/60° Square</p> <ul style="list-style-type: none"> • 3/8", 1/2", 5/8", 3/4" and 1" shanks • Right and Left Hand • Use for making undercuts and profiling 	<p>Round & Square</p> <ul style="list-style-type: none"> • Alternate combinations of Deepgroove® heads and shanks • OD/ID grooving • Face grooving

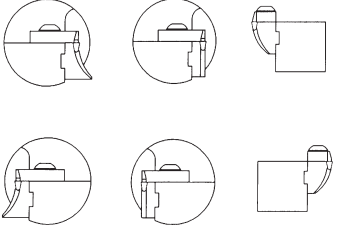

Page 7-15 & 16

KAISER TOOL COMPANY, INC.

Phone: 888-THINBIT (888-844-6248) or (260) 484-3620
 www.thinbit.com • Orders: orders@thinbit.com • Quotes: quotes@thinbit.com

ROUND & SQUARE ADAPTERS

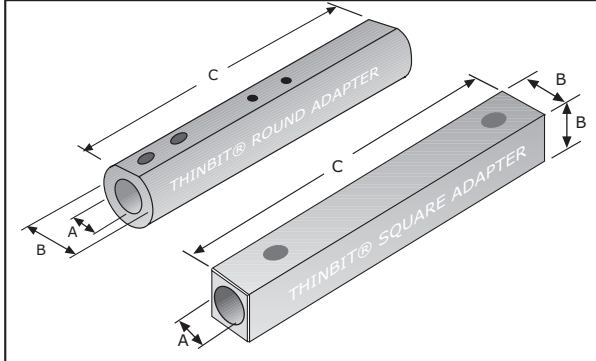
PRODUCT INFORMATION	<ul style="list-style-type: none"> Designed to adapt round tooling to lathe workholding ID sizes 1/8", 5/32", 3/16", 1/4", 5/16" and 3/8". Round sizes 1/4", 3/8", 1/2", 5/8" and 3/4". Square sizes 5/16", 3/8", 1/2", 5/8", 3/4", 1" and 1-1/4". Modifications can be provided on any of our tooling. Please contact us with your application requirements. 	
----------------------------	--	---

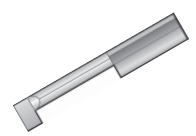
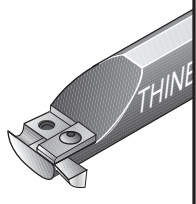
TOOL SELECTIONS	SOLID CARBIDE		GROOVING BARS		BORING BARS	
	Grooving Page 1-3 Face Grooving Page 2-3 Boring Page 3-3 Threading Page 4-3 & 4-5		Grooving Page 1-5 Face Grooving Page 2-5		MBA Page 3-13 MBB Page 3-15 MBC Page 3-17 MBE Page 3-8	MBF Page 3-9 MBG Page 3-10

ORDERING INSTRUCTIONS

Select the **ORDER CODE** in the table below that represents your selection of adapter dimensions.

EXAMPLE:

The **ORDER CODE** for a .375" ID x .625" OD round adapter is:

AD3762

SPECIFICATIONS				ORDER CODE				SPECIFICATIONS				ORDER CODE					
Adapter Style	Shank Dimensions			Adapter	Replacement Parts			Adapter Style	Shank Dimensions			Adapter	Replacement Parts				
	'A'	'B'	'C'		Includes Adapter and Hardware	Screw	Wrench		Pin	'A'	'B'		'C'	Includes Adapter and Hardware	Screw	Wrench	Pin
Round	.125"	3.000"	.250"	AD1225	S1402M	W0050	P0203	Round	.312"	4.000"	.500"	AD3150	S1802	W1005	P0204		
			.375"	AD1237	S1402	W0050	P0203				.625"	AD3162	S1802	W1005	P0206		
			.500"	AD1250	S1402	W0050	P0204				.750"	AD3175	S1802	W1005	P0206		
			.625"	AD1262	S1404	W0050	P0204				1.000"	AD3110	S1804	W1005	P0206		
			.750"	AD1275	S1404	W0050	P0204				.375"	4.000"	.625"	AD3762	S1802	W1005	P0206
			1.000"	AD1210	S1404	W0050	P0204						.750"	AD3775	S1802	W1005	P0206
	.156"	3.000"	.375"	AD1537	S1402M	W0050	---		1.000"	AD3710			S1804	W1005	P0206		
			.500"	AD1550	S1402	W0050	---		.500"	4.000"			.750"	AD5075	S1802	W1005	P0206
			.625"	AD1562	S1403	W0050	---						1.000"	AD5010	S1804	W1005	P0206
	.187"	3.000"	.375"	AD1837	S1402M	W0050	P0203		.750"	1.000"			4.000"	AD7510	S1802	W1005	---
			.500"	AD1850	S1802	W1005	P0204										
			.625"	AD1862	S1802	W1005	P0206										
			.750"	AD1875	S1804	W1005	P0206										
	.250"	4.000"	1.000"	AD1810	S1404	W0050	P0206	Square	.250"	3.000"	.312"	AD56	---	---	---		
			.375"	AD2537	S1402M	W0050	P0203				.375"	AD38	S1802	W1005	---		
			.500"	AD2550	S1802	W1005	P0204		.250" & .375"	3.000"	.500"	AD12	S1802	W1005	---		
.625"			AD2562	S1802	W1005	P0206	.625"				AD58	S1802	W1005	---			
.750"			AD2575	S1804	W1005	P0206	.750"				AD34	S1802	W1005	---			
1.000"	AD2510	S1804	W1005	P0206	1.000"	AD01	S1802				W1005	---					
											1.250"	AD14	S1802	W1005	---		

TOOL HOLDERS

KAISER TOOL COMPANY, INC.

Phone: 888-THINBIT (888-844-6248) or (260) 484-3620
 www.thinbit.com • Orders: orders@thinbit.com • Quotes: quotes@thinbit.com

GROOVE 'N TURN® STRAIGHT TOOLHOLDERS

U.S. PATENT NOS. 6,688,816 and 6,824,333

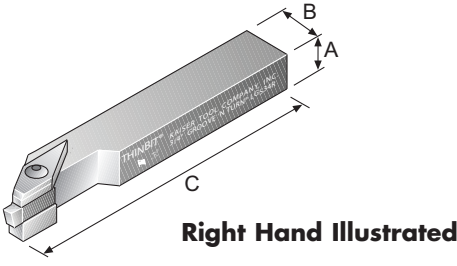
PRODUCT INFORMATION	<ul style="list-style-type: none"> Designed for CNC, conventional and top slide position on Swiss screw machines. Shank sizes 5/16", 3/8", 1/2", 5/8", 3/4", 1" and 1-1/4". Metric sizes also available. Modifications can be provided on any of our tooling. Please contact us with your application requirements. 	 <p>Right Hand Illustrated</p>
----------------------------	--	--

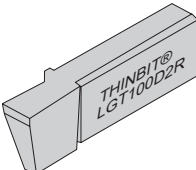
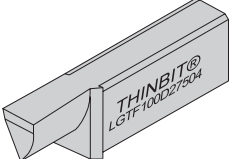
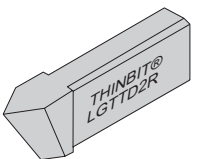
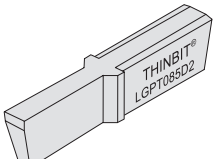
INSERT SELECTIONS	GROOVING	FACE GROOVING	THREADING	PARTING
	 <p>PG 1-9</p>	 <p>PG 2-9</p>	 <p>PG 4-9</p>	 <p>PG 5-3</p>

ORDERING INSTRUCTIONS

Select the **ORDER CODE** in the table below that represents your selection of shank dimensions.

EXAMPLE:

The **ORDER CODE** for a .750" right hand square shank for inserts beginning with 'L' is:

LGS34R

SPECIFICATIONS				ORDER CODE					
Shank Orientation	Shank Dimensions			Toolholder Package <small>Includes Shank, Clamp and Hardware</small>		Replacement Parts			
	'A'	'B'	'C'	For Inserts Beginning With 'L'		Clamp	Screw	Wrench	Pin
			RIGHT HAND	LEFT HAND					
Straight Use right hand holder with right hand inserts Use left hand holder with left hand inserts	.312"	.500"	4.840"	LGS56R	LGS56L	Right Hand: Clamp X	S3808	W1005	*P0206
	.375"	.500"	4.840"	LGS38R	LGS38L				
	.500"	.500"	4.840"	LGS12R	LGS12L				
	.625"	.625"	4.840"	LGS58R	LGS58L				
	.750"	.750"	4.840"	LGS34R	LGS34L				
	1.000"	1.000"	4.840"	LGS01R	LGS01L				
	8mm	.500"	4.840"	LGS08RM	LGS08LM	Left Hand: Clamp Y	S3808	W1005	*P0306
	10mm	.500"	4.840"	LGS10RM	LGS10LM				
	12mm	.500"	4.840"	LGS12RM	LGS12LM				
	16mm	.750"	4.840"	LGS16RM	LGS16LM				
	20mm	1.000"	4.840"	LGS20RM	LGS20LM				
	25mm	1.000"	4.840"	LGS25RM	LGS25LM				

*Both pins will be shipped on replacement orders.

KAISER TOOL COMPANY, INC.

Phone: 888-THINBIT (888-844-6248) or (260) 484-3620
 www.thinbit.com • Orders: orders@thinbit.com • Quotes: quotes@thinbit.com

PRODUCT INFORMATION	<ul style="list-style-type: none"> Designed for CNC and conventional machines. Shank sizes 5/16", 3/8", 1/2", 5/8", 3/4", 1" and 1-1/4". Metric sizes also available. Modifications can be provided on any of our tooling. Please contact us with your application requirements. 	<p>Right Hand Illustrated</p>
----------------------------	---	--------------------------------------

INSERT SELECTIONS	GROOVING	FACE GROOVING	THREADING	PARTING
	<p>PG 1-9</p>	<p>PG 2-9</p>	<p>PG 4-9</p>	<p>PG 5-3</p>

ORDERING INSTRUCTIONS

Select the **ORDER CODE** in the table below that represents your selection of shank orientation and dimensions.

EXAMPLE:

The **ORDER CODE** for a .750" right hand shank for inserts beginning with 'L' is:

LGSF34R

SPECIFICATIONS				ORDER CODE					
Shank Orientation	Shank Dimensions			Toolholder Package <small>Includes Shank, Clamp and Hardware For Inserts Beginning With 'L'</small>		Replacement Parts			
	'A'	'B'	'C'	RIGHT HAND	LEFT HAND	Clamp	Screw	Wrench	Pin
90° Use right hand holder with left hand inserts	.312"	.500"	4.840"	LGSF56R		Clamp C	S3808	W1005	P0312
	.375"	.500"	4.840"	LGSF38R					
	.500"	.500"	4.840"	LGSF12R					
	.625"	.625"	4.840"	LGSF58R	LGSF58L				
	.750"	.750"	4.840"	LGSF34R	LGSF34L				
	1.000"	1.000"	4.840"	LGSF01R	LGSF01L				
	1.250"	1.250"	4.840"	LGSF14R	LGSF14L				
Use left hand holder with right hand inserts	8mm	.500"	4.840"	LGSF08RM					
	10mm	.500"	4.840"	LGSF10RM					
	12mm	.500"	4.840"	LGSF12RM					
	16mm	.750"	4.840"	LGSF16RM	LGSF16LM				
	20mm	1.000"	4.840"	LGSF20RM	LGSF20LM				
	25mm	1.000"	4.840"	LGSF25RM	LGSF25LM				

**GROOVE 'N TURN®
TOOLHOLDERS**

KAISER TOOL COMPANY, INC.

Phone: 888-THINBIT (888-844-6248) or (260) 484-3620
www.thinbit.com • Orders: orders@thinbit.com • Quotes: quotes@thinbit.com

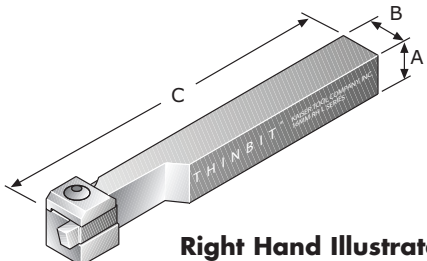
PRODUCT INFORMATION	<ul style="list-style-type: none"> Designed for top slide position on Swiss screw machines. Shank sizes 1/2", 12mm and 16mm in right hand orientation. Modifications can be provided on any of our tooling. Please contact us with your application requirements. 	 <p>Right Hand Illustrated</p>
----------------------------	--	--

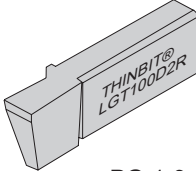
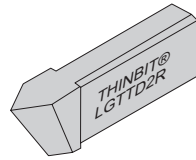
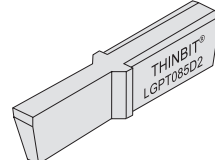
INSERT SELECTIONS	GROOVING	THREADING	PARTING
	 PG 1-9	 PG 4-9	 PG 5-3

ORDERING INSTRUCTIONS

Select the **ORDER CODE** in the table below that represents your selection of shank orientation and dimensions.

EXAMPLE:

The **ORDER CODE** for a .500" shank, right hand tool for inserts beginning with 'L' is:

LSS12R

SPECIFICATIONS				ORDER CODE				
Shank Orientation	Shank Dimensions			Toolholder Package Includes Shank, Clamp and Hardware For Inserts Beginning With 'L'	Replacement Parts			
	'A'	'B'	'C'		Clamp	Screw	Wrench	Pin
Right Hand	.500"	.500"	4.840"	LSS12R	Clamp C	S3808	W1005	P0305
Use with right hand and centered inserts	12mm	12mm		LSS12RM				
	16mm	16mm		LSS16RM				
Left Hand	.500"	.500"	4.840"	LSS12L				
Use with left hand and centered inserts	12mm	12mm		LSS12LM				
	16mm	16mm		LSS16LM				

KAISER TOOL COMPANY, INC.

Phone: 888-THINBIT (888-844-6248) or (260) 484-3620
www.thinbit.com • Orders: orders@thinbit.com • Quotes: quotes@thinbit.com

PRODUCT INFORMATION

- Designed for top slide position on Swiss screw machines.
- Shank sizes 3/8", 1/2", 10mm, 12mm and 16mm in right hand orientation.
- Modifications can be provided on any of our tooling. Please contact us with your application requirements.

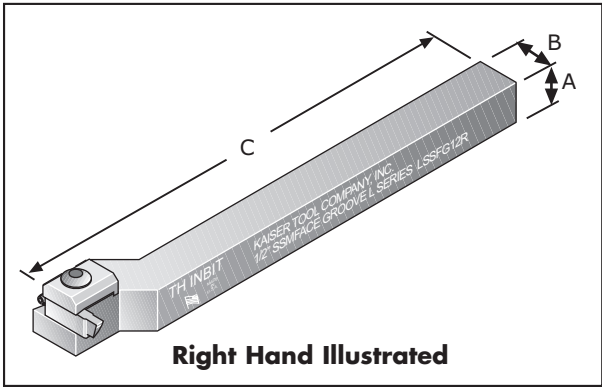

FACE GROOVING

INSERT SELECTIONS

PG 2-9

ORDERING INSTRUCTIONS

Select the **ORDER CODE** in the table below that represents your selection of shank orientation and dimensions.

EXAMPLE:

The **ORDER CODE** for a .375" right hand shank for inserts beginning with 'L' is:

LSSFG38R

SPECIFICATIONS				ORDER CODE				SWISS TOOLHOLDERS	
Shank Orientation	Shank Dimensions			Toolholder Package Includes Shank, Clamp and Hardware For Inserts Beginning With 'L'	Replacement Parts				
	'A'	'B'	'C'		Clamp	Screw	Wrench		Pin
Right Hand Use with left hand and centered inserts for counter-clockwise rotation	.375"	.375"	4.840"	LSSFG38R	Clamp C	S3808	W1005	P0203	
	.500"	.500"	4.840"	LSSFG12R					
	10mm	10mm	4.840"	LSSFG10RM					
	12mm	12mm	4.840"	LSSFG12RM					
	16mm	16mm	4.840"	LSSFG16RM					

KAISER TOOL COMPANY, INC.

Phone: 888-THINBIT (888-844-6248) or (260) 484-3620
 www.thinbit.com • Orders: orders@thinbit.com • Quotes: quotes@thinbit.com

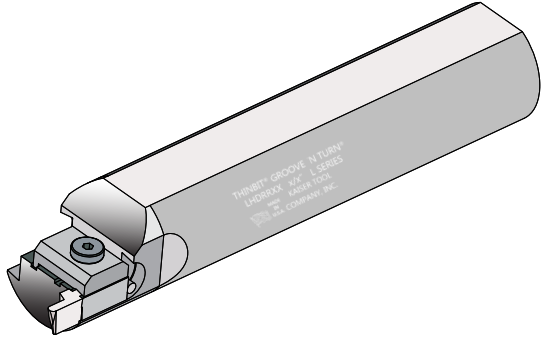
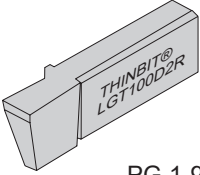
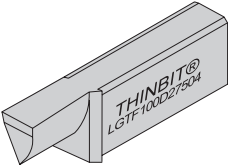
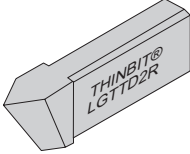
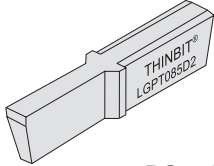
PRODUCT INFORMATION	<ul style="list-style-type: none"> Designed for boring bar positions on all machines. Can be used with a boring head to trepan on a mill. Shank may need to be shortened. Toolholder reversible by changing clamp to other side. Shank sizes 12mm, 1/2", 5/8", 16mm, 3/4", 20mm, 22mm, 25mm and 1". All 1/2", 5/8" and 3/4" shanks are made from 1" shank. For a shortened shank see page 11-2. Modifications can be provided on any of our tooling. Please contact us with your application requirements. 				 <p>Heavy Duty Round Reversible Toolholder</p>	
	INSERT SELECTIONS	GROOVING	FACE GROOVING	THREADING	PARTING	
 PG 1-9		 PG 2-9	 PG 4-9	 PG 5-3		

ORDERING INSTRUCTIONS

Select the **ORDER CODE** in the table below that represents your selection of shank dimensions.

EXAMPLE:

The **ORDER CODE** for a 3/4" round shank for inserts beginning with 'L' is:

LHDRR34

SPECIFICATIONS		ORDER CODE		
Shank Orientation	Shank Dimensions	Toolholder Package Includes Shank, Clamp and Hardware		
		For Inserts Beginning With 'L'	Clamp	Clamp Hardware
<p style="text-align: center;">Right Hand or Left Hand</p> <p>Use as right hand with right hand inserts</p> <p>Use as left hand with left hand inserts</p> <p>Use as either hand with centered inserts</p>	1/2"	LHDRR12	Clamp C	Screw: S3808 Wrench: W1005 Pin: P0305
	5/8"	LHDRR58		
	3/4"	LHDRR34		
	1"	LHDRR01		
	12 mm	LHDRR12M		
	16 mm	LHDRR16M		
	20 mm	LHDRR20M		
	22 mm	LHDRR22M		
	25 mm	LHDRR25M		

KAISER TOOL COMPANY, INC.

Phone: 888-THINBIT (888-844-6248) or (260) 484-3620
www.thinbit.com • Orders: orders@thinbit.com • Quotes: quotes@thinbit.com

PRODUCT INFORMATION	<ul style="list-style-type: none"> • Designed for boring bar positions on all machines. • Toolholder reversible for left and right hand orientation. • Shank sizes 1/2", 5/8", 3/4" and 1". • All 1/2", 5/8" and 3/4" shanks are made from 1" shank. • Modifications can be provided on any of our tooling. Please contact us with your application requirements.
----------------------------	--

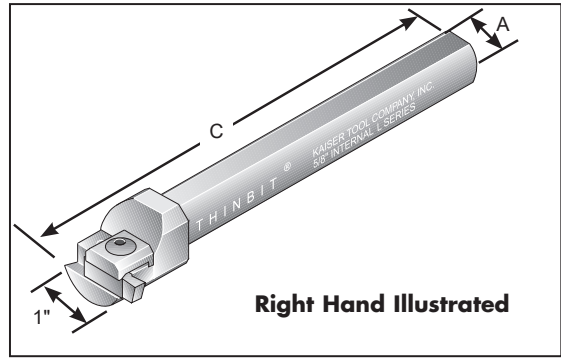

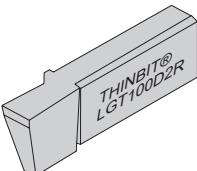
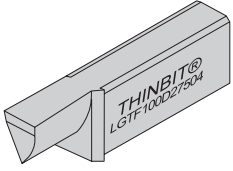
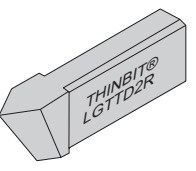
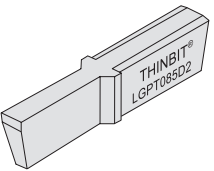
INSERT SELECTIONS	GROOVING	FACE GROOVING	THREADING	PARTING
	 PG 1-9	 PG 2-9	 PG 4-9	 PG 5-3

ORDERING INSTRUCTIONS

Select the **ORDER CODE** in the table below that represents your selection of shank orientation and dimensions.

EXAMPLE:

The **ORDER CODE** for a .625" right hand shank for inserts beginning with 'L' is:
LR5806

SPECIFICATIONS				ORDER CODE				
Shank Orientation	Minimum Bore Diameter	Shank Dimensions		Toolholder Package Includes Shank, Clamp and Hardware	Replacement Parts			
		'A'	'C'		For Inserts Beginning With 'L'			
	without pin				Clamp	Screw	Wrench	Pin
Right Hand or Left Hand Use as right hand with left hand inserts; Use as left hand with right hand inserts; Use as either hand with centered inserts.	1.250"	.500"	5.500"	LR1206	Clamp C	S3808	W1005	P0305
		.625"		LR5806				
		.750"		LR3406				
		1.000"	5.500"	LR0106				
			11.875"	LR0112				
		.787"	5.500"	LR01015M				
		.984"		LR02515M				

ROUND TOOLHOLDERS

KAISER TOOL COMPANY, INC.

Phone: 888-THINBIT (888-844-6248) or (260) 484-3620
www.thinbit.com • Orders: orders@thinbit.com • Quotes: quotes@thinbit.com



MULTI-INSERT SQUARE TOOLHOLDERS

PRODUCT INFORMATION

- Designed to reduce cycle time on those machines with adequate horsepower to handle the tool pressure.
- Pocket is filled with any selection of insert geometry and lengths. Proper edge to edge relation maintained with spacer blocks.
- Shank sizes 3/8", 1/2", 5/8", 3/4" and 1".
- Pocket sizes 1" and 2".
- Modifications can be provided on any of our tooling. Please contact us with your application requirements.

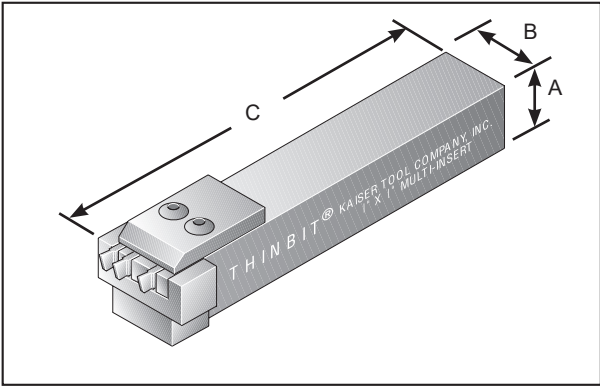

INSERT SELECTION

Due to the potential complexity of configuring these toolholders, we recommend calling for assistance.
See Page 8-7

ORDERING INSTRUCTIONS

Select the **ORDER CODE** in the table below that represents your selection of shank dimensions.

EXAMPLE:

The **ORDER CODE** for a 1" pocket on a 1" square shank is:

EM010101

SPECIFICATIONS				ORDER CODE						
Pocket Size	Shank Dimensions			Toolholder Package Includes Shank, Pocket, Clamp and Hardware	Replacement Parts					
	'A'	'B'	'C'		Call For Inserts	Pocket Includes Hardware	Pocket Hardware	Backplate	Shank	Clamp
1" Pocket	.375"	1.000"	4.840"	EM013801	HM0101	Screw: 2 each S1604 S3810	---	ESM0138	Clamp M	Screw: 2 each S3808
	.500"			EM011201				ESM0112		
	.625"			EM015801				ESM0158		
	.750"			EM013401				ESM0134		
	1.000"			EM010101				ESM0101		
2" Pocket	.375"	1.000"	4.840"	EM013802	HM0102	Wrench: 1 each: W1004 W1005	Backplate: BP0002	ESM0138	Clamp N	Wrench: W1005
	.500"			EM011202			ESM0112			
	.625"			EM015802			ESM0158			
	.750"			EM013402			ESM0134			
	1.000"			EM010102			ESM0101			

KAISER TOOL COMPANY, INC.

Phone: 888-THINBIT (888-844-6248) or (260) 484-3620
www.thinbit.com • Orders: orders@thinbit.com • Quotes: quotes@thinbit.com

PRODUCT INFORMATION

- Designed to reduce cycle time on those machines with adequate horsepower to handle the tool pressure.
- Pocket is filled with any selection of insert geometry and lengths. Proper edge to edge relation maintained with spacer blocks.
- Shank size 1".
- Pocket size 1".
- Modifications can be provided on any of our tooling. Please contact us with your application requirements.

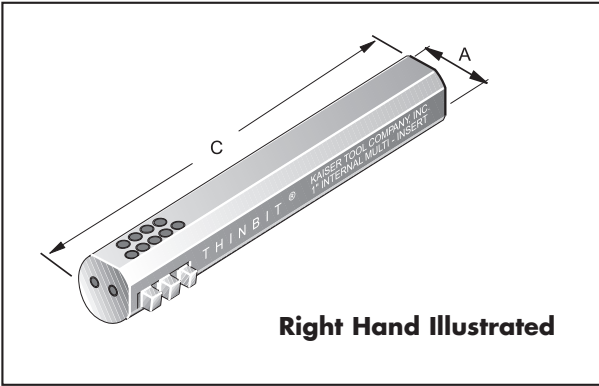

INSERT SELECTION

Due to the potential complexity of configuring these toolholders, we recommend calling for assistance.
See Page 8-7

ORDERING INSTRUCTIONS

Select the **ORDER CODE** in the table below that represents your selection of shank dimensions.

EXAMPLE:

The **ORDER CODE** for a 1" right hand shank, 5.5" long is:

ROM0106

SPECIFICATIONS				ORDER CODE				
Pocket Size & Shank Orientation	Minimum Bore Diameter	Shank Dimensions		Toolholder Package Includes Shank and Hardware	Replacement Parts			
		'A'	'C'		Call For Inserts	End Screws	Clamping Screws	Wrench
1" Pocket Right Hand	1.125" Varies depending on configuration	1.000"	5.500"	ROM0106	2 each: S1804	9 each: S1808	W1005	P0001
			11.875"	ROM0112				

MULTI-INSERT TOOLHOLDERS

KAISER TOOL COMPANY, INC.

Phone: 888-THINBIT (888-844-6248) or (260) 484-3620
www.thinbit.com • Orders: orders@thinbit.com • Quotes: quotes@thinbit.com

GROOVE 'N TURN[®] 45° & 30° & 60° TOOLHOLDERS

U.S. PATENT NOS. 6,688,816 and 6,824,333

PRODUCT INFORMATION

- Designed for making angled undercuts.
- Toolholder must be used with inserts that have radial relief.
- Groove widths less than .080" may require a special insert.
- Shank sizes 3/8", 1/2", 5/8", 3/4" and 1".
- Modifications can be provided on any of our tooling. Please contact us with your application requirements.

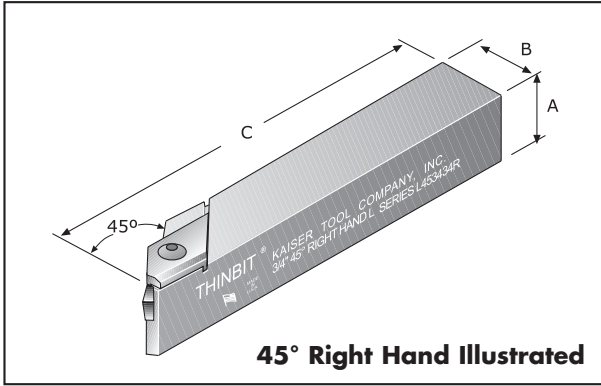

INSERT SELECTIONS

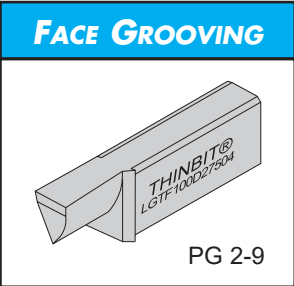

Due to the potential complexity of configuring these toolholders, we recommend calling for assistance.

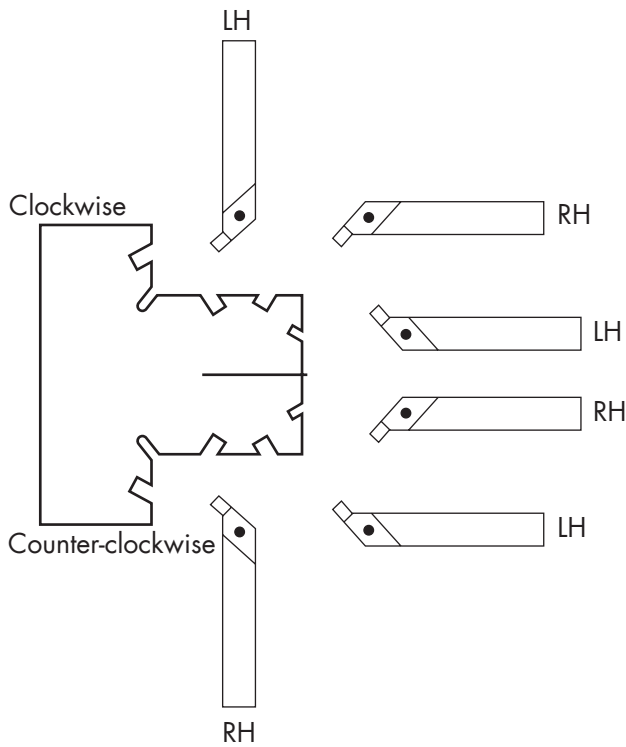

APPLICATION EXAMPLES
TOP VIEW, CUTTING EDGE UP

45° ILLUSTRATED

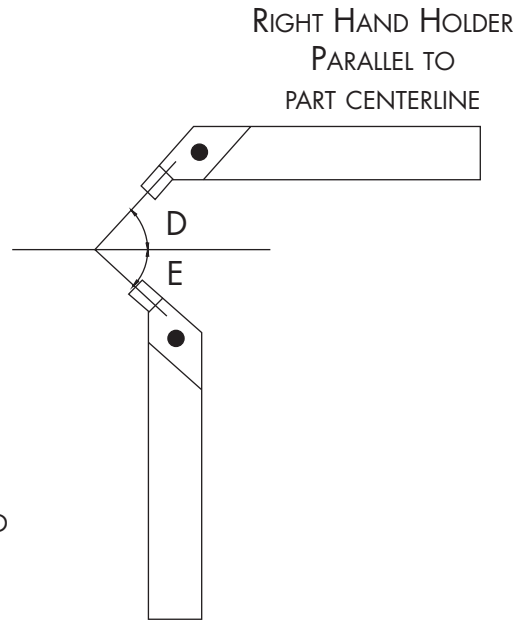

KAISER TOOL COMPANY, INC.







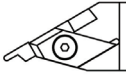
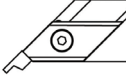
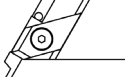

Phone: 888-THINBIT (888-844-6248) or (260) 484-3620
www.thinbit.com • Orders: orders@thinbit.com • Quotes: quotes@thinbit.com

ORDERING INSTRUCTIONS

Select the **ORDER CODE** in the table below that represents your selection of shank orientation and dimensions.

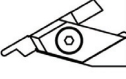
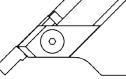
EXAMPLE:

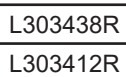
The **ORDER CODE** for a 45° holder with a .750" right hand shank is:
L453434R

SPECIFICATIONS (Page 7-11)				ORDER CODE								
Shank Orientation	Shank Dimensions			Toolholder Package Includes Shank, Clamp and Hardware								
	Height "A"	Width "B"	Length "C"	Shank Angle "D" = 30° "E" = 60°	Clamp	Shank Angle "D" = 45° "E" = 45°	Clamp	Shank Angle "D" = 60° "E" = 30°	Clamp	Hardware		
Right Hand Inserts are application specific (See page 7-11)	.375"	.750"	4.840"		Clamp Y		Clamp Q		Clamp Y	Screw: S3808 Wrench: W1005 Pin: P0305 *C0509		
	.500"			L303438R		L453438R		L363438R				
	.625"			L303412R		L453412R		L363412R				
	.750"			L303458R		L453458R		L363458R				
	1.00"			L303434R		L453434R		L363434R				
Left Hand Inserts are application specific (See page 7-11)	.375"	.750"	4.840"		Clamp X		Clamp R		Clamp X	Screw: S3808 Wrench: W1005 Pin: P0305 *C0509		
	.500"			L303438L		L453438L		L363438L				
	.625"			L303412L		L453412L		L363412L				
	.750"			L303458L		L453458L		L363458L				
	1.00"			L303434L		L453434L		L363434L				
Right Hand Swiss Angle Style Inserts are application specific (See page 7-11)	.375"	.750"	4.840"		Clamp Y		Clamp Y		Clamp Y	Screw: S3808 Wrench: W1005 Pin: P0305 *C0509		
	.500"			L303438R		L453438R		L363438R				
	.625"			L303412R		L453412R		L363412R				
	.750"			L303458R		L453458R		L363458R				
	1.00"			L303434R		L453434R		L363434R				
	10mm	L300101R	L450101R	L360101R								
	12mm	L303410RM	L453410RM	L363410RM								
	16mm	L303412RM	L453412RM	L363412RM								
	16mm	L303416RM	L453416RM	L363416RM								
	.375"	.902"	4.840"		Clamp Y		Clamp Y		Clamp Y		LSS4538R	LSS6038R
	.500"										LSS4512R	LSS6012R
	10mm										LSS4510RM	LSS6010RM
	12mm										LSS4512RM	LSS6012RM
16mm	LSS4516RM									LSS6016RM		

*Roll Pin sizes may have changed due to manufacturing updates. Toolholders will be shipped with the correct item. Replacement pin (C0509) will contain two items (P0204 & P0305) to accommodate either version.

KAISER TOOL COMPANY, INC.

Phone: 888-THINBIT (888-844-6248) or (260) 484-3620
 www.thinbit.com • Orders: orders@thinbit.com • Quotes: quotes@thinbit.com

**45° & 30° & 60°
TOOLHOLDERS**

GROOVE 'N TURN® 45° & 30° & 60° TOOLHOLDERS

PRODUCT INFORMATION	<ul style="list-style-type: none"> • Designed for CNC, conventional and end working position on Swiss screw machines. • Position the insert at 30°, 45° or 60° angles for reliefs, undercuts and angled OD and face grooves. • Shank sizes 1/2", 5/8", 3/4", 1", 20mm and 25mm. • For use with THINBIT® inserts - See pages 2-9 & 2-10. • Modifications can be provided on any of our tooling. Please contact us with your application requirements. 	<p style="text-align: right;">45° Right Hand Illustrated</p>
----------------------------	---	---

INSERT SELECTIONS	FACE GROOVING	<p style="text-align: center;">PG 2-9</p>	<p>Due to the potential complexity of configuring these toolholders, we recommend calling for assistance.</p>
--------------------------	----------------------	---	---

APPLICATION EXAMPLES TOP VIEW, CUTTING EDGE UP

D = Insert angle when toolholder centerline is parallel to centerline.
E = Insert angle when toolholder centerline is perpendicular to part centerline.

Left Hand Holders			Right Hand Holders
	<p>30° D=30° E=60°</p>		
<p>Custom inserts are required for internal grooving.</p>			
	<p>45° D=45° E=45°</p>		
<p>1.125 Minimum bore required for internal grooving.</p>			
	<p>60° D=60° E=30°</p>		
<p>1.170 Minimum bore required for internal grooving.</p>			

KAISER TOOL COMPANY, INC.

Phone: 888-THINBIT (888-844-6248) or (260) 484-3620
www.thinbit.com • Orders: orders@thinbit.com • Quotes: quotes@thinbit.com

ORDERING INSTRUCTIONS

Select the **ORDER CODE** in the table below that represents your selection of shank orientation and dimensions.

EXAMPLE:

The **ORDER CODE** for a 45° holder with a 3/4" right hand shank is:

LR4534R

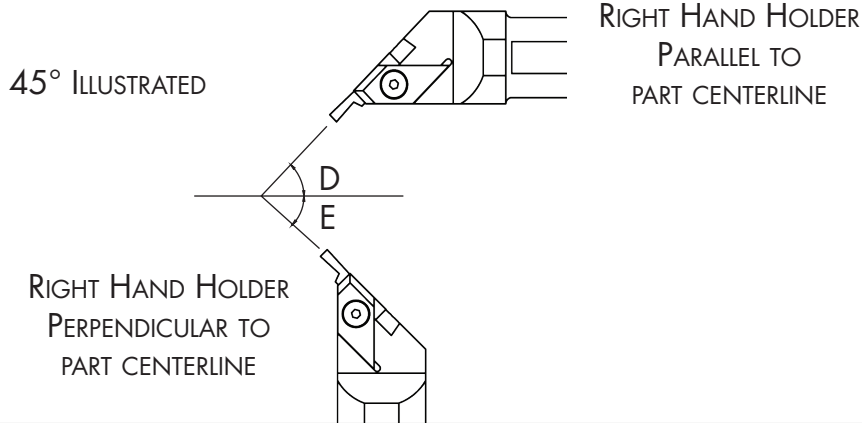

SPECIFICATIONS (Page 7-13)		ORDER CODE					
Shank Orientation	Shank Size	Toolholder Package Includes Shank, Clamp and Hardware Shank Angle			Length	Replacement Parts	
	"A"	"D" = 30° "E" = 60°	"D" = 45° "E" = 45°	"D" = 60° "E" = 30°		Clamp	Hardware
Right Hand Inserts are application specific (See page 7-13)					5"	Clamp Y	Screw: S3808 Wrench: W1005
	.500"	LR3012R	LR4512R	LR6012R			
	.625"	LR3058R	LR4558R	LR6058R			
	.750"	LR3034R	LR4534R	LR6034R			
	1.00"	LR3001R	LR4501R	LR6001R			
	20mm	LR3020RM	LR4520RM	LR6020RM			
	25mm	LR3025RM	LR4525RM	LR6025RM			
Left Hand Inserts are application specific (See page 7-13)					5"	Clamp X	Pin: P0305
	.500"	LR3012L	LR4512L	LR6012L			
	.625"	LR3058L	LR4558L	LR6058L			
	.750"	LR3034L	LR4534L	LR6034L			
	1.00"	LR3001L	LR4501L	LR6001L			
	20mm	LR3020LM	LR4520LM	LR6020LM			
	25mm	LR3025LM	LR4525LM	LR6025LM			

**45° & 30° & 60°
TOOLHOLDERS**

KAISER TOOL COMPANY, INC.

Phone: 888-THINBIT (888-844-6248) or (260) 484-3620
www.thinbit.com • Orders: orders@thinbit.com • Quotes: quotes@thinbit.com

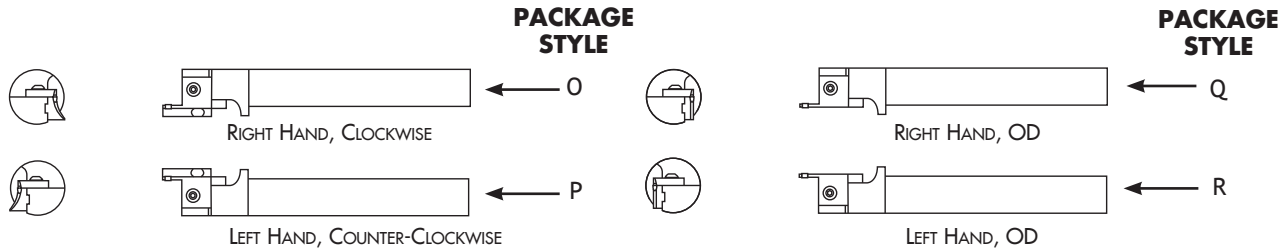

SPECIFICATIONS				ORDER CODE												
Insert Width	Depth of Cut	Package Style	Inserts Page 6-1 Use Inserts Beginning With	Toolholder Package Includes Shank, Head, Clamp and Hardware			Inserts Use Inserts Beginning With	Replacement Parts								
				3/4" Shank 3/4"Ø x 7"	1" Shank 1"Ø x 7"	Metric Shanks 20=20x1"x125mm 25=25x1"x125mm		Head	Head Hardware	Shank 34 = 3/4" 01 = 1" 20 = 20mm 25 = 25mm	Clamp	Clamp Hardware				
2mm (.078")	13mm (1/2")	O	'DGI2'	DGPO201334__	DGPO201301__	DGPO2013_____	'DGI2' (Page 6-1)	DGH32013__	Screw: 2 each S7552	DGS__ZR	DGC12013	Screw: S6552				
		Q*		DGPQ201334	DGPQ201301	DGPQ2013__		DGH12013		DGS__ZL	DGC22013					
		P		DGPP201334__	DGPP201301__	DGPP2013_____		DGH42013__		DGS__ZR	DGC13013					
		R*		DGPR201334	DGPR201301	DGPR2013__		DGH22013		DGS__ZL	DGC23013					
3mm (.118")	13mm (1/2")	O	Use 'DGMI3' for major diameter codes '02' & '25' 'DGI3' for all others	DGPO301334__	DGPO301301__	DGPO3013_____	Use 'DGMI3' for major diameter codes '02' & '25' 'DGI3' for all others (Page 6-1)	DGH33013__		Screw: 2 each S7552	DGS__ZR		DGC13013	Screw: S6552		
		Q*		DGPQ301334	DGPQ301301	DGPQ3013__		DGH13013			DGS__ZL		DGC23013			
		P		DGPP301334__	DGPP301301__	DGPP3013_____		DGH43013__			DGS__ZR		DGC14013			
		R*		DGPR301334	DGPR301301	DGPR3013__		DGH23013			DGS__ZL		DGC24013			
4mm (.157")	13mm (1/2")	O	Use 'DGMI4' for major diameter codes '02' & '25' 'DGI4' for all others	DGPO401334__	DGPO401301__	DGPO4013_____	Use 'DGMI4' for major diameter codes '02' & '25' 'DGI4' for all others (Page 6-1)	DGH34013__			Screw: 2 each S7552		DGS__ZR		DGC14013	Screw: S6552
		Q*		DGPQ401334	DGPQ401301	DGPQ4013__		DGH14013					DGS__ZL		DGC24013	
		P		DGPP401334__	DGPP401301__	DGPP4013_____		DGH44013__					DGS__ZR		DGC14020	
		R*		DGPR401334	DGPR401301	DGPR4013__		DGH24013					DGS__ZL		DGC24020	
	20mm (3/4")	O		DGPO402034__	DGPO402001__	DGPO4020_____		DGH34020__	DGS__ZR			DGC14020				
		Q*		DGPQ402034	DGPQ402001	DGPQ4020__		DGH14020	DGS__ZL			DGC24020				
		P		DGPP402034__	DGPP402001__	DGPP4020_____		DGH44020__	DGS__ZR			DGC15013				
		R*		DGPR402034	DGPR402001	DGPR4020__		DGH24020	DGS__ZL			DGC24020				
5mm (.197")	13mm (1/2")	O	'DGI5'	DGPO501334__	DGPO501301__	DGPO5013_____	'DGI5' (Page 6-1)	DGH35013__	Wrench: W4025	DGS__ZR		DGC15013	Wrench: W4025			
		Q*		DGPQ501334	DGPQ501301	DGPQ5013__		DGH15013		DGS__ZL		DGC25013				
		P		DGPP501334__	DGPP501301__	DGPP5013_____		DGH45013__		DGS__ZR		DGC15025				
		R*		DGPR501334	DGPR501301	DGPR5013__		DGH25013		DGS__ZL		DGC25025				
	25mm (1")	O		DGPO502534__	DGPO502501__	DGPO5025_____		DGH35025__		DGS__ZR	DGC15025					
		Q*		DGPQ502534	DGPQ502501	DGPQ5025__		DGH15025		DGS__ZL	DGC25025					
		P		DGPP502534__	DGPP502501__	DGPP5025_____		DGH45025__		DGS__ZR	DGC16013					
		R*		DGPR502534	DGPR502501	DGPR5025__		DGH25025		DGS__ZL	DGC25025					
6mm (.236")	13mm (1/2")	O	'DGI6'	DGPO601334__	DGPO601301__	DGPO6013_____	'DGI6' (Page 6-1)	DGH36013__		Wrench: W4025	DGS__ZR	DGC16013		Wrench: W4025		
		Q*		DGPQ601334	DGPQ601301	DGPQ6013__		DGH16013			DGS__ZL	DGC26013				
		P		DGPP601334__	DGPP601301__	DGPP6013_____		DGH46013__			DGS__ZR	DGC16025				
		R*		DGPR601334	DGPR601301	DGPR6013__		DGH26013			DGS__ZL	DGC26025				
	25mm (1")	O		DGPO602534__	DGPO602501__	DGPO6025_____		DGH36025__	DGS__ZR		DGC16025					
		Q*		DGPQ602534	DGPQ602501	DGPQ6025__		DGH16025	DGS__ZL		DGC26025					
		P		DGPP602534__	DGPP602501__	DGPP6025_____		DGH46025__	DGS__ZR		DGC16025					
		R*		DGPR602534	DGPR602501	DGPR6025__		DGH26025	DGS__ZL		DGC26025					

* Codes not required on Q and R packages

Major Diameter Range	Insert Width	Code	Insert Style	Major Diameter Range	Insert Width	Code	Insert Style	
.787"-.885" (20-22.5mm)	2mm	02	DGI	1.377"-1.574" (35-40mm)	2mm	50	DGI	
	3 & 4mm	02	DGMI		3, 4, 5 & 6mm	34	DGI	
.885"-.984" (22.5-25mm)	2mm	25	DGI		1.574"-1.968" (40-50mm)		45	DGI
	3 & 4mm	25	DGMI		1.968"-2.362" (50-60mm)		56	DGI
.984"-1.082" (25-27.5mm)	2mm	57	DGI		2.362"-2.952" (60-75mm)	All	67	DGI
	3, 4, 5 & 6mm	23	DGI		2.952"-3.937" (75-100mm)		71	DGI
1.082"-1.181" (27.5-30mm)	2mm	70	DGI		3.937"-5.905" (100-150mm)		11	DGI
	3, 4, 5 & 6mm	23	DGI		5.905"-11.811" (150-300mm)		13	DGI
1.181"-1.377" (30-35mm)	2mm	05	DGI	11.811"-∞ (300mm-∞)	30		DGI	
	3, 4, 5 & 6mm	34	DGI					

Note:
As long as first plunge is made within major diameter range and each following plunge overlaps, groove width can be increased toward or away from center of part.

DEEPGROOVE[®] SQUARE SHANKS WITH INTERNAL FACE GROOVING HEADS

U.S. PATENT NO. 5,638,728

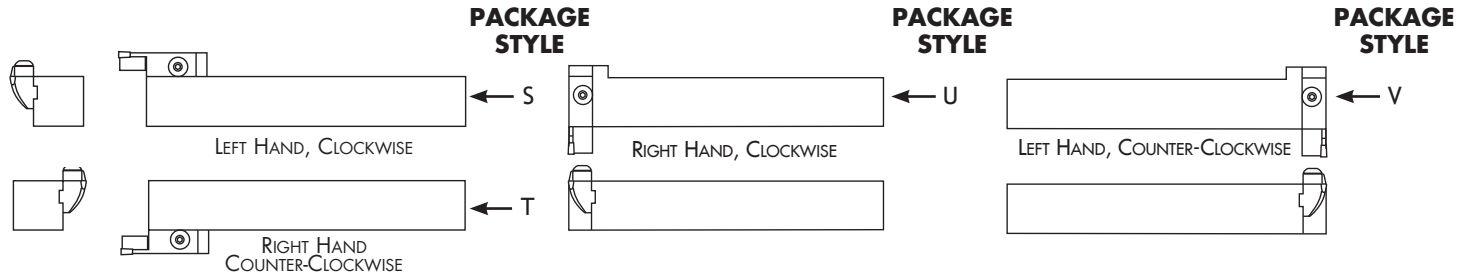

SPECIFICATIONS			ORDER CODE									
Insert Width	Depth of Cut	Package Style See Above	Toolholder Package Includes Shank, Head, Clamp and Hardware			Inserts Use Inserts Beginning With	Replacement Parts					
			3/4" Shank 3/4"x3/4"x5"	1" Shank 1"x1"x5"	Metric Shanks 16 = 16x16x125mm 20 = 20x1"x125mm 25 = 25x1"x125mm		Head	Head Hardware	Shank 34 = 3/4" 01 = 1" 16 = 16mm 20 = 20mm 25 = 25mm	Clamp	Clamp Hardware	
2mm (.078")	13mm (1/2")	S	DGPS201334__	DGPS201301__	DGPS2013__	'DGI2' (Page 6-1)	DGH52013__ DGH62013__		DGS__XL	DGC52013		
		U	DGPU201334__	DGPU201301__	DGPU2013__				DGS__YR			
		T	DGPT201334__	DGPT201301__	DGPT2013__				DGS__XR			DGC62013
		V	DGPV201334__	DGPV201301__	DGPV2013__				DGS__YL			
3mm (.118")	13mm (1/2")	S	DGPS301334__	DGPS301301__	DGPS3013__	'DGI3' (Page 6-1)	DGH53013__ DGH63013__		DGS__XL	DGC53013		
		U	DGPU301334__	DGPU301301__	DGPU3013__				DGS__YR			
		T	DGPT301334__	DGPT301301__	DGPT3013__				DGS__XR			DGC63013
		V	DGPV301334__	DGPV301301__	DGPV3013__				DGS__YL			
4mm (.157")	13mm (1/2")	S	DGPS401334__	DGPS401301__	DGPS4013__	'DGI4' (Page 6-1)	DGH54013__ DGH64013__	Screw: 2 each S7552	DGS__XL	DGC54013		
		U	DGPU401334__	DGPU401301__	DGPU4013__				DGS__YR			
		T	DGPT401334__	DGPT401301__	DGPT4013__				DGS__XR			DGC64013
		V	DGPV401334__	DGPV401301__	DGPV4013__				DGS__YL			
	20mm (3/4")	S	DGPS402034__	DGPS402001__	DGPS4020__		DGH54020__ DGH64020__		DGS__XL	DGC54020		
		U	DGPU402034__	DGPU402001__	DGPU4020__				DGS__YR			
		T	DGPT402034__	DGPT402001__	DGPT4020__				DGS__XR			DGC64020
		V	DGPV402034__	DGPV402001__	DGPV4020__				DGS__YL			
5mm (.197")	13mm (1/2")	S	DGPS501334__	DGPS501301__	DGPS5013__	'DGI5' (Page 6-1)	DGH55013__ DGH65013__	Wrench: W4025	DGS__XL	DGC55013	Wrench: W4025	
		U	DGPU501334__	DGPU501301__	DGPU5013__				DGS__YR			
		T	DGPT501334__	DGPT501301__	DGPT5013__				DGS__XR			DGC65013
		V	DGPV501334__	DGPV501301__	DGPV5013__				DGS__YL			
	25mm (1")	S	DGPS502534__	DGPS502501__	DGPS5025__		DGH55025__ DGH65025__		DGS__XL	DGC55025		
		U	DGPU502534__	DGPU502501__	DGPU5025__				DGS__YR			
		T	DGPT502534__	DGPT502501__	DGPT5025__				DGS__XR			DGC65025
		V	DGPV502534__	DGPV502501__	DGPV5025__				DGS__YL			
6mm (.236")	13mm (1/2")	S	DGPS601334__	DGPS601301__	DGPS6013__	'DGI6' (Page 6-1)	DGH56013__ DGH66013__		DGS__XL	DGC56013		
		U	DGPU601334__	DGPU601301__	DGPU6013__				DGS__YR			
		T	DGPT601334__	DGPT601301__	DGPT6013__				DGS__XR			DGC66013
		V	DGPV601334__	DGPV601301__	DGPV6013__				DGS__YL			
	25mm (1")	S	DGPS602534__	DGPS602501__	DGPS6025__		DGH56025__ DGH66025__		DGS__XL	DGC56025		
		U	DGPU602534__	DGPU602501__	DGPU6025__				DGS__YR			
		T	DGPT602534__	DGPT602501__	DGPT6025__				DGS__XR			DGC66025
		V	DGPV602534__	DGPV602501__	DGPV6025__				DGS__YL			

**DEEPGROOVE[®]
ALTERNATE PKGS**

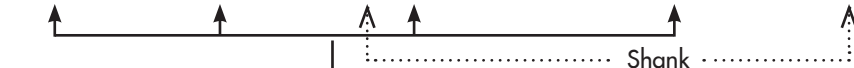

Major Diameter Range	Code
1.574"-1.968" (40-50mm)	45
1.968"-2.362" (50-60mm)	56
2.362"-2.952" (60-75mm)	67
2.952"-3.937" (75-100mm)	71
3.937"-5.905" (100-150mm)	11
5.905"-11.811" (150-300mm)	13
11.811"-∞ (300mm-∞)	30

Note:
As long as first plunge is made within major diameter range and each following plunge overlaps, groove width can be increased toward or away from center of part.

THINBIT[®]

DESIGN-A-GROOVE[®]

If you require a modification other than those detailed on the following pages, please call or submit your application print to our sales office.

<u>PAGE</u>	<u>MODIFICATION TYPE</u>
8-2	Face grooving
8-3	Definition of modifications
8-4	Modification specification sheet
8-5	Custom threads
8-6	Solid carbide custom blanks
8-7	Form tools

We are an industry leader at making custom tooling with competitive prices and fast delivery.

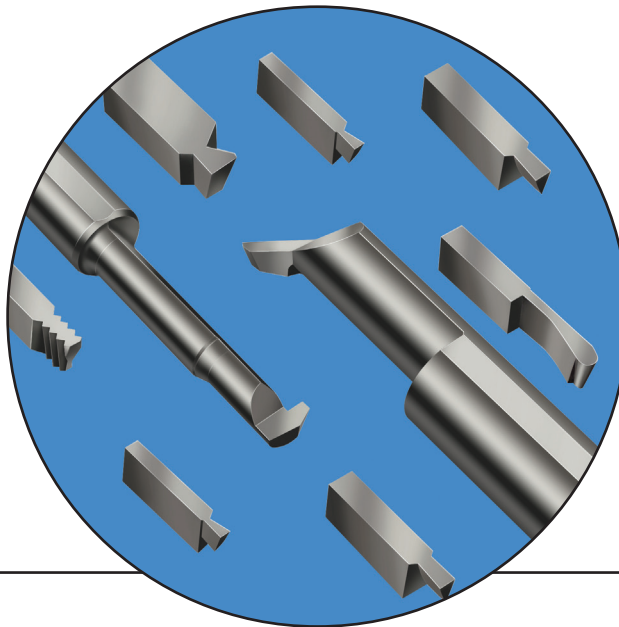

Our staff of sales associates and applications engineers process your quotes within 48 hours!

QUOTATION TO ORDER PROCESS

MODIFICATIONS

- Submit an application print or catalog sheet detailing your requirements. Include company name, contact name, email and telephone numbers. Submissions can be emailed to: **quotes@thinbit.com**.
- A quote will be returned within 48 hours which will include CAD drawings, price, delivery and payment terms.
- Review the quote information and CAD drawings. Fill in the 'Quote Summary Sheet' with item quantities and approval signatures.
- Email the 'Quote Summary Sheet' to our sales office.
- The order will be confirmed. The confirmation will summarize order and include delivery date.

KAISER TOOL COMPANY, INC.

Phone: 888-THINBIT (888-844-6248) or (260) 484-3620
 www.thinbit.com • Orders: orders@thinbit.com • Quotes: quotes@thinbit.com

PROVIDE THESE TOOLING SPECIFICATIONS

FACE GROOVE TYPE:

- Flat Face Shoulder Face
 Internal Angled

SPINDLE ROTATION: (Looking at spindle face)

- Clockwise Counter-Clockwise

WIDTH ('A'): _____
 (.004" minimum suggested)

DEPTH OF CUT ('B'): _____
 (as required)

MAJOR DIAMETER ('C'): _____
 (.200" minimum suggested)

DEPTH INTO BORE ('D'): _____
 (as required)

ANGLE ('E'): _____
 (as required)

MATERIAL BEING MACHINED: _____

COATING OPTIONS:

- TiN TiCN
 TiAlN Diamond

TOOLHOLDER OPTIONS:

- Square Straight Right Hand Shank
 Round 90° Left Hand Size: _____

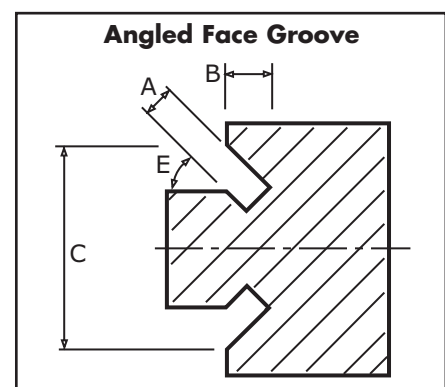
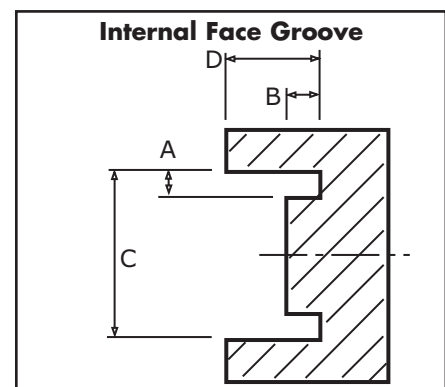
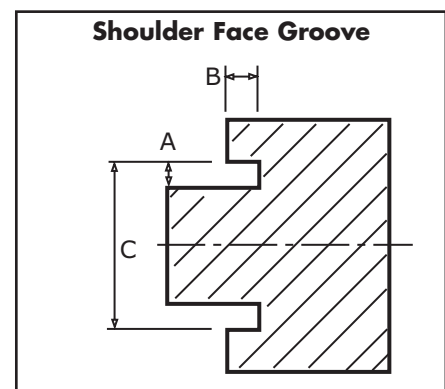
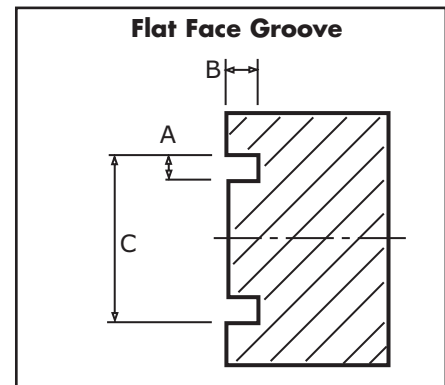

Submitting this form will generate a quote within 48 hours which will include price, delivery and CAD drawing(s) for your review and approval. If possible, please include an application print or sketch.

Return quote to:

Name: _____

Company: _____

Address: _____

Phone: (____) - _____ - _____

Email Address: _____

MODIFICATIONS

KAISER TOOL COMPANY, INC.

Phone: 888-THINBIT (888-844-6248) or (260) 484-3620
 www.thinbit.com • Orders: orders@thinbit.com • Quotes: quotes@thinbit.com

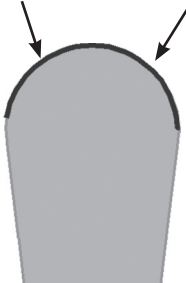
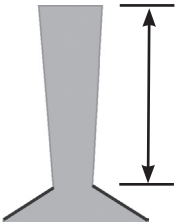
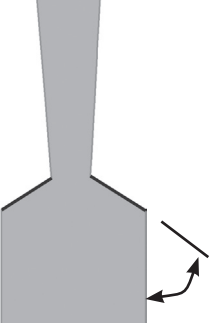
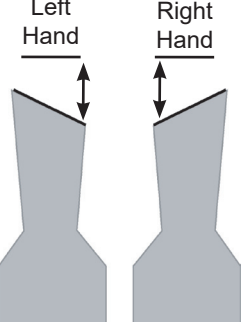
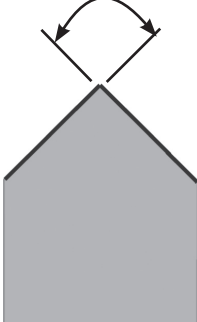
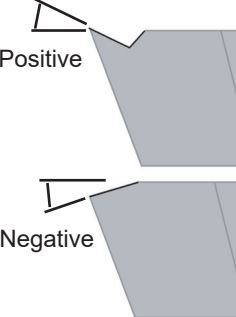
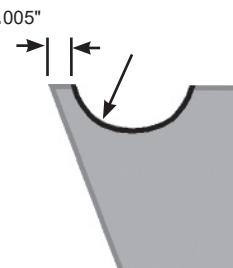
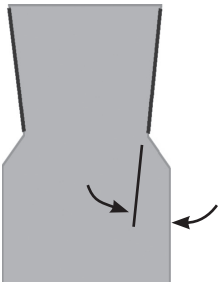
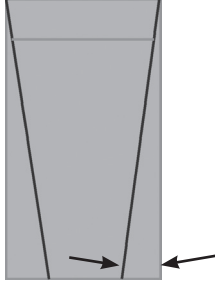
 <p>SIZING Looking at the top of the insert, sizing is the width of the cutting edge.</p>	 <p>RADIUS Looking at the top of the insert, the radii are the rounded corners of the cutting edge. A full radius means each radius is one half the width of the insert.</p>
 <p>DEPTH OF CUT Looking at the top of the insert, depth of cut is the depth the insert will cut into part before edge(s) drag.</p>	 <p>CHAMFER Looking at the top of the insert, chamfer is a secondary cutting edge. Standard angle is 45°.</p>
 <p>LEAD ANGLE Looking at the top of the insert, lead angle is the angle along the cutting edge of the insert.</p>	 <p>INCLUDED ANGLE Looking at the top of the insert, the included angle is the angle between the cutting edges.</p>
 <p>TOP RAKE Looking at the side of the insert, top rake is the angle between the top of the insert and the cutting edge.</p>	 <p>CHIPBREAKER Looking at the side of the insert, a chipbreaker is a 1/32" radius ground .005" back from the cutting edge.</p>
 <p>BACK CLEARANCE Looking at the top of the insert, back clearance is the angle behind the cutting edge.</p>	 <p>SIDE CLEARANCE Looking at the front of the insert, side clearance is the angle from the top of the insert to the bottom of the insert.</p>

KAISER TOOL COMPANY, INC.

Phone: 888-THINBIT (888-844-6248) or (260) 484-3620
www.thinbit.com • Orders: orders@thinbit.com • Quotes: quotes@thinbit.com

BASE TOOL:

MATERIAL BEING MACHINED:

COATING OPTIONS: (Select 1 only)

- TiN TiCN
 TiAlN Diamond

TOOLHOLDER OPTIONS: Size _____

- Square Straight Right Hand
 Round 90° Left Hand

SPINDLE ROTATION (Looking at spindle face)

- Clockwise Counter-Clockwise

SKETCH AREA

Submitting this form will generate a quote within 48 hours which will include price, delivery and CAD drawing(s) for your review and approval. If possible, please include an application print or sketch.

Return quote to:

Name: _____

Company: _____

Address: _____

Phone: (____) - ____ - _____

Email Address: _____

	Left Hand Side Geometry	Right Hand Side Geometry
	_____ Insert Width in .xxx" _____ Tolerance in +.xxx"/-.xxx" (± .001" standard)	
	<input type="checkbox"/> Full Radius	
	_____ Corner Radius in .xxx" _____ Tolerance in +.xxx"/-.xxx" (± .002" standard)	_____ Corner Radius in .xxx" _____ Tolerance in +.xxx"/-.xxx" (± .002" standard)
	_____ Total Depth of Cut in .xxx"	_____ Total Depth of Cut in .xxx"
	_____ Chamfer Angle in x° _____ Total Depth of Chamfer required in .xxx" _____ Tolerance in +.xxx"/-.xxx" (± .001" standard)	_____ Chamfer Angle in x° _____ Total Depth of Chamfer required in .xxx" _____ Tolerance in +.xxx"/-.xxx" (± .001" standard)
	_____ Lead Angle in x° _____ Tolerance in +x°/-x° (± .5° standard)	_____ Lead Angle in x° _____ Tolerance in +x°/-x° (± .5° standard)
	_____ Included Angle in x° _____ Tolerance in +x°/-x° (± .5° standard)	
	_____ Top Rake Angle in x° <input type="checkbox"/> Positive <input type="checkbox"/> Negative _____ Tolerance in +x°/-x° (± .5° standard)	
	<input type="checkbox"/> 1/32" Radius Chipbreaker with .005" land	
	_____ Back Clearance in x° _____ Tolerance in +x°/-x° (± .5° standard)	_____ Back Clearance in x° _____ Tolerance in +x°/-x° (± .5° standard)
	_____ Side Clearance in x° _____ Tolerance in +x°/-x° (± .5° standard)	_____ Side Clearance in x° _____ Tolerance in +x°/-x° (± .5° standard)

SPEC SHEET MODIFICATIONS

KAISER TOOL COMPANY, INC.

Phone: 888-THINBIT (888-844-6248) or (260) 484-3620
 www.thinbit.com • Orders: orders@thinbit.com • Quotes: quotes@thinbit.com

PROVIDE THESE TOOLING SPECIFICATIONS

THREAD TYPE:

- EXTERNAL
 INTERNAL BORE DIAMETER: _____

REACH INTO BORE: _____

ORIENTATION:

- RIGHT HAND LEFT HAND

FEED DIRECTION:

- Toward Spindle Away from Spindle

ANSI THREAD FORM: _____

THREAD FORM: _____

(Acme, Buttress, Square, etc.)

THREADS PER INCH: _____

NUMBER OF STARTS: _____

MAJOR DIAMETER: _____

(Largest diameter of thread)

MINOR DIAMETER: _____

(Smallest diameter of thread)

MATERIAL BEING MACHINED: _____

COATING OPTIONS:

- TiN TiCN
 TiAlN DIAMOND

TOOLHOLDER OPTIONS:

- Square Straight Right Hand
 Round 90° Left Hand

SHANK SIZE: _____

SKETCH AREA

Submitting this form will generate a quote within 48 hours which will include price, delivery and CAD drawing(s) for your review and approval. If possible, please include an application print or sketch.

Return quote to:

Name: _____

Company: _____

Address: _____

Phone: (____) - _____ - _____

Email Address: _____

KAISER TOOL COMPANY, INC.

Phone: 888-THINBIT (888-844-6248) or (260) 484-3620
 www.thinbit.com • Orders: orders@thinbit.com • Quotes: quotes@thinbit.com

MICROBIT[®] CUSTOM BLANKS

PROVIDE THESE TOOLING SPECIFICATIONS

TOOL TYPE:

- Grooving Face Grooving
 Boring Threading

ORIENTATION:

- Right Hand Left Hand

WIDTH ('A'): _____
 (.004" minimum)

SHANK DIAMETER ('B'): _____
 (1/8", 3/16", 1/4", 5/16", 3/8", 1/2")

MINIMUM

BORE DIAMETER ('C'): _____
 (.073" minimum suggested)

OVERALL LENGTH ('D'): _____
 (.875" minimum, 4" maximum suggested;
 stock lengths may be substituted)

REACH ('E'): _____
 (.250" minimum, 4 times 'B' maximum suggested)

PROJECTION ('F'): _____
 (3 times 'A' maximum suggested;
 for threading tool, specify threads per inch)

MATERIAL BEING MACHINED: _____

COATING OPTIONS:

- TiN TiCN
 TiAlN DIAMOND

Submitting this form will generate a quote within 48 hours which will include price, delivery and CAD drawing(s) for your review and approval. If possible, please include an application print or sketch.

Return quote to:

Name: _____

Company: _____

Address: _____

Phone: (____) - ____ - _____

Email Address: _____

Grooving Tool Geometry

Right hand shown. See Page 1-4 for standard cutting geometry.

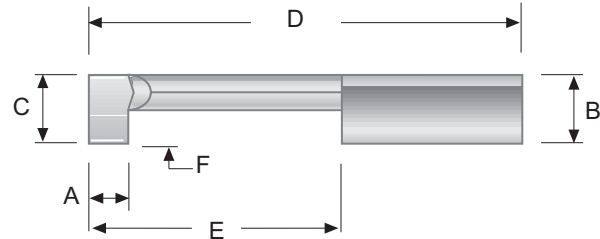

Face Grooving Tool Geometry

Clockwise shown. See Page 2-4 for standard cutting geometry.

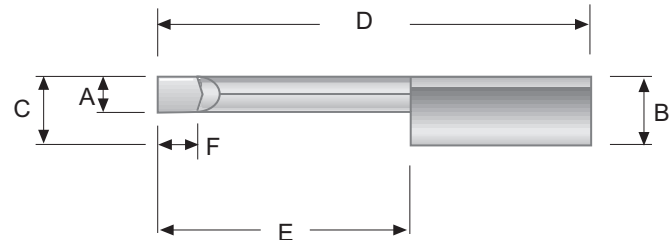

Boring Tool Geometry

Right hand shown. See Page 3-4 for standard cutting geometry.

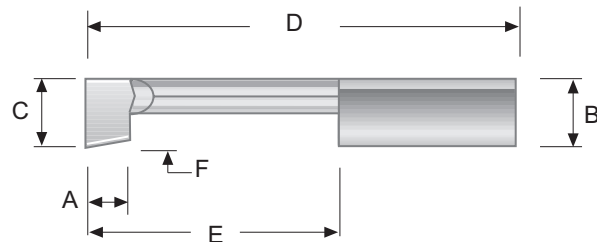

Threading Tool Geometry

Right hand shown. See Page 4-4 & 4-6 for standard cutting geometry.

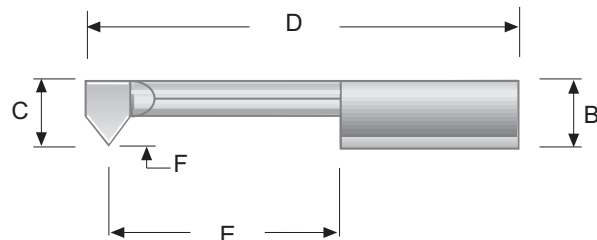

CUSTOM BLANKS MODIFICATIONS

KAISER TOOL COMPANY, INC.

Phone: 888-THINBIT (888-844-6248) or (260) 484-3620
 www.thinbit.com • Orders: orders@thinbit.com • Quotes: quotes@thinbit.com

THINBIT®

FORM-A-GROOVE®

FORM-A-GROOVE® tools can consist of combinations of simple grooves or more complex combinations of grooves, arcs, angles, convex and concave radii, as well as special thread forms.

FORM-A-GROOVE® tools can simplify programming, increase production and free tool locations for other tools.

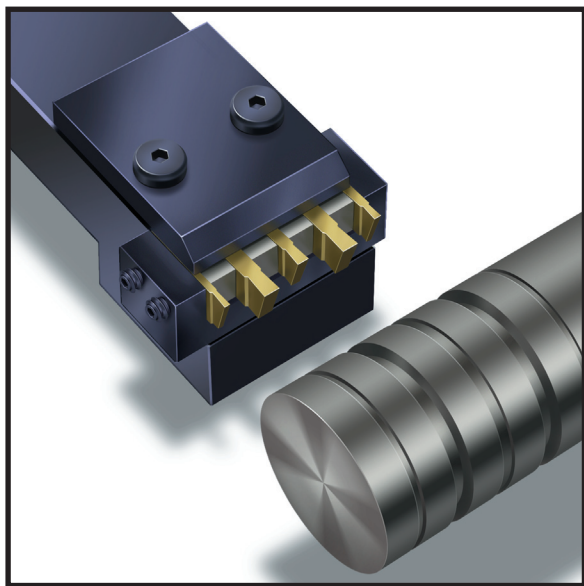

External and Face applications

- Up to 2" wide
- Made from stacking individual inserts or from a solid block of carbide

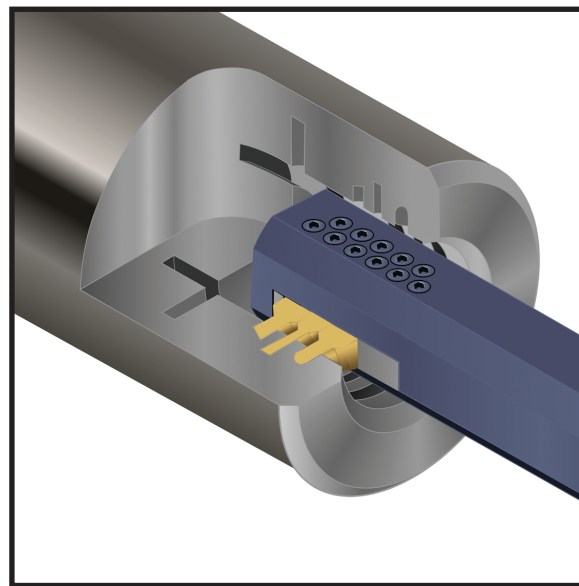

Internal applications

- Up to 1" wide
- Starting at .125" minimum bore

QUOTATION TO ORDER PROCESS

- Submit an application print detailing your requirements. Include company name, contact name, email, and telephone numbers. If possible, please include an application print or sketch. Submissions can be emailed to: quotes@thinbit.com.
- A quote will be returned within 48 hours which will include CAD drawings, price, delivery and payment terms.
- Review the quote information and CAD drawings. Fill in the 'Quote Summary Sheet' with item quantities and approval signatures.
- Email the 'Quote Summary Sheet' to our sales office.
- The order will be confirmed. The confirmation will summarize order and include delivery date.

If you require a modification other than those detailed on this page, please call or submit your application print to our sales office.

KAISER TOOL COMPANY, INC.

Phone: 888-THINBIT (888-844-6248) or (260) 484-3620
www.thinbit.com • Orders: orders@thinbit.com • Quotes: quotes@thinbit.com

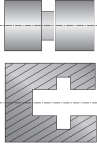
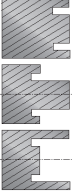
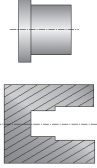
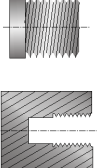
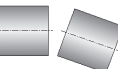
	<p style="text-align: center;">GENERAL TECHNICAL INFORMATION</p> <p>PAGE 9-2 PAGE OMITTED PAGE 9-3 EXTERNAL APPLICATION REFERENCE PAGE 9-4 INTERNAL APPLICATION REFERENCE PAGE 9-5 INSERT GRADE INFORMATION PAGE 9-6 INSERT COATING INFORMATION PAGE 9-7 TROUBLESHOOTING INFORMATION PAGE 9-8 GENERAL TOOLHOLDER INFORMATION</p>
	<p style="text-align: center;">GROOVING - CATALOG SECTION 1</p> <p>PAGE 9-9 GEOMETRY AND SET-UP INFORMATION PAGE 9-10 SPEEDS AND FEEDS</p>
	<p style="text-align: center;">FACE GROOVING - CATALOG SECTION 2</p> <p>PAGE 9-11 GEOMETRY AND SET-UP INFORMATION PAGE 9-12 SPEEDS AND FEEDS</p>
	<p style="text-align: center;">BORING & TURNING - CATALOG SECTION 3</p> <p>PAGE 9-13 GEOMETRY AND SET-UP INFORMATION PAGE 9-14 SPEEDS AND FEEDS FOR MBE, MBF AND MBG SERIES BORING BARS PAGE 9-15 SPEEDS AND FEEDS FOR MBZ, MBA, MBB AND MBC SERIES BORING BARS AND MICROBIT® SOLID CARBIDE BORING TOOLS PAGE 9-16 SPEEDS AND FEEDS FOR MBA, MBB AND MBC PCD AND CBN TIPPED INSERTS</p>
	<p style="text-align: center;">THREADING - CATALOG SECTION 4</p> <p>PAGE 9-17 GEOMETRY AND SET-UP INFORMATION PAGE 9-18 SPEEDS AND FEEDS</p>
	<p style="text-align: center;">PARTING - CATALOG SECTION 5</p> <p>PAGE 9-19 GEOMETRY AND SET-UP INFORMATION PAGE 9-20 SPEEDS AND FEEDS</p>

HOURS:

OUR BUSINESS HOURS ARE:
 MONDAY - THURSDAY **7:30AM** TO **5:00PM** EASTERN STANDARD TIME.
 PROCESSING FOR SAME DAY SHIPMENT STOPS AT **3:00PM** EASTERN STANDARD TIME.
 FRIDAY **7:30AM** TO **2:00PM** EASTERN STANDARD TIME.
 PROCESSING FOR SAME DAY SHIPMENT STOPS AT **12:00PM** EASTERN STANDARD TIME.

LOT NUMBERS: MOST PRODUCTS HAVE A 6 DIGIT LOT NUMBER LASER ENGRAVED ALONG WITH THE PART NUMBER. THIS NUMBER MAY REQUIRE 10X MAGNIFICATION TO READ.

NOTE: REGISTERED PATENTS AND TRADEMARKS LICENSED TO KAISER TOOL COMPANY, INC. ARE LOCATED ON OUR WEBSITE AT: [HTTP://WWW.THINBIT.COM/ABOUT/TRADE_NAMES.HTML](http://www.thinbit.com/about/trade_names.html)

KAISER TOOL COMPANY, INC.

Phone: 888-THINBIT (888-844-6248) or (260) 484-3620
www.thinbit.com • Orders: orders@thinbit.com • Quotes: quotes@thinbit.com



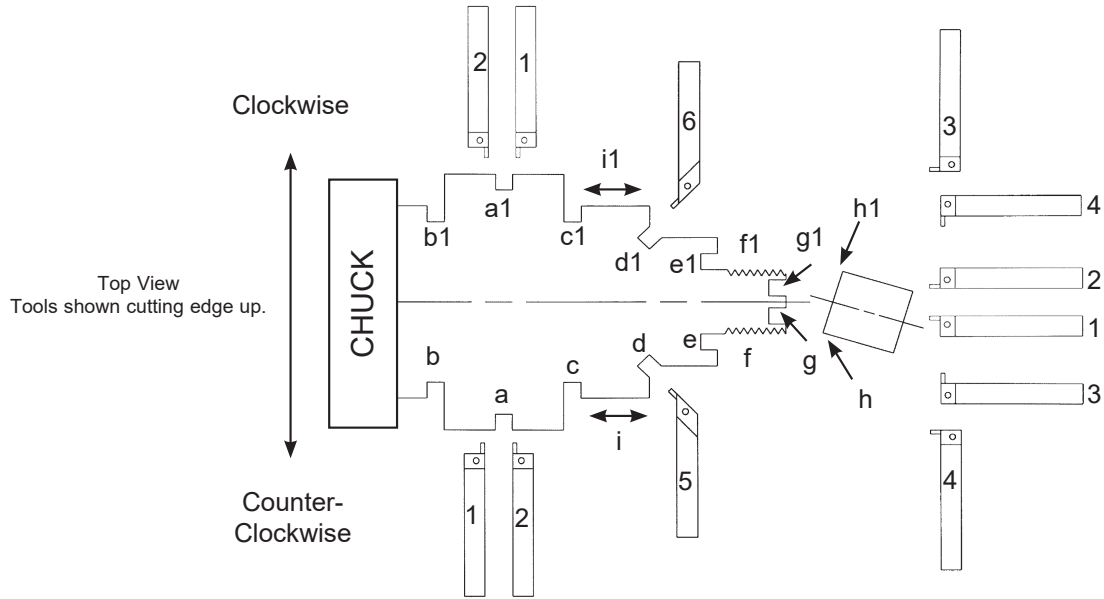

External Application Reference						
Description	Specification	Operation	Insert Orientation	Insert Page	Toolholder Compatibility	Toolholder Page
OD Groove Reference: a,a1	.004" - .150" insert widths in .001" increments; Depths of cut 2.5 to 3 times width; For grooving, turning and generating profiles; Carbide and High Speed Steel.	a	Right Hand	1-10	2,3	7-1
		a1	Left Hand	1-10	1,4	7-1
	2,3,4,5 & 6mm insert widths; Depths of cut .5" to 1".	a	---	6-2	2,3	1-11
		a1	---	6-2	1,4	1-11
OD Groove at a shoulder Reference: b,b1,c,c1	.004" - .150" insert widths in .001" increments; Depths of cut 2.5 to 3 times width; For grooving, turning and generating profiles; Carbide and High Speed Steel.	b & c1	Left Hand	1-10	1,4	7-1
		b1 & c	Right Hand	1-10	2,3	7-1
	2,3,4,5 & 6mm insert widths; Depths of cut .5" to 1".	b & c1	---	6-2	1,4	1-11
		b1 & c	---	6-2	2,3	1-11
30°/45°/60° Undercut Reference: d,d1	.004" - .150" insert widths in .001" increments; Depths of cut 2.5 to 3 times width; .300", .750", 1.250" & 3" major diameters.	d	Counter-Clockwise	2-10	5	7-11, 7-15 & 7-16
		d1	Clockwise	2-10	6	7-11, 7-15 & 7-16
Face Groove Reference: e,e1,g,g1	.004" - .150" insert widths in .001" increments; Depths of cut 2.5 to 3 times width; For grooving, turning and generating profiles; Carbide and High Speed Steel.	e & g	Counter-Clockwise	2-10	1,4	7-1
		e1 & g1	Clockwise	2-10	2,3	7-1
	2,3,4,5 & 6mm insert widths; Depths of cut .5" to 1".	e & g	---	6-2	1,4	2-11
		e1 & g1	---	6-2	2,3	2-11
Threading Reference: f,f1	8 Threads Per Inch and greater Carbide and High Speed Steel.	f	Right Hand	4-10	2,3	7-1
		f1	Left Hand	4-10	1,4	7-1
	Acme threading 4 Threads Per Inch and greater Carbide and High Speed Steel.	f & f1	Right Hand	4-12	2,3	7-1
Parting Reference: h,h1	.025", .045", .062", .085" & .115" insert widths; Depths of cut .200" and .500"; Carbide and High Speed Steel.	h	---	5-4	2,3	7-1
		h1	---	5-4	1,4	7-1
Turning Reference: i,i1	TD and TP style inserts.	i	---	3-16,3-18	2,3	3-20
		i1	---	3-16,3-18	1,4	3-20

KAISER TOOL COMPANY, INC.

Phone: 888-THINBIT (888-844-6248) or (260) 484-3620
 www.thinbit.com • Orders: orders@thinbit.com • Quotes: quotes@thinbit.com

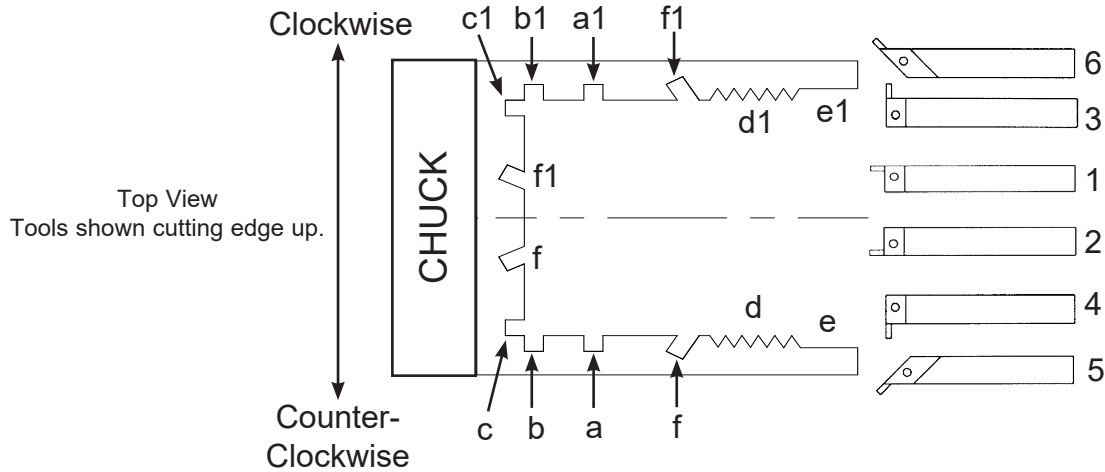

Internal Application Reference						
Description	Specification	Operation	Insert Orientation	Insert Page	Toolholder Compatibility	Toolholder Page
Groove Reference: a,a1,b,b1	For internal diameters .125" and larger; .004" - .250" insert widths in .001" increments; Depths of cut to .150"; 1/8", 3/16", 1/4", 5/16", 1/2" solid carbide shanks.	a,b	Right Hand	1-4	---	7-2
		a1 & b1	Left Hand	1-4	---	7-2
	For internal diameters .325" and larger; .004" - .125" insert widths in .001" increments; Depths of cut to .125"; For grooving, boring and generating profiles.	a & b	Left Hand	2-5	4	1-6
	For internal diameters 1" and larger; 2,3 & 4mm insert widths; Depths of cut .5".	a & b1	Right Hand	2-5	3	1-6
	For internal diameters 1.250" and larger; .004" - .150" insert widths in .001" increments; Depths of cut 2.5 to 3 times width; For grooving, turning and generating profiles; Carbide and High Speed Steel.	a & b	Left Hand	1-10	4	7-8
		a1 & b1	Right Hand	1-10	3	7-8
Face Groove Reference: c,c1	For internal diameters .125" and larger; .004" - .250" insert widths in .001" increments; Depths of cut to .150"; 1/8", 3/16", 1/4", 5/16", 1/2" solid carbide shanks.	c	Right Hand	2-4	---	7-2
		c1	Left Hand	2-4	---	7-2
	.004" - .150" insert widths in .001" increments; Depths of cut 2.5 to 3 times width; For grooving, turning and generating profiles; Carbide and High Speed Steel.	c	Counter-Clockwise	2-10	1,4	7-1
	For internal diameters .415" and larger; .004" - .125" insert widths in .001" increments; Depths of cut to .125"; For grooving, boring and generating profiles.	c	Right Hand	2-5	2	2-6
		c1	Left Hand	2-5	1	2-6
	For internal diameters 1.574" and larger; 2,3,4,5 & 6mm insert widths; Depths of cut .5" to 1".	c	---	6-2	2	2-8
		c1	---	6-2	1	2-8
Threading Reference: d,d1	For internal diameters .077" and larger; 4 Threads per Inch and greater; 1/8", 3/16", 1/4", 5/16", 1/2" solid carbide shanks.	d	Right Hand	4-4	---	7-2
		d1	Left Hand	4-4	---	7-2
	For internal Acme diameters .187" and larger 6 Threads per Inch and greater 3/16", 1/4", 5/16", 3/8" solid carbide shanks.	d	Right Hand	4-6	---	7-2
		d1	Left Hand	4-6	---	7-2
	For internal diameters .325" and larger; 9 Threads per Inch and greater.	d	Left Hand	4-8	4	1-6
		d1	Right Hand	4-8	3	1-6
	For internal diameters 1.250" and larger; 8 Threads per Inch and greater; Carbide and High Speed Steel.	d	Right Hand	4-10	4	7-8
	d1	Left Hand	4-10	3	7-8	
	For internal Acme threading 1.250" and larger 4 Threads per Inch and greater Carbide and High Speed Steel.	d & d1	Right Hand	4-12	3,4	7-1
Boring Reference: e,e1	For internal diameters .073" and larger; 1/8", 3/16", 1/4", 5/16", 1/2" solid carbide shanks.	e	Right Hand	3-4	---	7-2
		e1	Left Hand	3-4	---	7-2
	For internal diameters .165" and larger; WCGT, CD, TD and TP style inserts.	e	---	3-1	4	3-1
		e1	---	3-1	3	3-1
30/45/60 Undercut f, f1	Minimum bore requirements: 45° is 1.125, Left Hand 30° and Right Hand 60° is 1.170; Left Hand 60° and Right Hand 30° require custom inserts. Shank Diameters in 1/2", 5/8", 3/4", 1", 20mm and 25mm	f	Right Hand	2-10	5	7-14
		f1	Left Hand	2-10	6	7-14

KAISER TOOL COMPANY, INC.

Phone: 888-THINBIT (888-844-6248) or (260) 484-3620
www.thinbit.com • Orders: orders@thinbit.com • Quotes: quotes@thinbit.com

DURA-MAX® 2000 CARBIDE

DURA-MAX® 2000 is a versatile and tough sub-micron grain carbide. Because of its high transverse rupture strength and fine grain structure, **DURA-MAX® 2000** performs well with interrupted cuts. This grade is recommended for cutting steel, cast iron, stainless steel and applications where there are interrupted cuts.

DURA-MAX® 2000 approximates an ANSI C4/C5.

DURA-MAX® 3000 CARBIDE

DURA-MAX® 3000 is a hard and wear resistant sub-micron grain carbide. **DURA-MAX® 3000** is designed for light finish cuts. This grade is recommended for cutting steels and applications where precision finish cuts are required.

DURA-MAX® 3000 approximates an ANSI C7/C8.

DURA-MAX® 3000 inserts are only available on MINI-BORE® style inserts. See Section 3 of this catalog for further detail.

DURA-MAX® 4000 CARBIDE

DURA-MAX® 4000 is a tough, general purpose sub-micron grain carbide. **DURA-MAX® 4000** is designed for roughing. This grade is recommended for cutting steels, stainless steel, nickel based alloys and applications where there are interrupted cuts.

DURA-MAX® 4000 approximates an ANSI C5/C6.

DURA-MAX® 4000 inserts are only available on MINI-BORE® style inserts. See Section 3 of this catalog for further detail.

DURA-MAX® 5000 CARBIDE

DURA-MAX® 5000 is a hard, abrasion resistant, sub-micron grain carbide. Because of its hardness and fine grain structure, **DURA-MAX® 5000** provides excellent edge and corner retention. This grade is recommended for cutting abrasive materials, non-ferrous alloys, aluminum, plastic and applications where there are no interrupted cuts.

DURA-MAX® 5000 approximates an ANSI C2/C3.

DURA-MAX® 8000 CBN

DURA-MAX® 8000 is a **CBN** tipped insert which provides an increased production rate, improved surface finish and dimensional control when used on high-temperature alloys such as inconel, nickel base alloys and materials with a hardness of Rockwell C-35 or harder.

DURA-MAX® 8000 CBN tipped inserts are only available on MINI-BORE® style inserts. See Section 3 of this catalog for further detail.

DURA-MAX® 9000 PCD

DURA-MAX® 9000 is a **PCD** tipped insert which provides an increased production rate, improved surface finish and dimensional control when used on non-ferrous and abrasive metals such as aluminum, brass and copper.

DURA-MAX® 9000 PCD tipped inserts are only available on MINI-BORE® style inserts. See Section 3 of this catalog for further detail.

HIGH SPEED STEEL

High Speed Steel will cut most materials. It will take considerable abuse. However, high speed steel will not wear as well as carbide. We suggest the use of high speed steel for jobs of 500 cuts or less. It also works well on older machines which do not have high enough spindle speeds to take advantage of carbide.

High Speed Steel is an M42 grade.

KAISER TOOL COMPANY, INC.

Phone: 888-THINBIT (888-844-6248) or (260) 484-3620
www.thinbit.com • Orders: orders@thinbit.com • Quotes: quotes@thinbit.com

<p>TiN (TITANIUM NITRIDE)</p>	<p>Excellent general purpose PVD coating for most applications. TiN offers excellent wear resistance and allows 10% - 30% increase in speeds and feeds. TiN also increases lubricity at cutting edge which reduces galling and welding. TiN is not recommended for Nickel alloys or Titanium.</p> <p>Color: Yellow/gold</p> <p>Thickness: 2-4 microns (.0001"-.0002")</p>
<p>TiCN (TITANIUM CARBONITRIDE)</p>	<p>A multi-layer, PVD coating good for cutting Aluminum, Brass, Bronze, Copper and its alloys and Cast Iron. TiCN improves tool life and allows increased speeds and feeds. Should out-perform TiN in abrasive and difficult to machine materials. TiCN is harder and more impact resistant than TiN.</p> <p>Color: Gray/bronze</p> <p>Thickness: 2-6 microns (.0001"-.0004")</p>
<p>TiAlN (TITANIUM ALUMINUM NITRIDE)</p>	<p>A high performance PVD coating which excels in cutting abrasive or difficult-to-machine materials such as Titanium, Inconel, Waspaloy, Hastelloy, High Nickel Alloys, harder varieties of Stainless Steel. Good performance with interrupted cuts, high temperatures and dry machining.</p> <p>Color: Dark gray/black</p> <p>Thickness: 2-4 microns (.0001"-.0002")</p>
<p>DIAMOND</p>	<p>Works well in cutting Aircraft Aluminum, Automotive Cast Aluminum, Copper, Brass, Graphite, Carbon, Various Plastics, Nylon, Natural Wood, Composite Woods and Kurtzite. Diamond coating is not recommended for cutting steels or other ferrous metals.</p> <p>Color: Silver</p> <p>Thickness: 2-6 microns (.0001"-.0004")</p> <p>May require a 5 piece minimum order.</p>

Note on coolants:

THINBIT® inserts are compatible with all coolant types. Carbide and High Speed Steel give best performance on most materials when run flooded with coolant. Carbide does not perform well in thermal shock situations. Keep insert flooded or run dry.

Note on coatings:

Part numbers may not always include coating designation.

KAISER TOOL COMPANY, INC.

Phone: 888-THINBIT (888-844-6248) or (260) 484-3620
 www.thinbit.com • Orders: orders@thinbit.com • Quotes: quotes@thinbit.com

It is critical for small tooling to have correct set ups. Speeds and feeds, condition of toolholder, insert and machine, centerline heights, squareness of cutting edge to machine, rigid machine to toolholder relationships are vital for proper performance in all applications. The items listed are general guides, but will not solve all problems. Please call our sales office for additional assistance.

Problem	Things to try
Grooving	
Cutting oversized; Groove walls not square	Check insert squareness; Check toolholder condition; Check insert centerline; Check machine alignment; Decrease IPR
Chatter; Poor finish	Increase speed; Reduce feed; Check toolholder condition; Check centerline; Stub toolholder and review toolholder size and machine set up for maximum rigidity; Add coating; Add top rake
Built up edge; Insert chipping	Increase feed; Increase speed; Run with coolant; Use coated insert; Check insert centerline
Burr on part	Add chamfer to insert; Turn or bore diameter after groove
Insert breaking	Check insert squareness; Check toolholder condition; Check insert centerline; Check machine condition; Decrease IPR; Review speeds and feeds; Verify insert grade
Chip control	Increase feed; Use peck cycle; Mount with cutting edge down; Flood with coolant; Add chip control to insert
Face Grooving	
Cutting oversized; Groove walls not square	Check insert squareness; Check toolholder condition; Check insert centerline; Check machine alignment; Decrease IPR
Chatter; Poor finish	Increase speed; Reduce feed; Check toolholder condition; Check centerline; Stub toolholder and review toolholder size and machine set up for maximum rigidity; Add coating; Add top rake
Built up edge; Insert chipping	Increase feed; Increase speed; Run with coolant; Use coated insert; Check insert centerline
Burr on part	Add chamfer to insert; Turn or bore diameter after groove
Insert breaking	Check insert squareness; Verify clearance diameter; Check insert centerline; Check toolholder condition; Check machine condition; Decrease IPR; Review speeds and feeds; Verify insert grade
Chip control	Increase feed; Use peck cycle; Mount with cutting edge down; Flood with coolant; Add chip control to insert
Boring/Turning	
Chatter; Poor Finish	Increase speed; Reduce feed; Check toolholder condition; Check centerline; Verify chip evacuation; Verify coolant reaching cutting edge; Stub toolholder and review toolholder size and machine set up for maximum rigidity; Add coating; Add top rake
Built up edge; Insert chipping	Increase feed; Increase speed; Increase corner radius; Run with coolant; Use coated insert; Check insert centerline
Insert breaking	Check squareness; Verify clearance diameter; Check centerline; Check toolholder condition; Check machine condition; Decrease IPR; Review speeds and feeds; Verify insert grade
Chip control	Increase feed; Mount with cutting edge down; Flood with coolant; Add chip control to insert
Threading	
Chatter; Poor finish	Increase speed; Reduce depth of cut per pass; Check toolholder condition; Check centerline; Verify chip evacuation; Verify coolant reaching cutting edge; Stub toolholder and review toolholder size and machine set up for maximum rigidity; Add coating
Built up edge; Insert chipping	Increase depth of cut per pass; Increase speed; Increase corner radius; Run with coolant; Use coated insert; Check insert centerline
Insert breaking	Check squareness; Check centerline; Check toolholder condition; Check machine condition; Decrease depth of cut per pass; Review speeds and feeds; Verify insert grade
Parting	
Insert leading; Faces not square	Check insert squareness; Check toolholder condition; Check insert centerline; Check machine alignment; Decrease IPR; Add lead angle
Chatter; Poor finish	Increase speed; Reduce feed; Check toolholder condition; Check centerline; Stub toolholder and review toolholder size and machine set up for maximum rigidity; Add coating; Add top rake
Built up edge; Insert chipping	Increase feed; Increase speed; Run with coolant; Use coated insert; Check insert centerline
Burr on part	Chamfer before parting; Add lead angle to drop side of insert
Insert breaking	Check insert squareness; Check toolholder condition; Check insert centerline; Check machine condition; Decrease IPR; Review speeds and feeds; Verify insert grade
Chip control	Increase feed; Use peck cycle; Mount with cutting edge down; Flood with coolant; Add chip control to insert

KAISER TOOL COMPANY, INC.

Phone: 888-THINBIT (888-844-6248) or (260) 484-3620
 www.thinbit.com • Orders: orders@thinbit.com • Quotes: quotes@thinbit.com

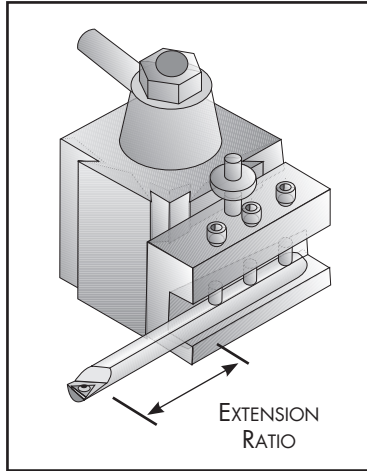

Extension Ratios						
Bar Diameter	Steel 4 x ø	Heavy Metal 6 x ø	Carbide 8 x ø	Shank Height	Steel	
.156"	.625"	.937"	1.250"	.312"	1.250"	
.187"	.750"	1.125"	1.500"	.375"	1.500"	
.250"	1.000"	1.500"	2.000"	.500"	2.000"	
.312"	1.250"	1.875"	2.500"	.625"	2.500"	
.375"	1.500"	2.250"	3.000"	.750"	2.500"	
.500"	2.000"	3.000"	4.000"	1.000"	2.500"	
.625"	2.500"	3.750"	5.000"	1.250"	2.500"	
.750"	3.000"					
1.000"	4.000"					

Extending a toolholder beyond these recommendations can cause excessive deflection which will result in poor surface finish and reduced insert life. These recommendations may need to be reduced if cutting materials with low machinability, taking heavy cuts or using the tooling in non-rigid machine set-ups.

Toolholder Notes:

- To avoid burrs on your shanks, use only dog point screws. The use of cup point screws promotes burrs on the shanks and can result in problems removing or re-installing bars.
- Complete toolholders may be an assembly of several components each having an individual part number.
- Heavy Metal is a high density Tungsten based alloy that is very tough, stiff and vibration resistant.

INTERNAL TOOL & FACE GROOVING CUTTING HEIGHTS	EXTERNAL TOOL CUTTING HEIGHTS
<ul style="list-style-type: none"> • Normal cutting forces cause tool deflection, therefore internal tools are manufactured to cut .002" to .010" above centerline. • Setting tool above 'A' will cause diameter to be under desired size. • Setting tool to cut at 'A' will cause insert to deflect to 'B' and cut desired diameter. • Setting tool below 'A' will cause insert to deflect to 'C' and cause diameter to be oversized. • Keep in mind if tools are mounted cutting edge toward floor, above center is toward floor. 	<ul style="list-style-type: none"> • External tools are manufactured to cut on center to .005" below centerline. • Setting tool to cut at 'A' can cause heel of insert to rub or cause failure. • Setting tool to cut at 'B' will cause insert to deflect slightly and cut at 'C'. • Setting tool below 'C' can cause insert to grab or fail. • Keep in mind if tools are mounted cutting edge toward floor, below center is toward ceiling.

DEEPGROOVE® Head and Shank Compatibility Chart														
Shank	Package	Page	Head	Clamp	Shank	Package	Page	Head	Clamp	Shank	Package	Page	Head	Clamp
DGS__XL	C	2-16	DGH4	DGC2	DGS__XR	B	2-16	DGH3	DGC1	DGS__ZR	N	2-8	DGH6	DGC6
	E	1-14	DGH2	DGC2		F	1-14	DGH1	DGC1		O	7-15	DGH3	DGC1
	S	7-16	DGH5	DGC5		T	7-16	DGH6	DGC6		Q	7-15	DGH1	DGC1
DGS__YR	D	2-16	DGH4	DGC2	DGS__YL	A	2-16	DGH3	DGC1	DGS__ZL	M	2-8	DGH5	DGC5
	G	1-14	DGH2	DGC2		H	1-14	DGH1	DGC1		P	7-15	DGH4	DGC2
	U	7-16	DGH5	DGC5		V	7-16	DGH6	DGC6		R	7-15	DGH2	DGC2

TROUBLE SHOOTING & TOOLHOLDERS

KAISER TOOL COMPANY, INC.

Phone: 888-THINBIT (888-844-6248) or (260) 484-3620
 www.thinbit.com • Orders: orders@thinbit.com • Quotes: quotes@thinbit.com

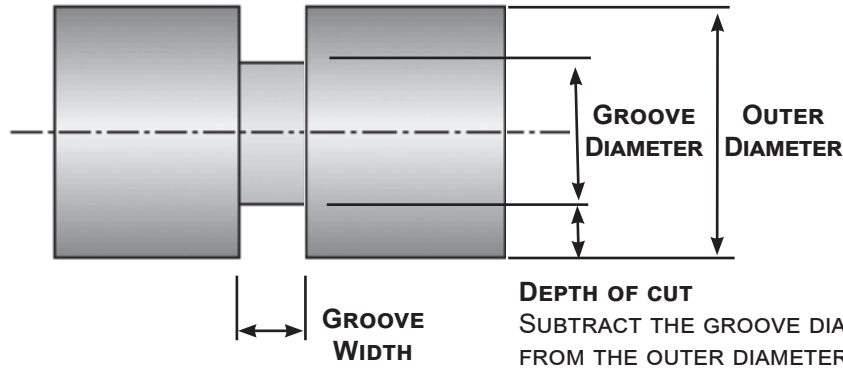

SUBTRACT THE GROOVE DIAMETER FROM THE OUTER DIAMETER AND DIVIDE BY 2.

Example: 1" outer diameter with .75" groove diameter.
 $\frac{1" - .75"}{2} = .125"$ depth of cut

Setup Guide

External Grooving Applications

Decrease surface speed (SFM)

Increase feed (IPR)

Set tool on center to .005" below center. Keep smaller inserts closer to center.

Modify Parameter

Insert width: .004" .020" .040" .060" .080" .100" .120" .140" .160" .180" .200" .220" .250"

Modify Parameter

Internal Grooving Applications

Decrease surface speed (SFM)

Increase feed (IPR)

Set tool .002" to .010" above center. Keep smaller inserts closer to center.

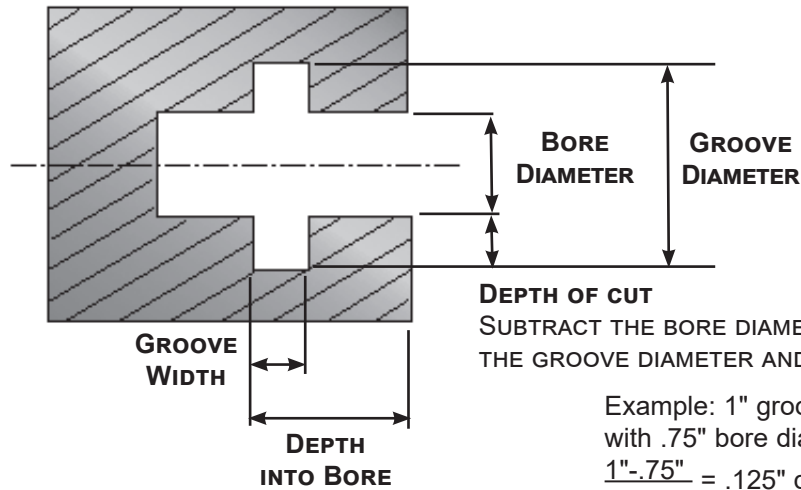

SUBTRACT THE BORE DIAMETER FROM THE GROOVE DIAMETER AND DIVIDE BY 2.

Example: 1" groove diameter with .75" bore diameter.
 $\frac{1" - .75"}{2} = .125"$ depth of cut

Insert begins with:
LGT, MGTI, GT

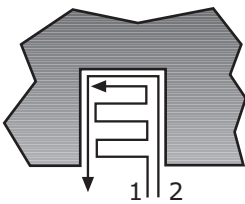

Insert begins with:
DGI, DGMI

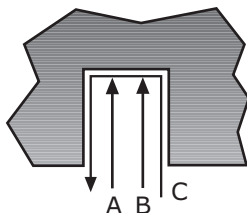

Cutting Paths

Use these diagrams for expanding the size of grooves.

Note: Side load on path 1 should be 10% to 30% of depth of cut on insert.

KAISER TOOL COMPANY, INC.

Phone: 888-THINBIT (888-844-6248) or (260) 484-3620

www.thinbit.com • Orders: orders@thinbit.com • Quotes: quotes@thinbit.com

Speeds & Feeds - Grooving						
Material To Be Cut		Carbide			High Speed Steel	
		Carbide Grade	Speed (SFM)	Feed (IPR)	Speed (SFM)	Feed (IPR)
Aluminum	2021-6061	DURA-MAX [®] 5000	1000	.002	500	.002
Brass		DURA-MAX [®] 5000	250	.001	75	.001
Bronze		DURA-MAX [®] 5000	250	.001	70	.001
Cast Iron	Gray	DURA-MAX [®] 5000	120-345	.0015-.004	35-125	.0015-.004
	Ductile	DURA-MAX [®] 2000	70-345	.001-.004	15-125	.001-.004
	Malleable	DURA-MAX [®] 2000	75-525	.0015-.003	35-170	.0015-.003
Copper	101-757	DURA-MAX [®] 5000	150-170	.002	85-90	.002
	834-978	DURA-MAX [®] 5000	600	.003	340	.003
Magnesium	AZ, AM, EZ, ZE, HK Types	DURA-MAX [®] 5000	1000	.002	500	.002
Nickel	Nickel 200-230	DURA-MAX [®] 5000	225	.002	85	.002
	Monel	DURA-MAX [®] 5000	150	.001-.0015	15-60	.001-.0015
	Inconel, Waspaloy	DURA-MAX [®] 5000	45	.002	15	.002
	Hastelloy	DURA-MAX [®] 5000	75-95	.002	10-15	.002
Plastic	Teflon (TFE, CTFE)	DURA-MAX [®] 5000	400	.002	250	.002
	Nylon	DURA-MAX [®] 5000	350-600	.002-.003	350	.002-.003
	Phenolic	DURA-MAX [®] 5000	600	.003	350	.003
	Glass Filled	DURA-MAX [®] 5000	250	.002	NA	NA
Stainless Steel	201-385	DURA-MAX [®] 5000	225-275	.001-.0015	65-85	.001-.0015
	405-446	DURA-MAX [®] 2000	300	.0011	90	.0011
	14-4, 15-5, 16-6, 17-4 PH	DURA-MAX [®] 2000	110-205	.0006-.0012	30-60	.0006-.0012
Steel	1005-1029	DURA-MAX [®] 2000	255-450	.001-.002	80-140	.001-.002
	1030-1055	DURA-MAX [®] 2000	115-370	.0009-.0015	35-115	.0009-.0015
	1060-1095	DURA-MAX [®] 2000	95-255	.0007-.001	30-80	.0007-.001
	10L45-10L50	DURA-MAX [®] 2000	130-450	.0009-.0015	40-140	.0009-.0015
	12L13-12L15	DURA-MAX [®] 2000	550-600	.003-.0035	225-280	.003-.0035
	41L30-41L50	DURA-MAX [®] 2000	65-350	.0007-.0015	20-110	.0007-.0015
	4140-4150	DURA-MAX [®] 2000	65-370	.0007-.0015	20-115	.0007-.0015
	4140 (35 HRc)	DURA-MAX [®] 2000	200	.001	70	.001
	8617-8622	DURA-MAX [®] 2000	125-390	.001-.0016	40-120	.001-.0016
	M1-M6	DURA-MAX [®] 2000	190	.0013	60	.0013
	H10-H19	DURA-MAX [®] 2000	65-255	.0007-.0011	20-80	.0007-.0011
	D2-D7	DURA-MAX [®] 2000	150-205	.001	45-60	.001
	A2-A9, 01-07	DURA-MAX [®] 2000	150-205	.001	45-60	.001
	W1, W2	DURA-MAX [®] 2000	375	.0015	110	.0015
	M-50, 52100	DURA-MAX [®] 2000	65-275	.0007-.0015	20-85	.0007-.0015
Titanium	Ti-6Al-6V	DURA-MAX [®] 5000	95	.001	45	.001

THESE SPEEDS AND FEEDS ARE GIVEN AS A STARTING POINT ONLY AND MAY BE ADJUSTED UP OR DOWN DEPENDING ON CONDITIONS. ANY TIME THERE IS AN INTERRUPTED CUT IN YOUR OPERATION, **DURA-MAX[®] 2000** CARBIDE IS RECOMMENDED.

FORMULA FOR CONVERSION FROM SFM TO RPM

SFM = SURFACE FEET PER MINUTE RPM = REVOLUTIONS PER MINUTE IPR = INCHES PER REVOLUTION DIAMETER = CUTTING DIAMETER π = 3.14

$$RPM = \frac{SFM \times 12}{(\pi) \times DIAMETER}$$

KAISER TOOL COMPANY, INC.

Phone: 888-THINBIT (888-844-6248) or (260) 484-3620
 www.thinbit.com • Orders: orders@thinbit.com • Quotes: quotes@thinbit.com

GROOVING

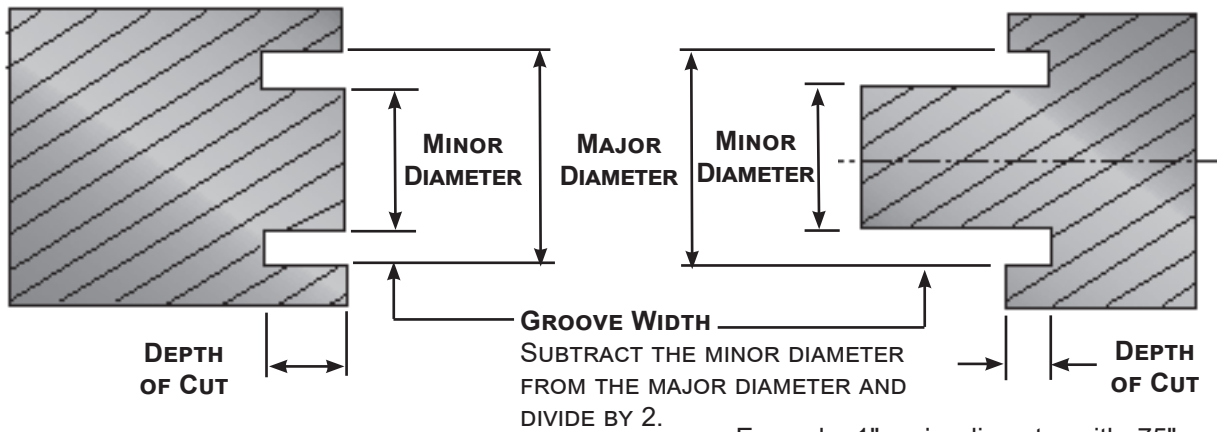

Example: 1" major diameter with .75" minor diameter.

$$\frac{1" - .75"}{2} = .125" \text{ Groove Width}$$

Setup Guide

External Face Grooving Applications

Decrease surface speed (SFM)

Increase feed (IPR)

Set tool on .002" to .010" above center. Keep smaller inserts closer to center.

Insert width:	.004"	.020"	.040"	.060"	.080"	.100"	.120"	.140"	.160"	.180"	.200"	.220"	.250"
	Modify Parameter												

Internal Face Grooving Applications

Decrease surface speed (SFM)

Increase feed (IPR)

Set tool .002" to .010" above center. Keep smaller inserts closer to center.

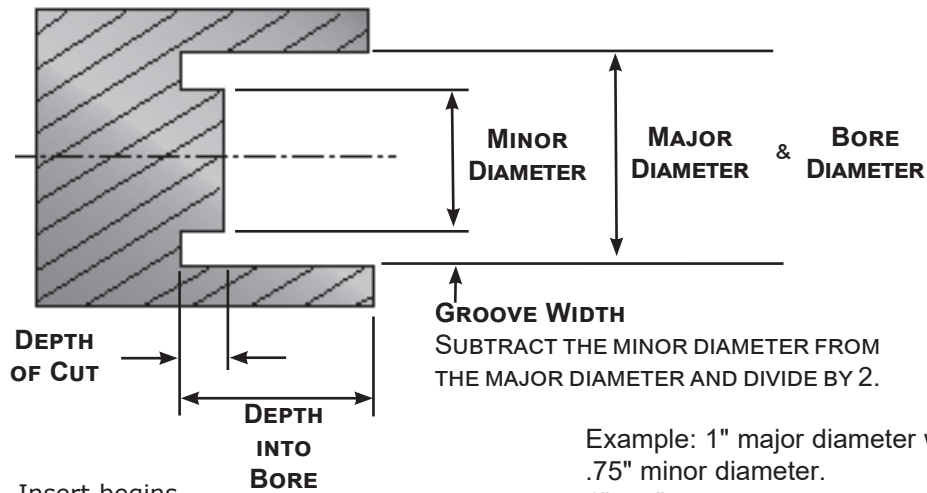

Example: 1" major diameter with .75" minor diameter.

$$\frac{1" - .75"}{2} = .125" \text{ Groove Width}$$

Insert begins with:
LGT, MGTI, FT

Insert begins with:
DGI, DGMI

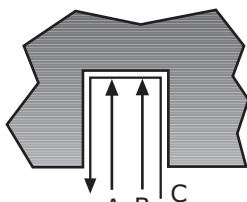
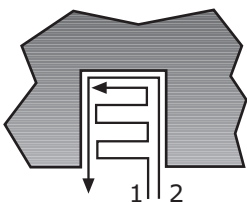

Cutting Paths

Use these diagrams for expanding the size of grooves.

Note: Side load on path 1 should be 10% to 30% of depth of cut on insert.

KAISER TOOL COMPANY, INC.

Phone: 888-THINBIT (888-844-6248) or (260) 484-3620

www.thinbit.com • Orders: orders@thinbit.com • Quotes: quotes@thinbit.com

Speeds & Feeds - Face Grooving						
Material To Be Cut		Carbide			High Speed Steel	
		Carbide Grade	Speed (SFM)	Feed (IPR)	Speed (SFM)	Feed (IPR)
Aluminum	2021-6061	DURA-MAX [®] 5000	1000	.002-.003	525	.002-.003
Brass		DURA-MAX [®] 5000	250	.001	75	.001
Bronze		DURA-MAX [®] 5000	250	.001	70	.001
Cast Iron	Gray	DURA-MAX [®] 5000	300-500	.0017-.0027	35-115	.0017-.0027
	Ductile	DURA-MAX [®] 2000	250-425	.0013-.0027	30-75	.0013-.0027
	Malleable	DURA-MAX [®] 2000	300-600	.0013-.0027	35-120	.0013-.0027
Copper	101-757	DURA-MAX [®] 5000	450-550	.002	80-90	.0013-.0017
	834-978	DURA-MAX [®] 5000	600	.003	325	.0017
Magnesium	AZ, AM, EZ, ZE, HK Types	DURA-MAX [®] 5000	1000	.001-.002	650	.001-.002
Nickel	Nickel 200-230	DURA-MAX [®] 5000	225	.002	80	.001
	Monel	DURA-MAX [®] 5000	45-150	.001-.002	40-55	.001-.002
	Inconel, Waspaloy	DURA-MAX [®] 5000	75-100	.0013	10	.001
	Hastelloy	DURA-MAX [®] 5000	100-125	.0013-.0017	10-15	.001-.0015
Plastic	Teflon (TFE, CTFE)	DURA-MAX [®] 5000	400	.003	250	.003
	Nylon	DURA-MAX [®] 5000	350-600	.002-.003	350	.002-.003
	Phenolic	DURA-MAX [®] 5000	600	.003	350	.003
	Glass Filled	DURA-MAX [®] 5000	250	.002	N/A	N/A
Stainless Steel	201-385	DURA-MAX [®] 5000	225-275	.0013-.002	60-65	.001
	405-446	DURA-MAX [®] 2000	275	.002	90	.001
	14-4, 15-5, 16-6, 17-4 PH	DURA-MAX [®] 2000	125-150	.0013-.002	40-50	.001
Steel	1005-1029	DURA-MAX [®] 2000	400-500	.002-.003	75-110	.002-.003
	1030-1055	DURA-MAX [®] 2000	325-450	.0013-.0027	30-85	.0013-.0027
	1060-1095	DURA-MAX [®] 2000	325-400	.0016-.0027	30-70	.0016-.0027
	10L45-10L50	DURA-MAX [®] 2000	300-600	.0017-.0027	35-130	.0017-.0027
	12L13-12L15	DURA-MAX [®] 2000	500-600	.002-.003	105-130	.002-.003
	41L30-41L50	DURA-MAX [®] 2000	325-500	.0013-.0027	30-105	.0013-.0027
	4140-4150	DURA-MAX [®] 2000	325-450	.0013-.0027	30-95	.0013-.0027
	4140 (35 HRc)	DURA-MAX [®] 2000	350	.0013	45	.0013
	8617-8622	DURA-MAX [®] 2000	250-475	.001-.0023	30-90	.001-.0023
	M1-M6	DURA-MAX [®] 2000	350	.002	50	.001
	H10-H19	DURA-MAX [®] 2000	300-425	.001-.002	35-75	.001-.002
	D2-D7	DURA-MAX [®] 2000	300-375	.002	35-60	.0015-.002
	A2-A9, 01-07	DURA-MAX [®] 2000	300-375	.002	35-60	.0015-.002
	W1, W2	DURA-MAX [®] 2000	425	.002	75	.002
	M-50, 52100	DURA-MAX [®] 2000	350	.002	55	.002
	Titanium	Ti-6Al-6V	DURA-MAX [®] 5000	95	.001	40

THESE SPEEDS AND FEEDS ARE GIVEN AS A STARTING POINT ONLY AND MAY BE ADJUSTED UP OR DOWN DEPENDING ON CONDITIONS. ANY TIME THERE IS AN INTERRUPTED CUT IN YOUR OPERATION, **DURA-MAX[®] 2000** CARBIDE IS RECOMMENDED.

FORMULA FOR CONVERSION FROM SFM TO RPM

SFM = SURFACE FEET PER MINUTE RPM = REVOLUTIONS PER MINUTE IPR = INCHES PER REVOLUTION DIAMETER = CUTTING DIAMETER π = 3.14

For Milling -

Convert RPM to Inches per minute per chip load.
$$RPM = \frac{SFM \times 12}{(\pi) \times DIAMETER}$$

KAISER TOOL COMPANY, INC.

Phone: 888-THINBIT (888-844-6248) or (260) 484-3620
 www.thinbit.com • Orders: orders@thinbit.com • Quotes: quotes@thinbit.com

FACE GROOVING

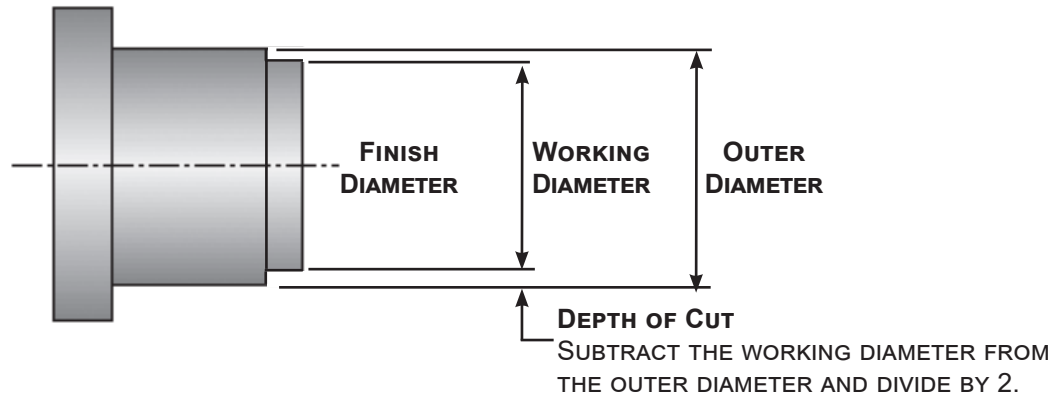

Example: 1" outer diameter with .976" working diameter.

$$\frac{1" - .976"}{2} = .012" \text{ depth of cut}$$

Setup Guide

Turning Applications

Decrease surface speed (SFM)

Increase feed (IPR)

Increase depth of cut

Set tool on center to .005" below center. Keep smaller inserts closer to center.

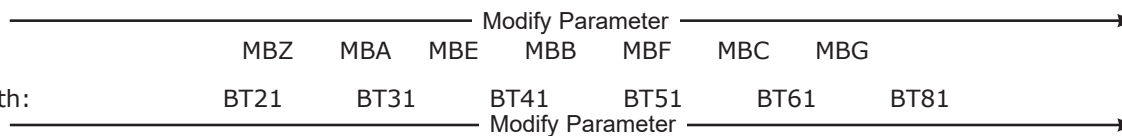

Boring Applications

Decrease surface speed (SFM)

Increase feed (IPR)

Increase depth of cut

Set tool .002" to .010" above center. Keep smaller tools closer to center.

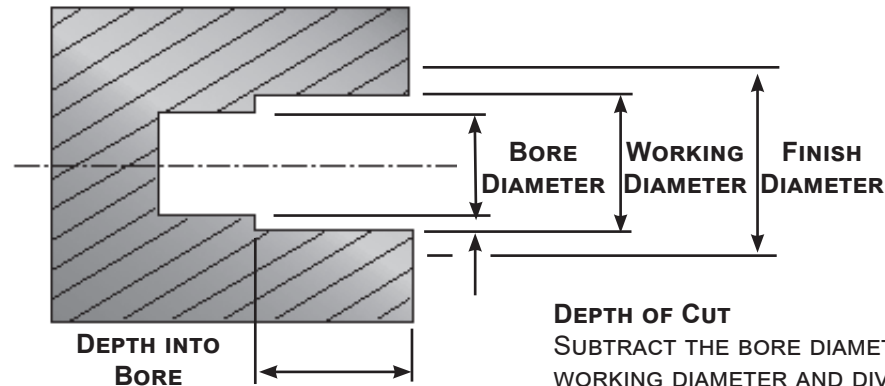

Example: 1" working diameter with .976" bore diameter.

$$\frac{1" - .976"}{2} = .012" \text{ depth of cut}$$

Cutting Paths:

- Internal tools designed for feeding into bore.
- External tools designed for feeding toward chuck.

NUMBER OF PASSES

SUBTRACT THE FINISH DIAMETER FROM THE OUTER DIAMETER AND DIVIDE BY 2 TIMES THE DEPTH OF CUT PER PASS.

Example: 1" outer diameter with .875" finish diameter and .012" per pass.

$$\frac{1" - .875"}{2 \times .012"} = 5.2 \text{ or } 6 \text{ passes}$$

Note: Leave 30% - 50% of depth of cut for finish pass.

KAISER TOOL COMPANY, INC.

Phone: 888-THINBIT (888-844-6248) or (260) 484-3620

www.thinbit.com • Orders: orders@thinbit.com • Quotes: quotes@thinbit.com

Speeds & Feeds - MBE, MBF & MBG Style Inserts							
Material To Be Cut		Carbide Grade	Speed (SFM)	Feed (IPR)	Depth of Cut		
					MBE	MBF	MBG
Aluminum	2021-6061	DURA-MAX [®] 5000	450-1000	.005-.012	.012	.014	.016
Brass		DURA-MAX [®] 5000	300-400	.002-.005	.010	.010	.012
Bronze		DURA-MAX [®] 5000	300-400	.002-.005	.009	.010	.012
Cast Iron	Gray	DURA-MAX [®] 5000	200-300	.005-.010	.010	.012	.015
	Ductile	DURA-MAX [®] 4000	200-300	.005-.010	.010	.012	.015
	Malleable	DURA-MAX [®] 4000	100-300	.005-.010	.010	.012	.015
Copper	101-757	DURA-MAX [®] 4000	400-750	.003-.005	.012	.014	.016
	834-978	DURA-MAX [®] 5000	300-700	.003-.005	.012	.014	.016
Magnesium	AZ, AM, EZ, ZE, HK Types	DURA-MAX [®] 5000	700-1300	.005-.012	.012	.014	.016
Nickel	Nickel 200-230	DURA-MAX [®] 4000	100-250	.002-.005	.008	.008	.008
	Monel	DURA-MAX [®] 4000	80-120	.0005-.001	.008	.008	.008
	Inconel, Waspaloy	DURA-MAX [®] 4000	70-95	.001-.003	.008	.008	.008
	Hastelloy	DURA-MAX [®] 4000	50-80	.001-.003	.008	.008	.008
Plastic	Teflon (TFE, CTFE)	DURA-MAX [®] 5000	500-850	.004-.008	.010	.012	.015
	Nylon	DURA-MAX [®] 5000	700-1000	.002-.005	.010	.012	.015
	Phenolic	DURA-MAX [®] 5000	700-1000	.005	.010	.012	.015
	Glass Filled	DURA-MAX [®] 5000	700-1000	.005	.008	.012	.015
Stainless Steel	201-385	DURA-MAX [®] 4000	100-225	.002-.004	.009	.010	.012
	405-446	DURA-MAX [®] 4000	100-225	.002-.004	.008	.009	.010
	14-4, 15-5, 16-6, 17-4 PH	DURA-MAX [®] 4000	300-400	.002-.004	.008	.009	.010
Steel	1005-1029	DURA-MAX [®] 4000	100-250	.003-.007	.010	.012	.015
	1030-1055	DURA-MAX [®] 4000	100-250	.003-.007	.010	.012	.015
	1060-1095	DURA-MAX [®] 4000	100-350	.003-.007	.010	.012	.015
	10L45-10L50	DURA-MAX [®] 4000	250-450	.006-.008	.010	.012	.015
	12L13-12L15	DURA-MAX [®] 4000	250-450	.004-.006	.010	.012	.015
	41L30-41L50	DURA-MAX [®] 4000	150-350	.003-.007	.010	.012	.015
	4140-4150	DURA-MAX [®] 4000	100-350	.003-.007	.010	.012	.015
	4140 (35 HRC)	DURA-MAX [®] 4000	90-125	.003-.007	.008	.008	.010
	8617-8622	DURA-MAX [®] 4000	100-200	.004-.008	.010	.012	.015
	M1-M6	DURA-MAX [®] 4000	100-200	.004-.008	.008	.010	.012
	H10-H19	DURA-MAX [®] 4000	100-200	.004-.008	.008	.010	.012
	D2-D7	DURA-MAX [®] 4000	100-200	.004-.008	.008	.010	.012
	A2-A9, 01-07	DURA-MAX [®] 4000	100-200	.004-.008	.008	.010	.012
	W1, W2	DURA-MAX [®] 4000	100-200	.004-.008	.008	.010	.012
	M-50, 52100	DURA-MAX [®] 4000	200-300	.005-.010	.010	.012	.015
Titanium	Ti-6Al-6V	DURA-MAX [®] 5000	90-250	.001-.003	.008	.009	.010

THESE SPEEDS AND FEEDS ARE GIVEN AS A STARTING POINT ONLY AND MAY BE ADJUSTED UP OR DOWN DEPENDING ON CONDITIONS. ANY TIME THERE IS AN INTERRUPTED CUT IN YOUR OPERATION, **DURA-MAX[®] 4000** CARBIDE IS RECOMMENDED.

FORMULA FOR CONVERSION FROM SFM TO RPM

SFM = SURFACE FEET PER MINUTE RPM = REVOLUTIONS PER MINUTE IPR = INCHES PER REVOLUTION DIAMETER = CUTTING DIAMETER π = 3.14

$$RPM = \frac{SFM \times 12}{(\pi) \times DIAMETER}$$

KAISER TOOL COMPANY, INC.

Phone: 888-THINBIT (888-844-6248) or (260) 484-3620
 www.thinbit.com • Orders: orders@thinbit.com • Quotes: quotes@thinbit.com



Speeds & Feeds - MBZ, MBA, MBB, MBC Style Inserts & MICROBIT® Solid Carbide Tools

Material To Be Cut		Carbide Grade			Depth of Cut		
		MBA, MBB, MBC, MBZ	Speed (SFM)	Feed (IPR)	MBA, MBZ, BT2, BT3	MBB, BT4, BT5	MBC, BT6, BT8
Aluminum	2021-6061	DURA-MAX® 5000	700-1400	.005-.012	.008	.008	.016
Brass		DURA-MAX® 5000	350-400	.001-.003	.006	.006	.012
Bronze		DURA-MAX® 5000	300-400	.001-.002	.006	.006	.012
Cast Iron	Gray	DURA-MAX® 5000	250-350	.004-.010	.007	.007	.015
	Ductile	DURA-MAX® 5000	250-350	.004-.010	.007	.007	.015
	Malleable	DURA-MAX® 5000	250-350	.004-.010	.007	.007	.015
Copper	101-757	DURA-MAX® 5000	600-800	.003-.005	.008	.008	.016
	834-978	DURA-MAX® 5000	600-800	.003-.005	.008	.008	.016
Magnesium	AZ, AM, EZ, ZE, HK Types	DURA-MAX® 5000	750-1500	.005-.012	.008	.008	.016
Nickel	Nickel 200-230	DURA-MAX® 5000	100-250	.002-.005	.004	.004	.008
	Monel	DURA-MAX® 5000	80-120	.001-.003	.004	.004	.008
	Inconel, Waspaloy	DURA-MAX® 5000	80-120	.001-.003	.004	.004	.008
	Hastelloy	DURA-MAX® 5000	80-120	.001-.003	.004	.004	.008
Plastic	Teflon (TFE, CTFE)	DURA-MAX® 5000	500-600	.003-.006	.007	.007	.015
	Nylon	DURA-MAX® 5000	700-800	.001-.003	.007	.007	.015
	Phenolic	DURA-MAX® 5000	700-800	.001-.003	.007	.007	.015
	Glass Filled	DURA-MAX® 5000	700-800	.001-.003	.005	.005	.015
Stainless Steels	201-385	DURA-MAX® 5000	100-250	.0015-.004	.005	.005	.010
	405-446	DURA-MAX® 5000	100-250	.0015-.004	.005	.005	.010
	14-4, 15-5, 16-6, 17-4 PH	DURA-MAX® 5000	300-400	.002-.004	.005	.005	.010
Steel	1005-1029	DURA-MAX® 3000/4000	100-300	.003-.007	.007	.007	.015
	1030-1055	DURA-MAX® 3000/4000	100-300	.003-.007	.007	.007	.015
	1060-1095	DURA-MAX® 3000/4000	150-400	.003-.005	.007	.007	.015
	10L45-10L50	DURA-MAX® 3000/4000	300-500	.004-.006	.007	.007	.015
	12L13-12L15	DURA-MAX® 3000/4000	300-500	.003-.005	.007	.007	.015
	41L30-41L50	DURA-MAX® 3000/4000	200-400	.003-.005	.007	.007	.015
	4140-4150	DURA-MAX® 3000/4000	150-400	.003-.005	.007	.007	.015
	4140 (35 HRc)	DURA-MAX® 3000/4000	90-125	.001-.004	.004	.004	.008
	8617-8622	DURA-MAX® 3000/4000	100-300	.002-.004	.007	.007	.015
	M1-M6	DURA-MAX® 3000/4000	150-250	.003-.008	.006	.006	.012
	H10-H19	DURA-MAX® 3000/4000	150-250	.003-.007	.006	.006	.012
	D2-D7	DURA-MAX® 3000/4000	150-250	.004-.010	.006	.006	.012
	A2-A9, 01-07	DURA-MAX® 3000/4000	150-250	.003-.008	.006	.006	.012
	W1, W2	DURA-MAX® 3000/4000	150-250	.003-.008	.006	.006	.012
	M-50, 52100	DURA-MAX® 3000/4000	300-400	.004-.010	.007	.007	.015
Titanium	Ti-6Al-6V	DURA-MAX® 5000	90-250	.001-.003	.005	.005	.010

THESE SPEEDS AND FEEDS ARE GIVEN AS A STARTING POINT ONLY AND MAY BE ADJUSTED UP OR DOWN DEPENDING ON CONDITIONS.
 ANY TIME THERE IS AN INTERRUPTED CUT IN YOUR OPERATION, **DURA-MAX® 3000/4000** CARBIDE IS RECOMMENDED.

FORMULA FOR CONVERSION FROM SFM TO RPM

SFM = SURFACE FEET PER MINUTE RPM = REVOLUTIONS PER MINUTE IPR = INCHES PER REVOLUTION DIAMETER = CUTTING DIAMETER $\pi = 3.14$

$$RPM = \frac{SFM \times 12}{(\pi) \times DIAMETER}$$

KAISER TOOL COMPANY, INC.

Phone: 888-THINBIT (888-844-6248) or (260) 484-3620
 www.thinbit.com • Orders: orders@thinbit.com • Quotes: quotes@thinbit.com

Speeds & Feeds - DURA-MAX® 9000 (PCD Tipped) Insert					
Material To Be Cut	Speed (SFM)	Feed (IPR)	Depth of Cut		
			MBA	MBB	MBC
Aluminum (High Silicon)	1000-2000	.003-.010	.001-.007	.002-.008	.003-.012
Bronze, Brass	800-1500	.003-.010	.001-.007	.002-.008	.003-.012
Copper Alloys	800-1200	.003-.010	.001-.007	.002-.008	.003-.012
Fiberglass	500-900	.001-.005	.001-.007	.002-.008	.003-.012
Green Carbide	500-1400	.001-.004	.001-.007	.002-.008	.003-.012
Monel	1000-2000	.003-.010	.001-.007	.002-.008	.003-.012
Phenolic	500-900	.001-.005	.001-.007	.002-.008	.003-.012
Plastics	500-900	.001-.004	.001-.007	.002-.008	.003-.012

THESE SPEEDS AND FEEDS ARE GIVEN AS A STARTING POINT ONLY AND MAY BE ADJUSTED UP OR DOWN DEPENDING ON CONDITIONS. ANY TIME THERE IS AN INTERRUPTED CUT IN YOUR OPERATION, **DURA-MAX® 3000 & 4000** CARBIDES ARE RECOMMENDED.

Speeds & Feeds - DURA-MAX® 8000 (CBN Tipped) Insert					
Material To Be Cut	Speed (SFM)	Feed (IPR)	Depth of Cut		
			MBA	MBB	MBC
52100 (58-62 HRC)	300-500	.003-.007	.001-.007	.002-.008	.003-.012
Hardened Alloy Steel	200-400	.003-.007	.001-.007	.002-.008	.003-.012
Hardened High Carbon Steel	300-500	.003-.007	.001-.007	.002-.008	.003-.012
Hardened Tool Steel	150-300	.002-.005	.001-.007	.002-.008	.003-.012
NI-Hard Cast Iron	100-300	.007-.015	.001-.007	.002-.008	.003-.012
Pearlitic Gray Cast Iron	800-1800	.007-.015	.001-.007	.002-.008	.003-.012
Powdered Metal	350-500	.003-.007	.001-.007	.002-.008	.003-.012
Stellite	100-200	.002-.004	.001-.007	.002-.008	.003-.012
Super Alloys	400-900	.003-.007	.001-.007	.002-.008	.003-.012
Thermal Spray Co Based	200-600	.002-.005	.001-.007	.002-.008	.003-.012
Thermal Spray Ni Based	150-450	.002-.007	.001-.007	.002-.008	.003-.012

FORMULA FOR CONVERSION FROM SFM TO RPM

SFM = SURFACE FEET PER MINUTE
RPM = REVOLUTIONS PER MINUTE
IPR = INCHES PER REVOLUTION
DIAMETER = CUTTING DIAMETER
 $\pi = 3.14$

$$RPM = \frac{SFM \times 12}{(\pi) \times DIAMETER}$$

ANSI STANDARD INSERT IDENTIFICATION SYSTEM

References to "insert type" in this catalog are based upon the ANSI B212.4-1995 system. The two letter codes refer to shape and relief angle. The use of four letter codes adds the tolerances and type (or configuration) to the first two letters. Following are the codes used for our inserts:

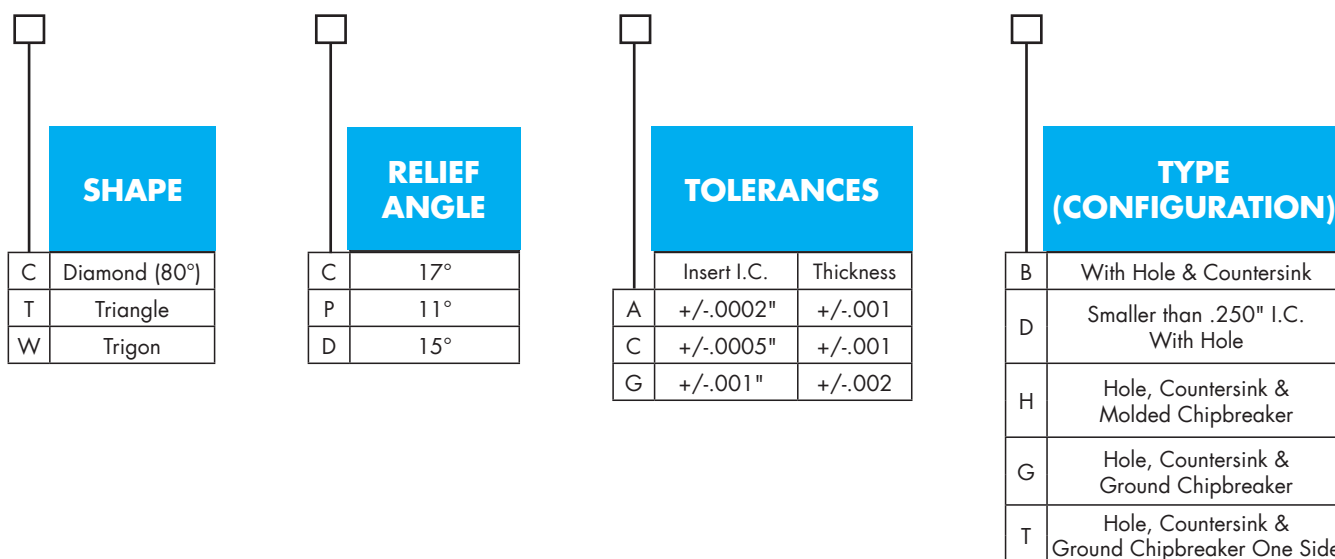

BORING

KAISER TOOL COMPANY, INC.

Phone: 888-THINBIT (888-844-6248) or (260) 484-3620
www.thinbit.com • Orders: orders@thinbit.com • Quotes: quotes@thinbit.com

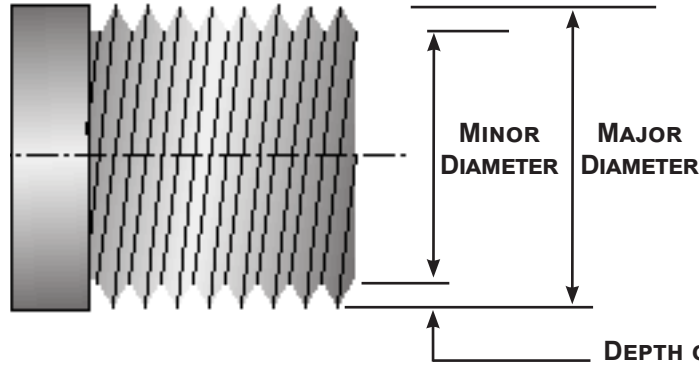

DEPTH OF THREAD
 SUBTRACT THE MINOR DIAMETER FROM THE MAJOR DIAMETER AND DIVIDE BY 2.

Example: 1" major diameter with .754" minor diameter.

$$\frac{1" - .754"}{2} = .123" \text{ depth of thread}$$

Setup Guide

External Threading Applications

Decrease surface speed (SFM)
 Increase depth of cut per pass
 Set tool on center to .005" below center. Keep smaller inserts closer to center.

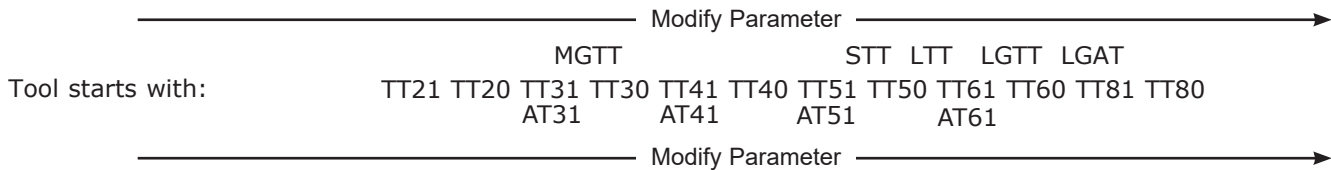

Internal Threading Applications

Decrease surface speed (SFM)
 Decrease depth of cut per pass
 Set tool .002" to .010" above center. Keep smaller tools closer to center.

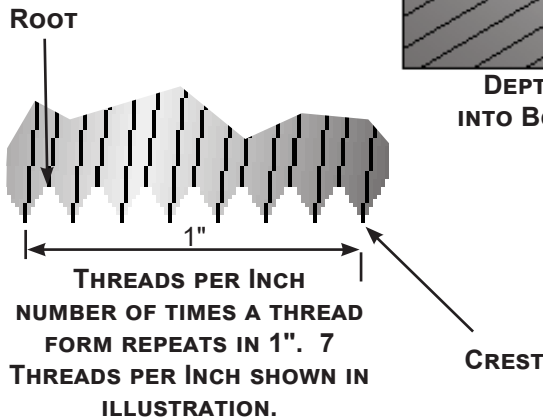
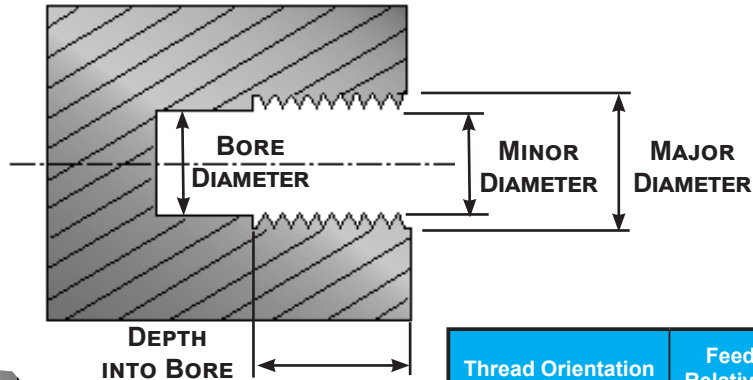

PITCH = 1/THREADS PER INCH
DEPTH OF INTERNAL THREADS = .54127 X PITCH
DEPTH OF EXTERNAL THREADS = .86603 X PITCH

Thread Orientation	Feed Direction Relative to Spindle	Chuck Rotation
Right Hand, External	Toward	Counter-Clockwise
	Away	Clockwise
Left Hand, External	Toward	Clockwise
	Away	Counter-Clockwise
Right Hand, Internal	Toward	Counter-Clockwise
	Away	Clockwise
Left Hand, Internal	Toward	Clockwise
	Away	Counter-Clockwise

KAISER TOOL COMPANY, INC.

Phone: 888-THINBIT (888-844-6248) or (260) 484-3620
 www.thinbit.com • Orders: orders@thinbit.com • Quotes: quotes@thinbit.com

Speeds & Feeds - Threading						
Material To Be Cut		Carbide Grade	Speed (SFM)		Infeed Per Pass (IPR)	
			Carbide	HSS	1st Pass	Last Pass
Aluminum	2021-6061	DURA-MAX [®] 5000	100-200	80-150	.020	.001
Brass		DURA-MAX [®] 5000	200-300	50-150	.010	.001
Bronze		DURA-MAX [®] 5000	200-300	50-150	.010	.001
Cast Iron	Gray, Ductile, Malleable	DURA-MAX [®] 2000	85-140	25-50	.015	.0005
Copper	101-757, 834-978	DURA-MAX [®] 5000	100-200	30-100	.010	.001
Magnesium	AZ, AM, EZ, ZE, HK Types	DURA-MAX [®] 5000	100-200	80-150	.020	.001
Nickel	Nickel 200-230, Monel, Inconel	DURA-MAX [®] 5000	40-100	20-25	.015	.001
	Waspaloy, Hastelloy	DURA-MAX [®] 5000	40-100	20-25	.015	.001
Plastic	Teflon (TFE, CTFE)	DURA-MAX [®] 5000	250-400	100-300	.015	.001
	Nylon	DURA-MAX [®] 5000	250-400	100-300	.015	.001
	Phenolic	DURA-MAX [®] 5000	250-400	100-300	.015	.001
	Glass Filled	DURA-MAX [®] 5000	250-400	NA	.015	.001
Stainless Steel	201-385	DURA-MAX [®] 5000	65-100	8-20	.015	.001
	405-446	DURA-MAX [®] 2000	65-100	8-20	.015	.001
	14-4, 15-5, 16-6, 17-4 PH	DURA-MAX [®] 2000	65-100	8-20	.015	.001
Steel	1005-1029, 1030-1055	DURA-MAX [®] 2000	50-150	30-40	.015	.001
	1060-1095, 10L45-10L50	DURA-MAX [®] 2000	50-150	30-40	.015	.001
	12L13-12L15, 41L30-41L50	DURA-MAX [®] 2000	50-150	30-40	.015	.001
	4140-4150, 4140 (35 HRC)	DURA-MAX [®] 2000	50-150	30-40	.015	.001
	8617-8622, M1-M6	DURA-MAX [®] 2000	50-150	30-40	.015	.001
	D2-D7, A2-A9, 01-07	DURA-MAX [®] 2000	50-150	30-40	.015	.001
	W1, W2, M-50, 52100	DURA-MAX [®] 2000	50-150	30-40	.015	.001
Titanium	Ti-6Al-6V	DURA-MAX [®] 5000	40-65	5-9	.020	.0005

Single Point Threading - Roughing Infeed Depth per Pass (Based on Equal Areas of Material Removal per Pass)														
Pass	Threads Per Inch													
	8	10	11	12	13	14	16	18	20	24	28	32	36	40
1st	.017	.015	.013	.013	.012	.011	.011	.011	.010	.009	.008	.008	.007	.008
2nd	.028	.024	.022	.022	.020	.019	.018	.018	.016	.015	.013	.013	.011	.013
3rd	.037	.032	.029	.029	.026	.024	.023	.023	.021	.019	.016	.017	.015	
4th	.045	.038	.035	.035	.032	.029	.028	.028	.025	.023	.019			
5th	.052	.044	.040	.040	.036	.034	.032	.032	.028					
6th	.058	.049	.045	.044	.041	.038	.036							
7th	.064	.054	.049	.049	.045	.041								
8th	.069	.059	.053											
9th	.074													

Note: One or more finish passes will be necessary to finish the thread

THESE SPEEDS AND FEEDS ARE GIVEN AS A STARTING POINT ONLY AND MAY BE ADJUSTED UP OR DOWN DEPENDING ON CONDITIONS. ANY TIME THERE IS AN INTERRUPTED CUT IN YOUR OPERATION, **DURA-MAX[®] 2000** CARBIDE IS RECOMMENDED.

FORMULA FOR CONVERSION FROM SFM TO RPM

SFM = SURFACE FEET PER MINUTE RPM = REVOLUTIONS PER MINUTE IPR = INCHES PER REVOLUTION DIAMETER = CUTTING DIAMETER $\pi = 3.14$

$$RPM = \frac{SFM \times 12}{\pi \times DIAMETER}$$

KAISER TOOL COMPANY, INC.

Phone: 888-THINBIT (888-844-6248) or (260) 484-3620
 www.thinbit.com • Orders: orders@thinbit.com • Quotes: quotes@thinbit.com

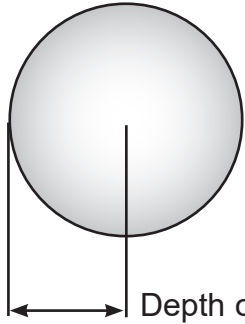

Depth of Cut to part
Solid:

Divide outside diameter by 2

Example: 1" outside diameter

$$\frac{1"}{2} = .5" \text{ depth of cut to part}$$

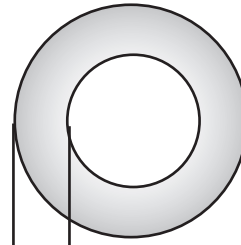

Depth of Cut to part
Tubing:

Subtract inside diameter from
outside diameter and divide by 2

Example: 1" outside diameter with
.5" inside diameter.

$$\frac{1"-.5"}{2} = .25" \text{ depth of cut to part}$$

External Parting Applications

Decrease surface speed (SFM)

Increase depth of cut per pass

Set tool on center to .005" below center. Keep smaller inserts closer to center.

Modify Parameter →

Tool starts with:

LGPT025
SPT025

LGPT045
SPT045

LGPT062
SPT062

LGPT085
LPT085

LGPT115
LPT115

KAISER TOOL COMPANY, INC.

Phone: 888-THINBIT (888-844-6248) or (260) 484-3620

www.thinbit.com • Orders: orders@thinbit.com • Quotes: quotes@thinbit.com

Speeds & Feeds - Parting						
Material To Be Cut		Carbide Grade	Carbide		High Speed Steel	
			Speed (SFM)	Feed (IPR)	Speed (SFM)	Feed (IPR)
Aluminum	2021-6061	DURA-MAX [®] 5000	650-1100	.002-.004	300-500	.002-.004
Brass		DURA-MAX [®] 5000	200-350	.001-.003	50-100	.001-.003
Bronze		DURA-MAX [®] 5000	200-350	.001-.003	50-100	.001-.003
Cast Iron	Gray	DURA-MAX [®] 5000	100-350	.0015-.005	30-125	.0015-.005
	Ductile	DURA-MAX [®] 2000	200-400	.003-.006	100-200	.003-.006
	Malleable	DURA-MAX [®] 2000	250-550	.003-.006	100-200	.003-.006
Copper	101-757	DURA-MAX [®] 5000	150-300	.002-.004	50-150	.002-.004
	834-978	DURA-MAX [®] 5000	250-600	.002-.006	100-450	.002-.006
Magnesium	AZ, AM, EZ, ZE, HK Types	DURA-MAX [®] 5000	600-1000	.002-.004	300-500	.002-.004
Nickel	Nickel 200-230	DURA-MAX [®] 5000	200-350	.002-.004	50-100	.002-.004
	Monel	DURA-MAX [®] 5000	100-250	.0025-.003	30-80	.002-.003
	Inconel, Waspaloy	DURA-MAX [®] 5000	50-150	.002-.004	25-75	.001-.003
	Hastelloy	DURA-MAX [®] 5000	50-150	.002-.004	25-75	.001-.003
Plastic	Teflon (TFE, CTFE)	DURA-MAX [®] 5000	300-600	.002-.006	100-300	.002-.006
	Nylon	DURA-MAX [®] 5000	250-400	.002-.005	NA	NA
	Phenolic	DURA-MAX [®] 5000	250-400	.002-.005	200-350	.002-.005
	Glass Filled	DURA-MAX [®] 5000	200-350	.002-.007	NA	NA
Stainless Steel	201-385	DURA-MAX [®] 5000	200-350	.002-.004	75-150	.001-.003
	405-446	DURA-MAX [®] 2000	250-450	.002-.003	50-100	.001-.003
	14-4, 15-5, 16-6, 17-4 PH	DURA-MAX [®] 2000	200-350	.002-.003	50-100	.001-.003
Steel	1005-1029	DURA-MAX [®] 2000	250-400	.0015-.004	100-200	.0015-.004
	1030-1055	DURA-MAX [®] 2000	200-325	.001-.003	75-100	.001-.003
	1060-1095	DURA-MAX [®] 2000	150-300	.001-.003	60-100	.001-.003
	10L45-10L50	DURA-MAX [®] 2000	250-400	.001-.003	100-200	.001-.003
	12L13-12L15	DURA-MAX [®] 2000	250-550	.002-.005	100-300	.002-.005
	41L30-41L50	DURA-MAX [®] 5000	150-400	.002-.005	45-150	.002-.005
	4140-4150	DURA-MAX [®] 2000	150-400	.002-.005	45-150	.002-.005
	4140 (35 HRc)	DURA-MAX [®] 2000	100-250	.001-.004	30-75	.001-.004
	8617-8622	DURA-MAX [®] 2000	150-400	.002-.004	50-150	.001-.004
	M1-M6	DURA-MAX [®] 2000	150-300	.001-.002	50-150	.001-.002
	H10-H19	DURA-MAX [®] 2000	100-350	.001-.002	50-150	.001-.002
	D2-D7	DURA-MAX [®] 2000	100-300	.001-.002	50-100	.001-.002
	A2-A9, 01-07	DURA-MAX [®] 2000	100-300	.001-.0025	100-200	.001-.002
	W1, W2	DURA-MAX [®] 2000	200-400	.002-.0035	75-175	.001-.003
	M-50, 52100	DURA-MAX [®] 2000	175-350	.0015-.004	50-125	.001-.0035
Titanium	Ti-6Al-6V	DURA-MAX [®] 5000	150-350	.0015-.004	30-100	.001-.003

THESE SPEEDS AND FEEDS ARE GIVEN AS A STARTING POINT ONLY AND MAY BE ADJUSTED UP OR DOWN DEPENDING ON CONDITIONS. ANY TIME THERE IS AN INTERRUPTED CUT IN YOUR OPERATION, **DURA-MAX[®] 2000** CARBIDE IS RECOMMENDED.

FORMULA FOR CONVERSION FROM SFM TO RPM

SFM = SURFACE FEET PER MINUTE RPM = REVOLUTIONS PER MINUTE IPR = INCHES PER REVOLUTION DIAMETER = CUTTING DIAMETER π = 3.14

$$RPM = \frac{SFM \times 12}{(\pi) \times DIAMETER}$$

KAISER TOOL COMPANY, INC.

Phone: 888-THINBIT (888-844-6248) or (260) 484-3620
 www.thinbit.com • Orders: orders@thinbit.com • Quotes: quotes@thinbit.com

PARTING

LITTLE :BT® O.D./I.D. GROOVING INSERTS

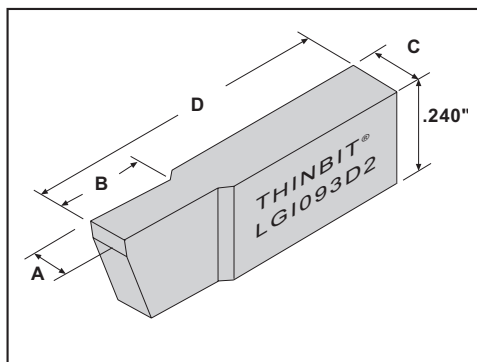

FRONT RAKE:
 CARBIDE: Primary 10° honed, Secondary 15°
 HIGH SPEED STEEL: 15°
 BACK CLEARANCE: 2-1/2° both sides
 SIDE CLEARANCE: 0° both sides
 RADIUS: Sharp corner through full radius available
 TOP RAKE: 0°
 LEAD ANGLE: 0°
 'A' TOLERANCE:
 .004" - .063": +.0009"/-.0000"
 .064" - .125": +.001"/-.001"

PRODUCT INFORMATION	<ul style="list-style-type: none"> This insert style will cut to within 1/16" of a shoulder. To work against a shoulder see Page 1-10. Sub-micron grain DURA-MAX® 2000 and 5000 Carbides and High Speed Steel. Inserts available with TiN, TiAlN, TiCN and Diamond coating.
----------------------------	--

TECHNICAL SECTIONS	SPEEDS AND FEEDS	APPLICATION REFERENCE	TROUBLESHOOTING
	PG 9-10	PGS 9-3 & 9-4	PG 9-7

ORDERING INSTRUCTIONS

Complete the **ORDER CODE** in the table below that represents your selection of groove width and insert grade.

EXAMPLE:

The **ORDER CODE** for an .093" groove width insert in **DURA-MAX® 2000** is:
LGI 093 D2

Specify the Tool Width 'A' ↑

SPECIFICATIONS		ORDER CODE					INFORMATION			
Insert Width Range	Depth of Cut	Insert Grades <small>See Page 9-5 for expanded material descriptions and Page 9-10 for Speeds and Feeds information</small>			Add-ons <small>Use 'Order Code' and Add</small>			Blank Width	Overall Length	Toolholder Catalog Section 7 & 10
'A'	'B'	DURA-MAX® 2000 Carbide <small>For Steel & Interrupted Cutting</small>	DURA-MAX® 5000 Carbide <small>For Aluminum & Nonferrous</small>	High Speed Steel	Full Radius Page 8-3	Corner Radius Page 8-3	Coating Page 9-6	'C'	'D'	Use Toolholders Beginning With
.004"-.034"	3 x 'A'							.068"	.650"	'S' 'EM' 'ROM' Page 10-5 through 10-8
.035"-.063"	.100"	SGI ___ D2	SGI ___ D5	SGI ___ HS			TiN add 'C' TiCN add 'D'			
.064"-.125"	1.5 x 'A'	LGI ___ D2	LGI ___ D5	LGI ___ HS	add 'FR'	(indicate size in .xxx")	TiAlN add 'E' Diamond add 'F'	.130"	.721"	'L' 'EM' 'ROM' Section 7 Page 10-5 through 10-8

KAISER TOOL COMPANY, INC.

Phone: 888-THINBIT (888-844-6248) or (260) 484-3620
 www.thinbit.com • Orders: orders@thinbit.com • Quotes: quotes@thinbit.com

LITTLE BIT® PARTING INSERTS

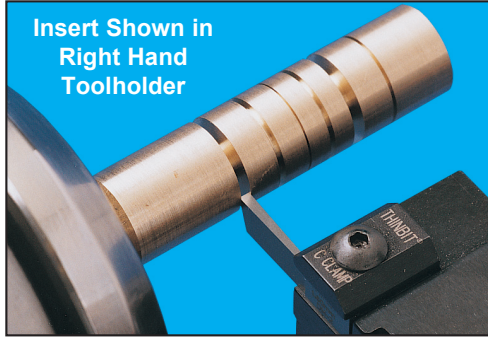

Insert Shown in Right Hand Toolholder

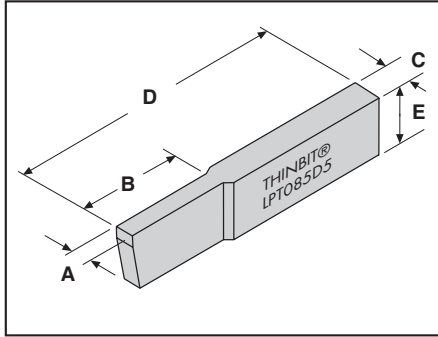

FRONT RAKE:
 CARBIDE: Primary 7° honed, Secondary 15°
 HIGH SPEED STEEL: 15° on SPT025HS,
 7° all others

BACK CLEARANCE: 0° SPT045HS and
 SPT062HS; 1° all others

SIDE CLEARANCE: 1°

RADIUS: None

TOP RAKE: 0°

LEAD ANGLE: 0°

'A' TOLERANCE: .025" - .115": +.001"/-.001"

GROOVING & PARTING INSERTS

PRODUCT INFORMATION	<ul style="list-style-type: none"> This insert style will cut to within 1/16" of a shoulder. .025", .045", .062", .085" and .115" Parting off up to 1" diameter Centered Sub-micron grain DURA-MAX® 2000 and 5000 Carbides and High Speed Steel. Inserts available with TiN, TiAlN, TiCN and Diamond coating.
----------------------------	---

TECHNICAL SECTIONS	SPEEDS AND FEEDS	APPLICATION REFERENCE	TROUBLESHOOTING
	PG 9-20	PG 9-4	PG 9-7

ORDERING INSTRUCTIONS

Select the **ORDER CODE** in the table below that represents your selection of groove width and insert grade.

EXAMPLE:

The **ORDER CODE** for an .085" wide parting insert in **DURA-MAX® 5000** is:
LPT085D5

SPECIFICATIONS		ORDER CODE				INFORMATION						
Groove Width	Depth of Cut	Insert Grades <small>See Pages 9-5 for expanded material descriptions and Page 9-20 for Speeds and Feeds information</small>			Coatings <small>See Page 9-6 for expanded coating descriptions</small>				Blank Width	Overall Length	Blank Height	Toolholder Catalog Section 7 & 10
'A'	'B'	DURA-MAX® 2000 Carbide <small>For Steel & Interrupted Cutting</small>	DURA-MAX® 5000 Carbide <small>For Aluminum & Nonferrous</small>	High Speed Steel	Use uncoated part number and add coating code				'C'	'D'	'E'	Use Toolholders Beginning With
					TiN	TiCN	TiAlN	Diamond				
.025"	.200"	SPT025D2	SPT025D5	SPT025HS						.650"		'S' 'EM' 'ROM' Page 10-5 through 10-8
.045"	.500"	SPT045D2	SPT045D5	SPT045HS	add 'C'	add 'D'	add 'E'	add 'F'	.068"	.240"		
.062"		SPT062D2	SPT062D5	SPT062HS					1.000"			
.085"	.500"	LPT085D2	LPT085D5							.238"	'L' 'EM' 'ROM' Section 7 Page 10-5 through 10-8	
.115"		LPT115D2	LPT115D5		add 'C'	add 'D'	add 'E'	add 'F'	.125"	1.000"		.232"

KAISER TOOL COMPANY, INC.

Phone: 888-THINBIT (888-844-6248) or (260) 484-3620
 www.thinbit.com • Orders: orders@thinbit.com • Quotes: quotes@thinbit.com

LITTLE BIT® O.D./I.D. THREADING INSERTS

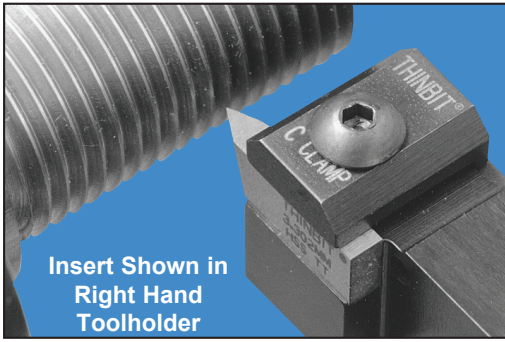

Insert Shown in Right Hand Toolholder

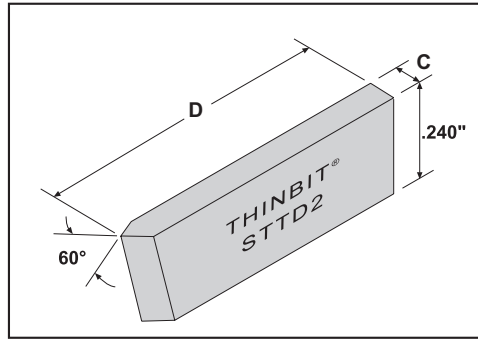

FRONT RAKE: 15°
 RADIUS: .002" or .000"
 TOP RAKE: 0°
 PROFILE: 60°

PRODUCT INFORMATION	<ul style="list-style-type: none"> • External threading within .046" of a shoulder. • Internal threading with 1.250" minimum bore diameter. • 8 Threads Per Inch and greater. • Sub-micron grain DURA-MAX® 2000 and 5000 Carbides and High Speed Steel. • Inserts can be coated with TiN, TiAlN, TiCN and Diamond coating.
----------------------------	---

TECHNICAL SECTIONS	SPEEDS AND FEEDS	APPLICATION REFERENCE	TROUBLESHOOTING
	PG 9-18	PG 9-4	PG 9-7

ORDERING INSTRUCTIONS

Complete the **ORDER CODE** in the table below that represents your selection of Threads Per Inch and insert grade.

EXAMPLE:

The **ORDER CODE** for an 15-56 TPI insert in **DURA-MAX® 2000** is:
STTD2

SPECIFICATIONS		ORDER CODE							INFO.		
Insert Orientation	Threads Per Inch	Insert Grades <small>See Page 9-5 for expanded material selections and Page 9-18 for Speeds and Feeds information</small>			Coatings <small>See Page 9-6 for Expanded Coating Descriptions</small>				Blank Width 'C'	Overall Length 'D'	Toolholder Catalog Section 7 & 10 Use Toolholders Beginning With
		DURA-MAX® 2000 Carbide <small>For Steel & Interrupted Cutting</small>	DURA-MAX® 5000 Carbide <small>For Aluminum & Non-ferrous</small>	High Speed Steel	Use Uncoated Part Number and Add Coating Code						
					TiN	TiCN	TiAlN	Diamond			
Centered For either right hand or left hand	15 to 56	STTD2	STTD5	STTHS	add 'C'	add 'D'	add 'E'	add 'F'	.068"	.650"	'S'
	Greater than 56	STTD21	STTD51	STTHS1							Page 10-5 through 10-8
	8 to 56	LTTD2	LTTD5	LTTHS	add 'C'	add 'D'	add 'E'	add 'F'	.130"	.721"	'L'
	Greater than 56	LTTD21	LTTD51	LTTHS1							Section 7 Page 10-5 through 10-8

KAISER TOOL COMPANY, INC.

Phone: 888-THINBIT (888-844-6248) or (260) 484-3620
 www.thinbit.com • Orders: orders@thinbit.com • Quotes: quotes@thinbit.com

LITTLE BIT® GROUND BLANKS & GROOVING INSERT SETS

FRONT RAKE: 7° on SGP068HS; 15° all others

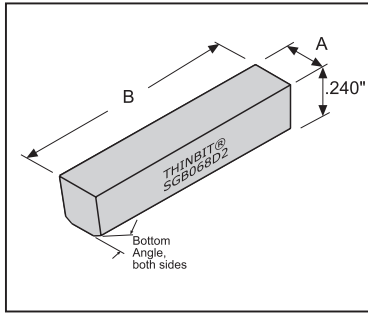

GROUND BLANK ORDERING INSTRUCTIONS

Select the **ORDER CODE** in the table below that represents your selection of blank width and insert grade.

EXAMPLE:

The **ORDER CODE** for a .068" wide blank and .654" length in **DURA-MAX® 2000** is:
SGB068D2

BLANKS & SETS

SPECIFICATIONS			ORDER CODE			INFO.
Blank Width 'A'	Overall Length 'B'	Bottom Angle	Insert Grades See Page 9-5 for expanded material descriptions			Use Toolholders Beginning With
			DURA-MAX® 2000 Carbide For Steel & Interrupted Cutting	DURA-MAX® 5000 Carbide For Aluminum & Nonferrous	High Speed Steel	
.068"	.654"	0°	SGB068D2	SGB068D5	SGB068HS	'S'
	1.004"	0°	SGP068D2	SGP068D5	SGP068HS	
.125"	1.004"	0°	LGP125D2	LGP125D5		'L'
.130"	.725"	10°	LGB130D2	LGB130D5	LGB130HS	

SET ORDERING INSTRUCTIONS

Select the **ORDER CODE** in the table below that represents your selection of insert width(s) and insert grade.

For '1 Each' set types, specify the size range with the 'Order Code'

EXAMPLE:

The **ORDER CODE** for a '1 Each' set type, in **DURA-MAX® 2000** with a groove width range of .010"-.030" is: **SSET2D2**

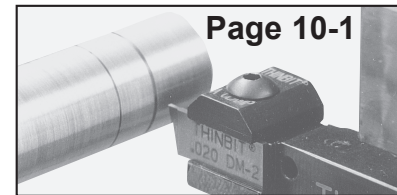

SPECIFICATIONS			ORDER CODE		
Toolholder Type	Set Type	Insert Width 'A' See Page 10-1	Insert Grades See Page 9-5 for expanded material descriptions and Page 9-10 for Speeds and Feeds information		
			DURA-MAX® 2000 Carbide For Steel & Interrupted Cutting Uncoated	DURA-MAX® 5000 Carbide For Aluminum & Non-ferrous Uncoated	High Speed Steel
Inserts only; Use toolholders beginning with 'S' Page 10-5 through 10-8	1 Each, by .001" increments Inserts Only	.004"-.009"	SSET1D2	SSET1D5	SSET1HS
		.010"-.030"	SSET2D2	SSET2D5	SSET2HS
		.031"-.050"	SSET3D2	SSET3D5	SSET3HS
		.051"-.063"	SSET4D2	SSET4D5	SSET4HS
Inserts only; Use toolholders beginning with 'L' Section 7 Page 10-5 through 10-8	1 Each, by .001" increments Inserts Only	.064"-.084"	LSET1D2	LSET1D5	LSET1HS
		.085"-.105"	LSET2D2	LSET2D5	LSET2HS
		.106"-.125"	LSET3D2	LSET3D5	LSET3HS

KAISER TOOL COMPANY, INC.

Phone: 888-THINBIT (888-844-6248) or (260) 484-3620
www.thinbit.com • Orders: orders@thinbit.com • Quotes: quotes@thinbit.com

LITTLE BIT® FLUSHTOP & HARDINGE TOOLHOLDERS

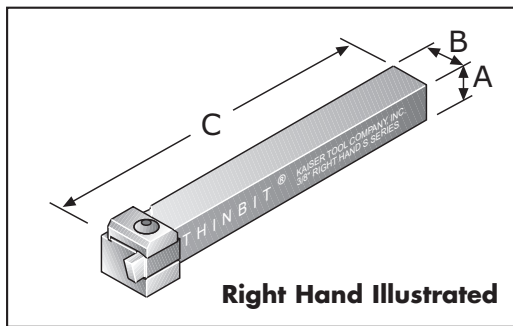

FLUSHTOP ORDERING INSTRUCTIONS

Select the **ORDER CODE** in the table below that represents your selection of shank orientation and dimensions.

EXAMPLE:

The **ORDER CODE** for a .375" shank, right hand flushtop tool for inserts beginning with 'L' is:
LFT38R

SPECIFICATIONS				ORDER CODE					
Shank Orientation	Shank Dimensions			Toolholder Package Includes Shank, Clamp and Hardware		Replacement Parts			
	'A'	'B'	'C'	For Inserts Beginning With (See pages 10-1, 10-2, 10-3 & 10-4)		Clamp	Screw	Wrench	Pin
			'S'	'L'					
Right Hand Use with right hand and centered inserts	.312"	.312"	4.840"	SFT56R	- - -	Clamp A	S5608	W1005	P0308
				- - -	LFT56R	Clamp C	S3808		
	.375"	.375"	4.840"	SFT38R	- - -	Clamp A	S5608		
				- - -	LFT38R	Clamp C	S3808		
	.500"	.500"	4.840"	SFT12R	LFT12R	Clamp C	S3808		
	.625"	.625"	4.840"	SFT58R	LFT58R	Clamp C	S3808		
Left Hand Use with left hand and centered inserts	.312"	.312"	4.840"	SFT56L	- - -	Clamp A	S5608		
				- - -	LFT56L	Clamp C	S3808		
	.375"	.375"	4.840"	SFT38L	- - -	Clamp A	S5608		
				- - -	LFT38L	Clamp C	S3808		
	.500"	.500"	4.840"	SFT12L	LFT12L	Clamp C	S3808		
	.625"	.625"	4.840"	SFT58L	LFT58L	Clamp C	S3808		

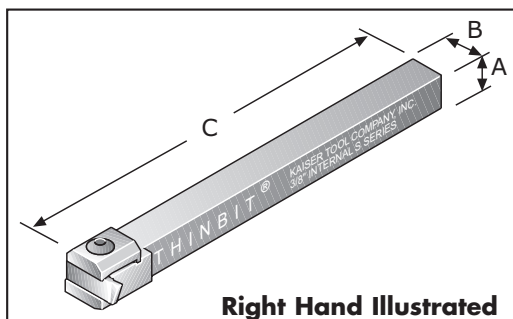

HARDINGE ORDERING INSTRUCTIONS

Select the **ORDER CODE** in the table below that represents your selection of shank orientation and dimensions.

EXAMPLE:

The **ORDER CODE** for a .375" shank, right hand tool for inserts beginning with 'L' is:
LHA38

SPECIFICATIONS					ORDER CODE					
Shank Orientation	Shank Dimensions			Minimum Bore Diameter with 'S' inserts; add .071" for 'L' inserts	Toolholder Package Includes Shank, Clamp and Hardware		Replacement Parts			
	'A'	'B'	'C'		For Inserts Beginning With (See pages 10-1, 10-2, 10-3 & 10-4)		Clamp	Screw	Wrench	Pin
				'S'	'L'					
Right Hand Use with left hand and centered inserts	.375"	.375"	4.840"	1.050"	SHA38	- - -	Clamp C	S3808	W1005	P0204
					- - -	LHA38				
	.500"	.500"	4.840"	1.290"	SHA12	LHA12				
Left Hand Use with right hand and centered inserts	.375"	.375"	4.840"	1.050"	SHA38	- - -				
					- - -	LHA38				
	.500"	.500"	4.840"	1.290"	SHA12	LHA12				

KAISER TOOL COMPANY, INC.

Phone: 888-THINBIT (888-844-6248) or (260) 484-3620
www.thinbit.com • Orders: orders@thinbit.com • Quotes: quotes@thinbit.com

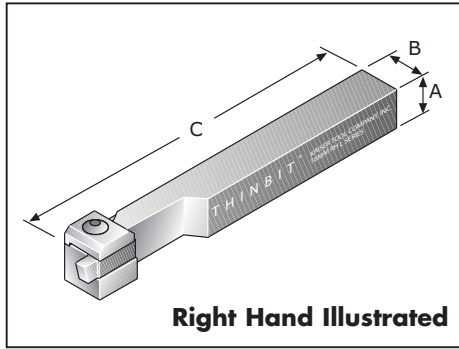

SWISS SCREW ORDERING INSTRUCTIONS

Select the **ORDER CODE** in the table below that represents your selection of shank orientation and dimensions.

EXAMPLE:

The **ORDER CODE** for a .500" shank, right hand tool for inserts beginning with 'L' is:

LSS12R

SWISS TOOLHOLDERS

SPECIFICATIONS				ORDER CODE							
Shank Orientation	Shank Dimensions			Toolholder Package Includes Shank, Clamp and Hardware		Replacement Parts					
	'A'	'B'	'C'	For Inserts Beginning With (See pages 10-1, 10-2, 10-3 & 10-4)		Clamp		Screw		Wrench	Pin
				'S'	'L'	'S'	'L'	'S'	'L'		
Right Hand Use with right hand and centered inserts	.375"	.375"	4.840"	SSS38R	---	A	--	S5608	---	W1005	P0305
	.500"	.500"		SSS12R	LSS12R	A	C	S5608	S3808		
	8mm	8mm		SSS08RM	---	A	--	S5608	---		
	10mm	10mm		SSS10RM	---	A	--	S5608	---		
	12mm	12mm		SSS12RM	LSS12RM	A	C	S5608	S3808		
	16mm	16mm		SSS16RM	LSS16RM	C	C	S3808	S3808		
Left Hand Use with left hand and centered inserts	.375"	.375"	4.840"	SSS38L	---	A	--	S5608	---	W1005	P0305
	.500"	.500"		SSS12L	LSS12L	A	C	S5608	S3808		
	8mm	8mm		SSS08LM	---	A	--	S5608	---		
	10mm	10mm		SSS10LM	---	A	--	S5608	---		
	12mm	12mm		SSS12LM	LSS12LM	A	C	S5608	S3808		
	16mm	16mm		SSS16LM	LSS16LM	C	C	S3808	S3808		

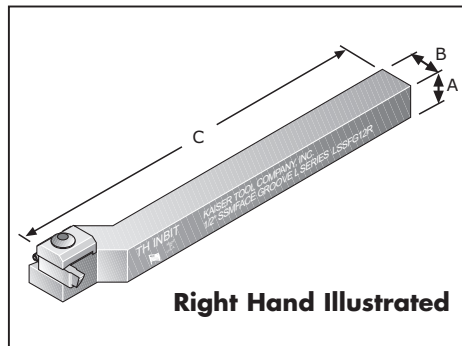

SWISS FACE ORDERING INSTRUCTIONS

Select the **ORDER CODE** in the table below that represents your selection of shank orientation and dimensions.

EXAMPLE:

The **ORDER CODE** for a .375" shank, right hand tool for inserts beginning with 'L' is:

LSSFG38R

SPECIFICATIONS				ORDER CODE							
Shank Orientation	Shank Dimensions			Toolholder Package Includes Shank, Clamp and Hardware		Replacement Parts					
	'A'	'B'	'C'	For Inserts Beginning With (See pages 10-1, 10-2, 10-3 & 10-4)		Clamp		Screw		Wrench	Pin
				'S'	'L'			'S'	'L'		
Right Hand Use with left hand and centered inserts for counter-clockwise rotation	.375"	.375"	4.840"	SSSFG38R	LSSFG38R	Clamp C		S3808	S3808	W1005	P0203
	.500"	.500"	4.840"	SSSFG12R	LSSFG12R			S3808			
	10mm	10mm	4.840"	SSSFG10RM	LSSFG10RM			S5452			
	12mm	12mm	4.840"	SSSFG12RM	LSSFG12RM			S5452			
	16mm	16mm	4.840"	SSSFG16RM	LSSFG16RM			S3808			

KAISER TOOL COMPANY, INC.

Phone: 888-THINBIT (888-844-6248) or (260) 484-3620
 www.thinbit.com • Orders: orders@thinbit.com • Quotes: quotes@thinbit.com

LITTLE :BT[®] REVERSIBLE TOOLHOLDER, STRAIGHT & 90°

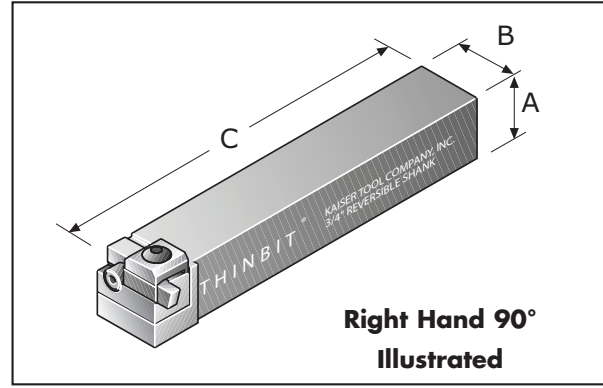
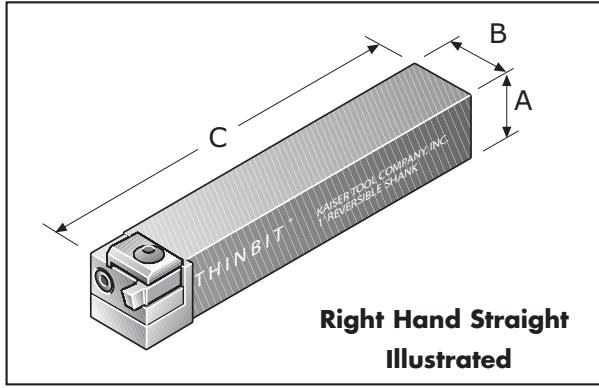

ORDERING INSTRUCTIONS

Select the **ORDER CODE** in the table below that represents your selection of shank orientation and dimensions.

EXAMPLE:

The **ORDER CODE** for a .750" shank and a 90° right hand tool for inserts beginning with 'L' is:
LRI3434R

SPECIFICATIONS				ORDER CODE									
Shank Orientation	Shank Dimensions			Toolholder Package Includes Shank, Head, Clamp and Hardware		Head Only Includes Clamp and Hardware For Inserts Beginning With		Replacement Parts					
	'A'	'B'	'C'	For Inserts Beginning With (See pages 10-1, 10-2, 10-3 & 10-4)		'S'	'L'	Head Screws	Head Wrenches	Head Pin	Shank	Clamp	Clamp Hardware
				'S'	'L'	'S'	'L'						
Straight Right Hand or Left Hand Use as right hand with right hand inserts; Use as left hand with left hand inserts; Use as either hand with centered inserts.	.375"	.750"	4.840"	SRE3438	LRE3438	SREH34	LREH34	1 each: S3808 S2808	1 each: W1005 W1009		RS3438	Clamp C	Screw: S3808 Wrench: W1005
	.500"			SRE3412	LRE3412						RS3412		
	.625"			SRE3458	LRE3458						RS3458		
	.750"			SRE3434	LRE3434						RS3434		
	.750"	1.000"	4.840"	SRE0134	LRE0134	SREH01	LREH01	1 each: S3812 S2808	1 each: W1005 W1009		RS0134		
	1.000"			SRE0101	LRE0101						RS0101		
	1.000"	1.250"	4.840"	SRE1401	LRE1401	SREH14	LREH14	1 each: S3816 S2808	1 each: W1005 W1009		RS1401		
1.250"			SRE1414	LRE1414						RS1414			
90° Right Hand Use with left hand and centered inserts	.375"	.750"	4.840"	SRI3438R	LRI3438R	SRIH34R	LRIH34R	1 each: S3808 S2812	1 each: W1005 W1009		RS3438	Clamp C	Screw: S3808 Wrench: W1005
	.500"			SRI3412R	LRI3412R						RS3412		
	.625"			SRI3458R	LRI3458R						RS3458		
	.750"			SRI3434R	LRI3434R						RS3434		
	.750"	1.000"	4.840"	SRI0134R	LRI0134R	SRIH01R	LRIH01R	1 each: S3812 S2812	1 each: W1005 W1009	P0305	RS0134		
	1.000"			SRI0101R	LRI0101R						RS0101		
90° Left Hand Use with right hand and centered inserts	.375"	.750"	4.840"	SRI3438L	LRI3438L	SRIH34L	LRIH34L	1 each: S3808 S2812	1 each: W1005 W1009		RS3438	Clamp C	Wrench: W1005
	.500"			SRI3412L	LRI3412L						RS3412		
	.625"			SRI3458L	LRI3458L						RS3458		
	.750"			SRI3434L	LRI3434L						RS3434		
	.750"	1.000"	4.840"	SRI0134L	LRI0134L	SRIH01L	LRIH01L	1 each: S3812 S2812	1 each: W1005 W1009	P0305	RS0134		
	1.000"			SRI0101L	LRI0101L						RS0101		

KAISER TOOL COMPANY, INC.

Phone: 888-THINBIT (888-844-6248) or (260) 484-3620
www.thinbit.com • Orders: orders@thinbit.com • Quotes: quotes@thinbit.com

LITTLE BIT® ROUND INTERNAL & REVERSIBLE TOOLHOLDERS

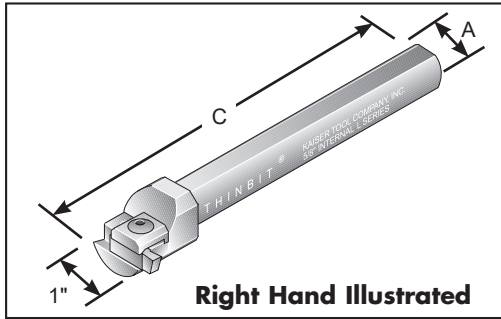

ROUND INTERNAL ORDERING INSTRUCTIONS

Select the **ORDER CODE** in the table below that represents your selection of shank orientation and dimensions.

EXAMPLE:

The **ORDER CODE** for a .625", 5.5" long round shank for inserts beginning with 'L' is:

LR5806

ROUND TOOLHOLDERS

SPECIFICATIONS				ORDER CODE					
Shank Orientation	Minimum Bore Diameter without pin	Shank Dimensions		Toolholder Package Includes Shank, Clamp and Hardware		Replacement Parts			
		'A'	'C'	For Inserts Beginning With (See pages 10-1, 10-2, 10-3 & 10-4)		Clamp	Screw	Wrench	Pin
				'S'	'L'				
Right Hand or Left Hand Use as right hand with left hand inserts; Use as left hand with right hand inserts; Use as either hand with centered inserts.	1.125"	.500"	5.500"	SR1206	---	Clamp C	S3808	W1005	P0305
		.625"		SR5806	---				
		.750"		SR3406	---				
		1.000"		SR0106	---				
			11.875"	SR0112	---				
	1.187" (1.250" for insert beginning with 'LGT')	.500"	5.500"	---	LR1206				
		.625"		---	LR5806				
		.750"		---	LR3406				
1.000"		---		LR0106					
		11.875"	---	LR0112					

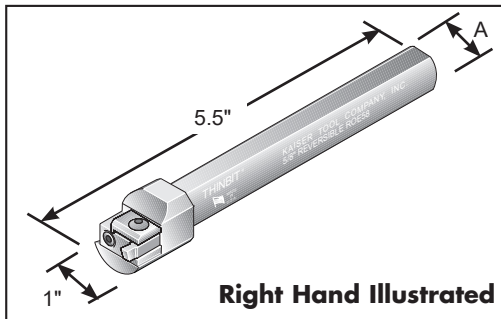

ROUND REVERSIBLE ORDERING INSTRUCTIONS

Select the **ORDER CODE** in the table below that represents your selection of shank dimensions.

EXAMPLE:

The **ORDER CODE** for a .625" round shank for inserts beginning with 'L' is:

LROE58

SPECIFICATIONS			ORDER CODE							
Shank Orientation	Shank Dimensions 'A'	Toolholder Package Includes Shank, Head, Clamp and Hardware		Replacement Parts						
		For Inserts Beginning With (See pages 10-1, 10-2, 10-3 & 10-4)		Head Only Includes Clamp and Hardware For Inserts Beginning With		Head Screws	Head Wrenches	Shank	Clamp	Clamp Hardware
		'S'	'L'	'S'	'L'					
Right Hand or Left Hand Use as right hand with right hand inserts; Use as left hand with left hand inserts; Use as either hand with centered inserts.	.500"	SROE12	LROE12	SROEH	LROEH	1 each: S5806 S2810	1 each: W1006 W1009	RROE12	Clamp C	Screw: S3808 Wrench: W1005
	.625"	SROE58	LROE58					RROE58		
	.750"	SROE34	LROE34					RROE34		
	1.000"	SROE01	LROE01					RROE01		

KAISER TOOL COMPANY, INC.

Phone: 888-THINBIT (888-844-6248) or (260) 484-3620
 www.thinbit.com • Orders: orders@thinbit.com • Quotes: quotes@thinbit.com

KAISER TOOL COMPANY, INC.

Phone: 888-THINBIT (888-844-6248) or (260) 484-3620
www.thinbit.com • Orders: orders@thinbit.com • Quotes: quotes@thinbit.com

INTRODUCING

MILL A GROOVE[®]

THINBIT[®], by
Kaiser Tool Company,
presents the **Mill A Groove[®]**
line for trepanning on a CNC
or conventional milling
machine using a boring holder.



MILLING

Mill A Groove[®] enables machining groove diameters that are concentric to the spindle rotation and not the table movement and eliminates secondary lathe operations for face grooving.

The insert does not rotate about its own center, so the groove can be symmetrical or asymmetrical. One insert can make convex and concave radius grooves, chamfered edges, angles and special profiles.

KAISER TOOL COMPANY, INC.

Phone: 888-THINBIT (888-844-6248) or (260) 484-3620
www.thinbit.com • Orders: orders@thinbit.com • Quotes: quotes@thinbit.com

11-1

THINBIT[®] MILL A GROOVE[®]

MILLING

PRODUCT INFORMATION

- Designed for trepanning on CNC machines.
- Enables machining groove diameters that are concentric to the spindle rotation, not the table movement.
- Eliminates secondary lathe operations for face grooving.
- Groove can be symmetrical or asymmetrical.
- One insert can make convex and concave radius grooves, chamfered edges, angles and special profiles.

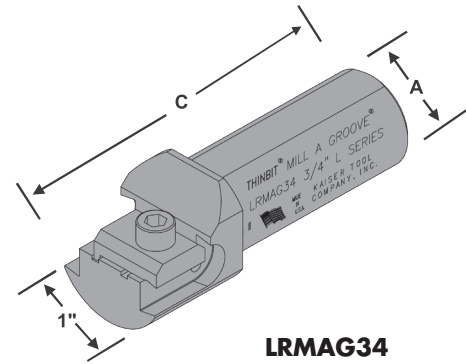

LRMAG34

INSERT SELECTIONS

FACE GROOVING

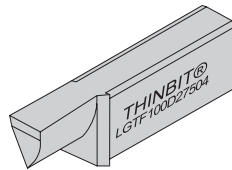

PG 2-9

TOOLHOLDER

Due to the potential complexity of configuring these toolholders, we recommend calling for assistance.

For additional Toolholder options
See page 7-8

TOOLHOLDER

MILL A GROOVE[®] toolholders are designed to work in combination with boring heads and are available in common sizes with straight and 90° orientations.

ORDERING INSTRUCTIONS

Select the **ORDER CODE** in the table below that represents your selection of shank dimensions.

EXAMPLE:

The **ORDER CODE** for a 1/2" round shank for inserts beginning with 'L' is:

LRMAG12

TECHNICAL SECTIONS	SPEEDS AND FEEDS	FORMULA	TROUBLESHOOTING
	PG 9-12 Use Inches Per Revolution for the chip load to calculate the Inches Per Minute on milling machines.	$RPM = \frac{SFM \times 12}{\pi \times DIAMETER}$ $RPM \times \text{Chip Load} = \text{Inches per Minute}$	PG 9-7

Shank Orientation	Shank Dimensions "A"	Toolholder Package (Includes Shank, head, clamp and hardware)	Overall Length "C"	Clamp	Clamp Hardware
Right Hand or Left Hand	.500" Ø X 1.50" long	LRMAG12	2.35"	Clamp C	Screw: S2808 Wrench: W1009 Pin: P0305
	.625" Ø X 1.63" long	LRMAG58	2.48"		
Use as right hand with right hand inserts	.750" Ø X 1.63" long	LRMAG34	2.48"		
	.787" Ø X 1.63" long	LRMAG20M	2.48"		
Use as left hand with left hand inserts	.984" Ø X 1.92" long	LRMAG25M	2.77"		
Use as either hand with centered inserts	1.00" Ø X 1.92" long	LRMAG01	2.77"		

KAISER TOOL COMPANY, INC.

Phone: 888-THINBIT (888-844-6248) or (260) 484-3620
www.thinbit.com • Orders: orders@thinbit.com • Quotes: quotes@thinbit.com

THINBIT®

- **FASTER**
- **MORE OPTIONS**
- **LESS EXPENSIVE**
- **LASTS LONGER**

**MILL A
GROOVE®**

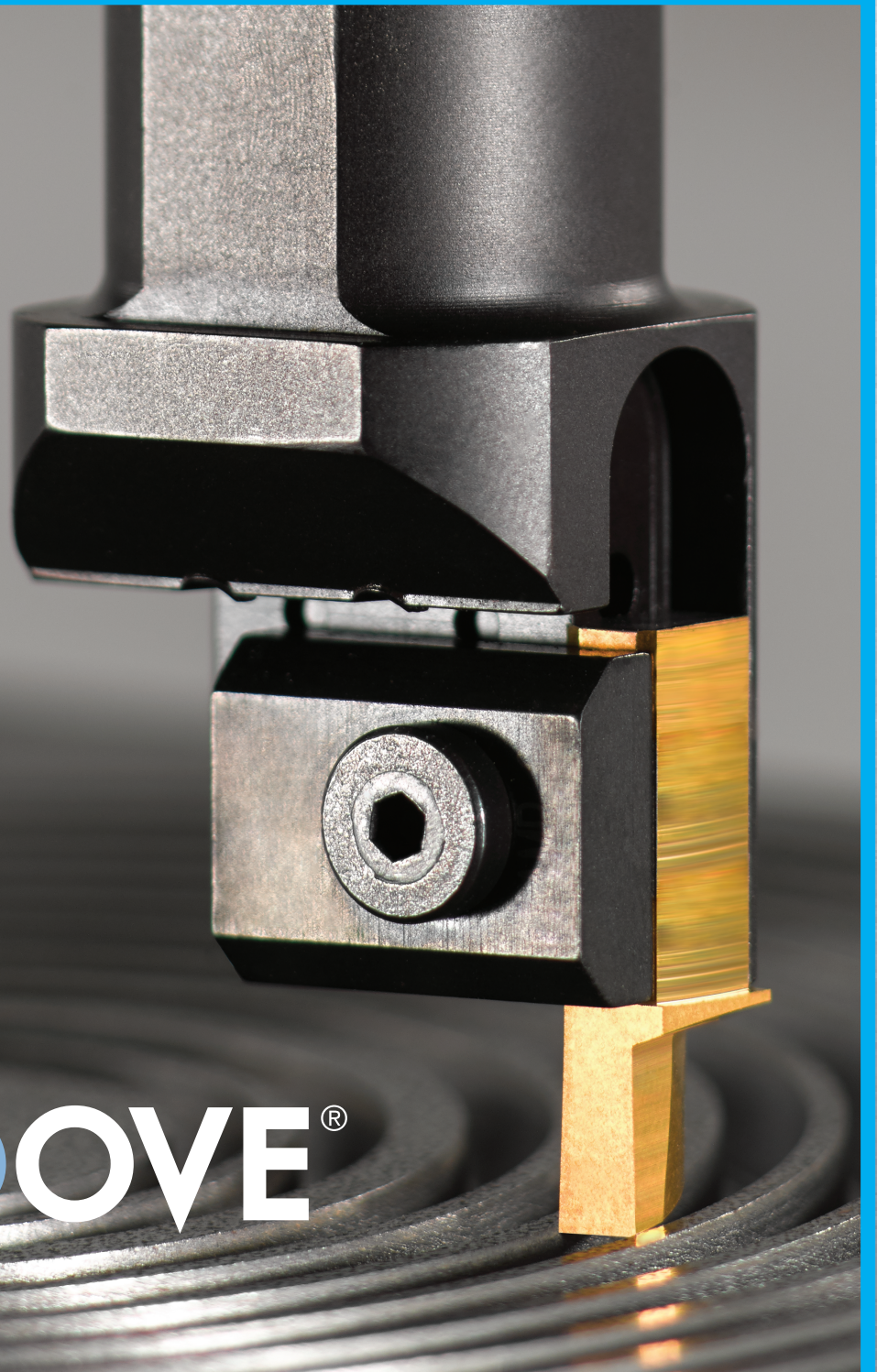



MINI-BORE®

SECTION 3

CD, TD, TP AND TRIGON STYLE INDEXABLE BORING BARS



GROOVE 'N TURN®

WHAT CAN YOU DO WITH A SINGLE INSERT?

DESIGN-A-GROOVE®

We Can Do That!®

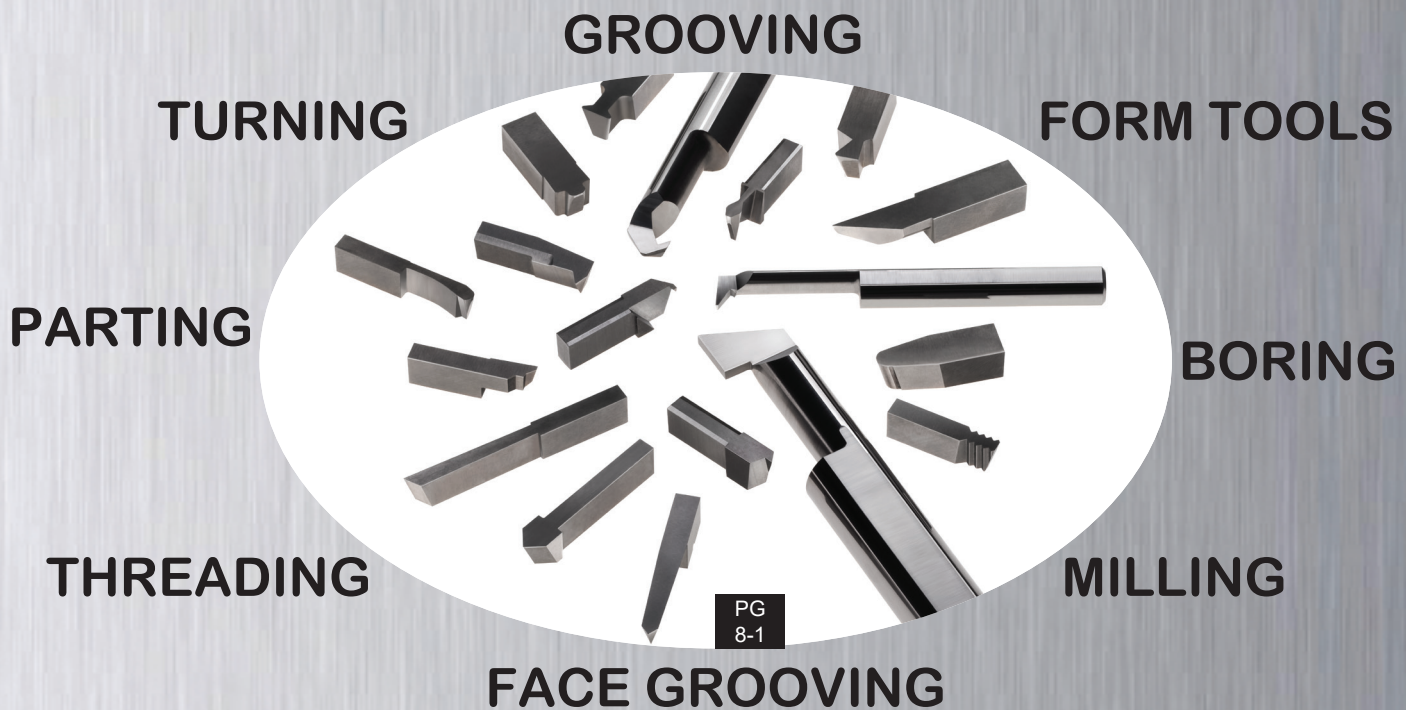

THINBIT® is an industry leader at designing and manufacturing custom tooling.

E-mail your application to quotes@thinbit.com.

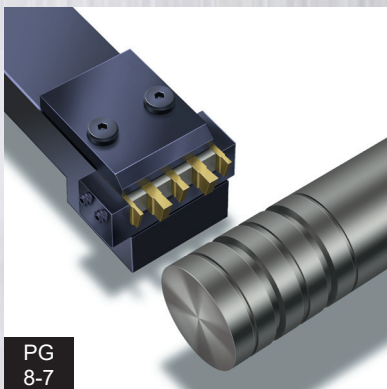

FORM-A-GROOVE® tools consist of simple grooves or complex combinations of grooves, arcs, angles, convex and concave radii, as well as special thread forms.



**MADE IN[®]
THE USA?
DAMN RIGHT.**

**EXTERNAL
GROOVING**

Section 1

BORING

Section 3

**INTERNAL
GROOVING**

Section 1

**INTERNAL
FACE GROOVING**

Section 2

CUSTOM TOOLING

Section 8

**EXTERNAL
FACE GROOVING**

Section 2

**FORM
TOOLING**

Page 8 - 7

THREADING

Section 4

MILLING

Section 11

PARTING

Section 5

US Patent Nos.: 6,688,816; 6,824,333; 5,638,728; 6,722,825; 6,974,282

Follow us on:



THINBIT[®].COM

Kaiser Tool Company, Inc. | 3620 Centennial Dr., Ft. Wayne, IN 46808
888-THINBIT | thinbit@kaisertool.com